

PHYSICS

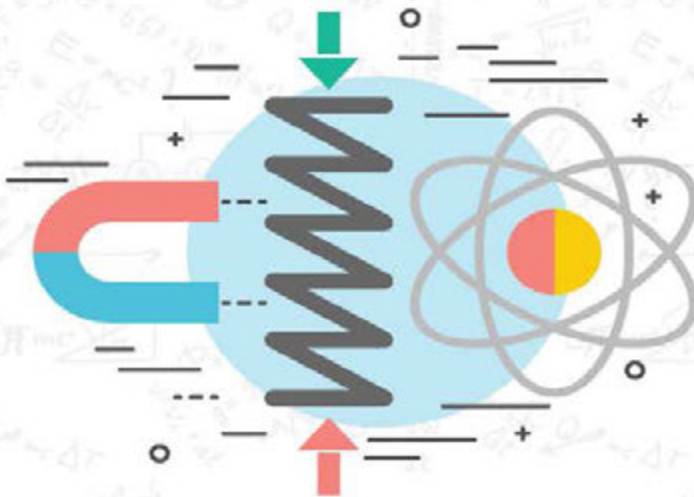

ҚОСТІЛДІ ОҚУЛЫҚ

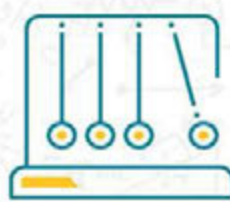

8



АСТАНА
К И Т А П

Алтынбек Карабатыров
Айбек Байешов
Есбол Дуйсеев
Нурсултан Шокобалинов
Нурлыбек Ташев

Қазақстан Республикасының
Білім және ғылым министрлігі ұсынған

PHYSICS

Grade 8

БІРІНШІ БАСЫЛЫМ

АСТАНА
К І Т А П

Астана 2017

ӘОЖ 373.167.1(075.3)
КБЖ 22.3 я 72
Р 56

Р 56 Қарабатыров А.
PHYSICS, Grade 8: Қостілді оқулық/Алтынбек Қарабатыров,
Айбек Байешов, Есбол Дүйсеев, Нурсултан Шокобалинов, Нурлыбек Ташев
– Алматы: Астана-кітап, 2017. - 160 б.
ISBN 978-601-7415-75-4

ӘОЖ 373.167.1(075.3)
КБЖ 22.3 я 72

ISBN 978-601-7415-75-4

© Астана-кітап, 2017
Барлық құқықтары қорғалған
Басылымның мүліктік құқықтары
"Астана-кітап" баспасына тиесілі

CONTENTS

[PREFACE](#)

[CHAPTER 1](#)

HEAT PHENOMENA

[1.1 Motion of atoms and molecules](#)

[1.2 Temperature and internal energy.](#)

[1.3 Heat transfer](#)

[1.4 Application of heat transfer](#)

[1.5 Specific heat capacity.](#)

[1.6 Heat of combustion](#)

[1.7 Heat exchange](#)

[LAB WORK 1](#)

[Summary.](#)

[Problems](#)

[CHAPTER 2](#)

STATES OF MATTER

[2.1 Melting and freezing](#)

[2.2 Evaporation and condensation](#)

[2.3 Graphical analysis](#)

[2.4 Humidity](#)

[LAB WORK 2](#)

[Summary](#)

[Problems](#)

CHAPTER 3

THERMODYNAMICS

[3.1 First law of thermodynamics](#)

[3.2 Second law of thermodynamics](#)

[3.3 Heat engines](#)

[3.4 Efficiency of heat engine](#)

[3.5 Ecology and energy](#)

[Summary](#)

[Problems](#)

CHAPTER 4

ELECTROSTATICS

[4.1 Electric charge](#)

[4.2 Charging methods](#)

[4.3 Conservation of charge. Coulomb's law](#)

[4.4 Electric field. Part 1](#)

[4.5 Electric field. Part 2](#)

[4.6 Electric potential. Potential difference](#)

[4.7 Capacitance and Capacitors](#)

[Summary](#)

[Problems](#)

CHAPTER 5

ELECTRIC CURRENT

[5.1 Electric current](#)

[5.2 Electric circuit. Voltage](#)

[5.3 Electrical resistance](#)

[5.4 Resistivity](#)

[5.5 Parallel and series connections of resistors](#)

[5.6 Electrical energy and power](#)

[5.7 Short circuit](#)

[5.8 Electric current in liquids and gases](#)

[LAB WORK 3](#)

[LAB WORK 4](#)

[LAB WORK 5](#)

[LAB WORK 6](#)

[LAB WORK 7](#)

[Summary](#)

[Problems](#)

CHAPTER 6

ELECTROMAGNETISM

[6.1 MAGNETIC FIELD](#)

[6.2 Magnetic field in nature](#)

[6.3 Electric motors](#)

[6.4 Electricity production](#)

[LAB WORK 8](#)

[LAB WORK 9](#)

[Summary](#)

[Problems](#)

CHAPTER 7

OPTICS

[7.1 Lunar and solar eclipse](#)

[7.2 Reflection](#)

[7.3 Concave mirror](#)

[7.4 Convex mirror](#)

[7.5 Refraction](#)

[7.6 Total internal reflection](#)

[7.7 Converging lens](#)

[7.8 Diverging lens](#)

[7.9 Human eye and optical devices](#)

[LAB WORK 10](#)

[LAB WORK 11](#)

[Summary](#)

[Problems](#)

[Glossary](#)

[Answers](#)

[References](#)

АЛҒЫ СӨЗ

Жаратылыстану ғылымдары қызықты, әрі тартымды пәндер. Бұл оқулық сізге ғылым әлемінің барша сұлулығы мен жасырын құпияларын паш етуге және сіздің шынайы зерттеушілік қабілетіңіздің ашылуына жол сілтейді. Оқулықтың басты мақсаты «Ғылым не үшін қажет және алған білімді өміріміздің қай саласында қолданамыз?» деген тәрізді күрделі сұрақтарға жауап іздейді.

Оқулықтың алғашқы беттерінен-ақ сіз өзіңізге үйреншікті болған теория мен түрлі формулаларды қамтитын қарапайым мәтіндерден құралған басқа оқулықтардан өзгеше екендігін аңғара түсесіз. Әрбір тарау берілген тақырыптардың аясын қамтитын қызықты деректер мен ақпараттардан, жеке және топтық ұжымда орындауға арналған тапсырмалар жинағынан тұрады. Сондай-ақ, сіз түрлі тәжірибелік жұмыстар мен зерттеулерді жасауға, түрлі ақпараттар мен деректерді іздеп тауып, оларға сараптама жасау арқылы өзіндік дербес жаңалықтарыңызды ашуға машықтанасыз.

Берілген оқулықтың басқалардан ерекшелігі – оның көптілділігінде. Алғашқы беттерден-ақ, сіз материалдардың ана тілінен бөлек, халықаралық ғылым тілі – ағылшын тілінде берілгенін байқайсыз. Оқулықтың әрбір шебінен сіз негізгі терминдердің аудармаларын үш тілде: қазақ, орыс және ағылшын тілдерінде таба аласыз. Біртіндеп ағылшын тіліндегі сөздер мен сөйлемдер саны артып, оқулықтың соңғы жағындағы материалдардың басым бөлігі ағылшын тілінде берілетін болады.

Бұл арқылы сіз ағылшын тіліңізді жетілдіріп қана қоймай, ғылым әлеміндегі шексіз жаңалықтар мен жетістіктерге

қарай қадам басасыз.

Оқулықтың құрылымымен мұқият түрде танысыңыз.
Қазіргі таңдағы оқулықтар жалғыз ақпарат көзі болып табылмайтындығын есте сақтаңыз.

Сізге ХХІ ғасырдың дағдыларын, яғни сыни тұрғыдан ойлау, шығармашылық қабілетті дамыту, қиялдау, топпен жұмыс жасау, сандық сауаттылық және т.б. қабілеттеріңізді дамытуға бағытталған кең көлемдегі тапсырмаларға бейімделіп, үйренуге тура келеді.

Егер Сізде оқулықтың мазмұны мен құрылымы бойынша туындаған сұрақтарыңыз бен ұсыныстарыңыз бар болса, төмендегі байланыс құралдары арқылы бізге жолдауларыңызды сұраймыз:

- электронды почта:

info@astanakitap.kz

- telegram қосымшасы:

[@astanakitap](https://www.instagram.com/astanakitap)

Құрметпен,

“Астана-кітап” авторлық ұжымы

CHAPTER 1

HEAT PHENOMENA

1.1 MOTION OF ATOMS AND MOLECULES

1.2 TEMPERATURE AND INTERNAL ENERGY

1.3 HEAT TRANSFER

1.4 APPLICATION OF HEAT TRANSFER

1.5 SPECIFIC HEAT CAPACITY

1.6 HEAT OF COMBUSTION

1.7 HEAT EXCHANGE

LAB WORK 1

SUMMARY

PROBLEMS



1.1 MOTION OF ATOMS AND MOLECULES

YOU WILL:

- describe experimental proofs and show examples of Molecular Kinetic Theory.

QUESTION:

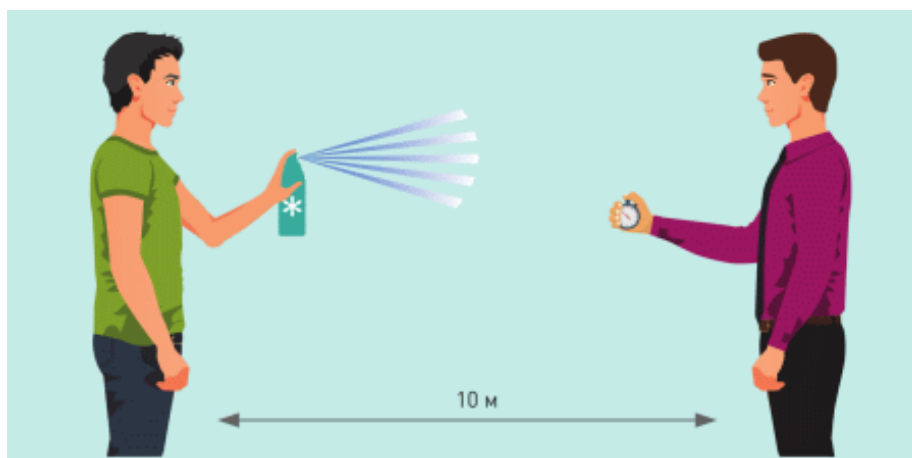

Azamat uses air freshener, Ruslan stands 10 meters away from Azamat and measures time when he starts to feel the smell.

1. What may the measured time be?
2. The speed of freshener molecules is about 600 m/s. Why does the smell reach Ruslan slowly?

БРОУНДЫҚ ҚОЗҒАЛЫС

1827 жылы ботаник Роберт Броун тозақ түйіршіктерін суға салып, олардың қозғалысын микроскоп арқылы зерттеген. Түйіршіктердің тербелісін көріп, су молекулалары қозғалатынын анықтайды. Су молекулалары ретсіз қозғалғандықтан, түйіршіктерге соқтығысып, ретсіз тербелістерді тудырады, Figure 1. Кейінен осы тербелістер "броундық қозғалыс" деп аталатын болды.

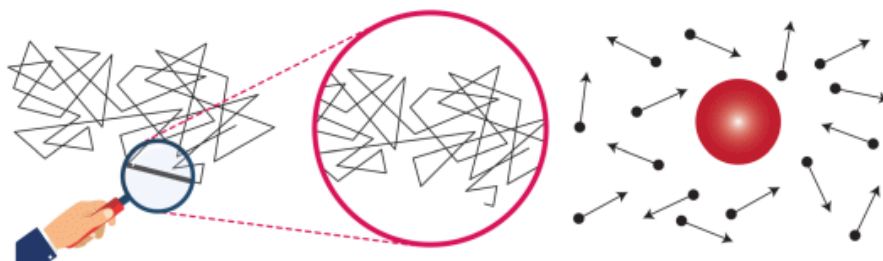

Figure 1. Water molecules hit pollen. This causes Brownian motion of pollen particle.

ДИФФУЗИЯ

Ал, енді мына мысалға назар аударайық. Судың ішіне сия тамызсақ, сия су ішінде тарала бастайды, Figure 2. Себебі, су молекулалары әрдайым қозғалыста болып, сия молекулаларымен соқтығысады.



Figure 2

Бұндай құбылысты, яғни екі заттың молекулаларының бір-бірімен араласып, біріне-бірі өтуі құбылысын диффузия деп атаймыз. Диффузия құбылысы газдарда да орын алуы мүмкін. Мысал ретінде ауа сергіткіші иісінің ауадағы таралуын алуға болады.

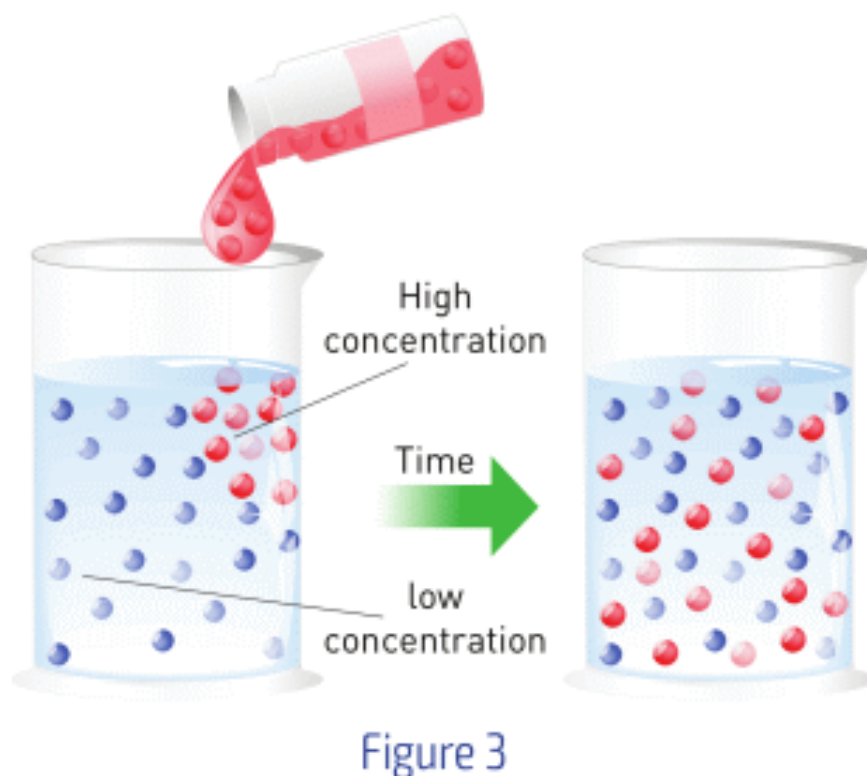

Figure 3

Диффузияның басты 2 қасиеті:

1. Молекулалар жоғары концентрациядан аз мөлшерлі концентрация бағытында қозғалады,
2. Температура жоғарлаған сайын диффузия жылдамдығы да артады.

МОЛЕКУЛАЛЫҚ-КИНЕТИКАЛЫҚ ТЕОРИЯ

Айналамыздағы барлық денелер өте кіші бөлшектерден құралады.

Оларды атомдар мен молекулалар деп атаймыз. Осы бөлшектердің қозғалысын- молекулалы-кинетикалық теория зерттейді. Бөлшектердің қозғалысы үздіксіз болғаны үшін "кинетикалық" сөзі қолданылады.

Бөлшектердің қозғалысы температурамен тікелей байланысты.

Бұл жылулық қозғалыс деп аталады. Температура жоғарлаған сайын бөлшектердің жылдамдығы да артады.

Молекулалы-кинетикалық теорияның басты үш қағидасы:

1. Барлық денелер кішкентай бөлшектерден құралады.
2. Бөлшектер ретсіз және үздіксіз қозғалады.
3. Бөлшектер өзара әсерлеседі.

Жылу беру, броундық қозғалыс және диффузия молекулалы-кинетикалық теорияның тәжірибелік дәлелі болып табылады.

EXAMPLE

Қайсысы диффузияға жатады?

1. Ыстық судың ішіндегі шай қалташасы.
2. Шайдың ішіндегі қант.
3. Бөлмедегі шамның жарқырауы.
4. Су ішіндегі тиын.
5. Бір қатардағы адамдар.

Answer: 1,2

FACT

Perfume stores have coffee beans. It is because trying many perfumes dulls your smelling ability. However, coffee beans help to refresh smelling ability.

ACTIVITY

1. How do molecules of meal reach your nose? Which meal will produce a stronger smell, hot or cold? Why?
2. Draw a path of air freshener molecule that reaches Ruslan first. Use the answers that you have given before.

ART TIME

Make a model of a water molecule and explain it to your parents, teachers and friends.

LITERACY

1. Броундық қозғалыста тозаңдар не себепті қозғалады? Бөлшектер ыстық суда және суық суда қалай қозғалады?
2. Тұз суық суға қарағанда ыстық суда тезірек ериді. Не себепті?
3. Суық ауада иіс неге нашар сезіледі?
4. Гелий шарлары уақыт өткен сайын неге кішірейеді?

IT-LINK

Go to phet.colorado.edu and search Brownian motion.

TERMINOLOGY

- invisible - көрінбейтін / невидимый
- random - кездейсоқ / случайный
- pollen grain - тозаң / пыльца
- consist of - құралады / состоять из
- constant - тұрақты / постоянный
- to interact - әсерлесу / взаимодействовать

1.2 TEMPERATURE AND INTERNAL ENERGY

YOU WILL:

- - describe the usage of thermal expansion in temperature measurement;
- - use different temperature scales (Kelvin, Celsius);
- - describe ways of changing of internal energy.

QUESTION:

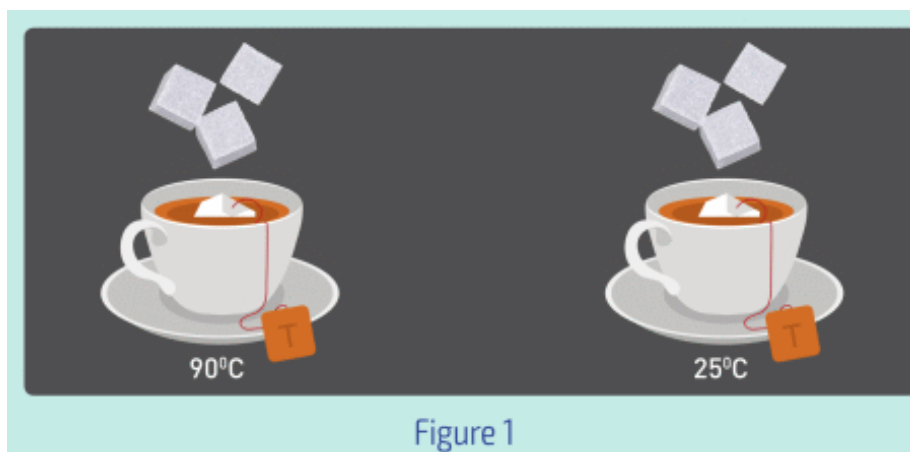

Alikhan conducts an experiment. He puts sugar cubes into tea but does NOT mix them. After several minutes, he looks at sugar cubes (Figure 1).

Discuss the following questions.

- a) How do the shapes of sugar cubes change?
- b) Why do the shapes change?

c) In which cup does the cubes' shape change faster?

ТЕМПЕРАТУРА

Затты қыздырған жағдайда оның температурасы жоғарлайды.

Бұл молекулалардың жылдамдықтарын арттырады. Ал жылдамдық артқанда молекулалардың арақашықтығы артып, қатты дененің көлемі ұлғаяды, Figure 2.

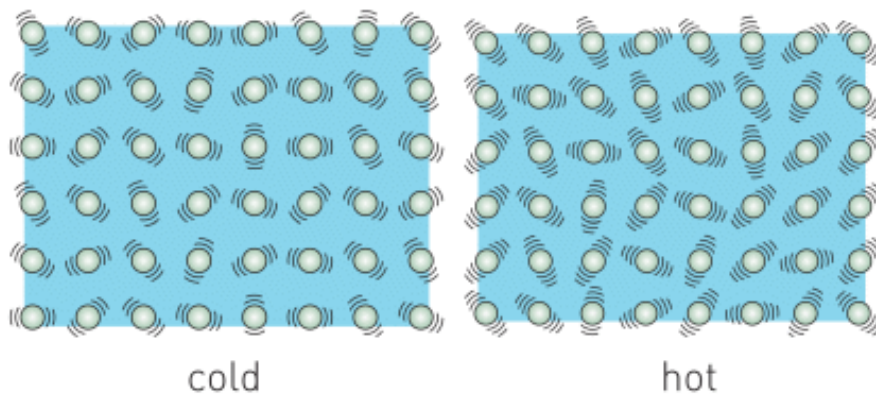

Figure 2

Дене температурасын өлшеуге арналған құрал термометр деп аталады.

Кез келген сұйықты қыздырған кезде оның көлемі ұлғаяды. Кейбір сұйықтарда ұлғаю көбірек байқалғандықтан, оларды қолданып термометр жасауға болады. Мысалы, спирт пен сынап. Сынаптың түсі сұр болғандықтан, оның термометр бағанасындағы ұлғаюы көзге жақсы көрінеді. Ал, спирт түссіз сұйық болғандықтан, көзге анық көрінуі үшін қызыл түске боялады, Figure 3.

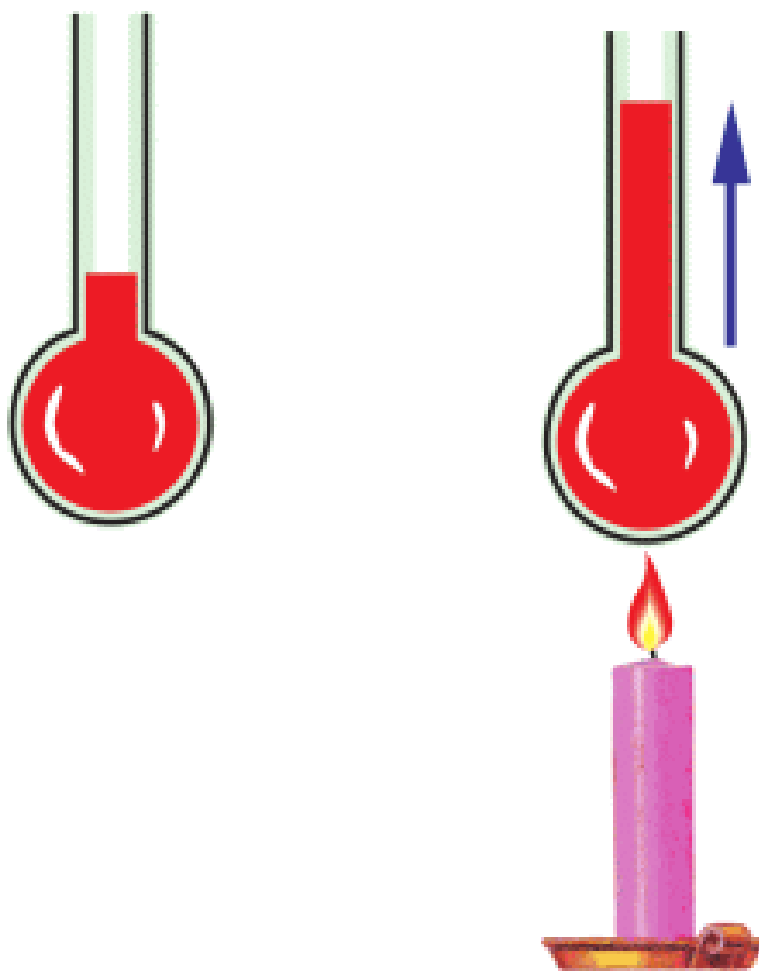

Figure 3

Температура Цельсий шкаласымен ($^{\circ}\text{C}$) өлшенеді. Бұл шкала судың қату және қайнау температураларына негізделді.

Су Цельсий шкаласы бойынша 0°C қатып, 100°C қайнайды. Осы екі температура

аралығын бірдей 100 бөлікке бөлсек, әр бөлік 1 градус Цельсийге сәйкес келеді, Figure 4.

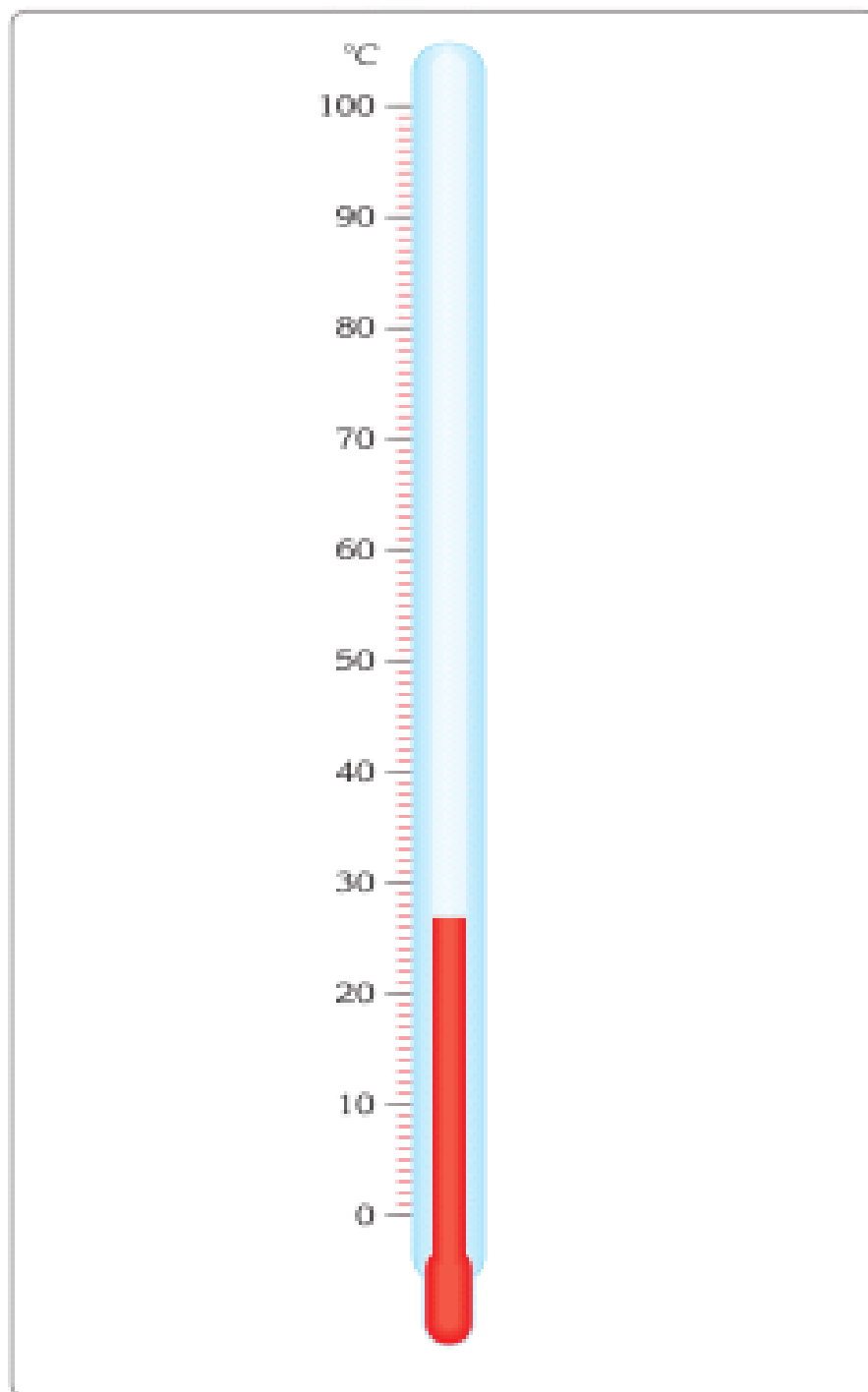

Figure 4

Әлемдегі ең төмен температура -273°C . Оны "абсолют нөлі" деп атайды. Бұл Кельвин шкаласының қолданылуының негізгі себебі.

Кельвин шкаласы тек ғылыми салаларда ғана қолданылады.

$$\text{Kelvin} = 273 + \text{Celsius}$$
$$T(\text{K}) = 273 + T(^{\circ}\text{C})$$

ІШКІ ЭНЕРГИЯ

Температура атомдар және молекулалардың жылдамдығына тікелей байланысты. Демек, температура атомдар мен молекулалардың кинетикалық энергиясына тәуелді деп айта аламыз. Атомдар мен молекулалардың кинетикалық энергияларының қосындысы заттың ішкі энергиясына тең:

INTERNAL ENERGY

=

KINETIC ENERGY OF
MOLECULES

DISCUSSION

а) Цельсий шкаласында судың қату және қайнау нүктесі не үшін қолданылады?

б) Температура төмендегенде атом және молекулалардың жылдамдықтары төмендейді. Ең төмен температурада атомдар мен молекулалардың қозғалысы қандай болуы мүмкін?

DISCUSSION

This boy shakes a bottle of water. Does the speed of water molecules increase or decrease? How does it affect average kinetic energy? Does the temperature increase or decrease? Why? How does internal energy of water in the bottle change?

ACTIVITY

Centre of the Sun	
Surface of the Sun	
Light bulb filament	
Fire	
Human body	
Freezing point of water	
Freezing point of mercury	
Absolute zero	

Келтірілген температураларды кестеге толтырып, сәйкестендіріңіз.

2800°C, 900°C, -273°C, 15000000°C, 36.6°C, -37°C, 6000°C, 0°C.

EXAMPLE

Ауа температурасы 25°C болса, Кельвин шкаласы бойынша температура неге тең?

Формула: $T(K) = 273 + T(^{\circ}C)$

Шешімі: $K = 25 + 273 = 298 K$

Жауабы: Температура 298 К.

FACT



The forehead thermometer has a heat-sensitive strip inside. The heat-sensitive strip can change its colour. The colour on the strip indicates the temperature.

LITERACY

1. 50°C температурадағы су адамға неге ыстық сезіледі? Ал, 10°C температурадағы су адамға неге суық сезіледі? Ыстық немесе суықтың сезілуі біздің денеміздің температурасына байланысты ма?
2. Қайсысы мұзды көбірек ерітеді: температурасы 70°C , массасы 100 г су немесе температурасы 20°C , массасы 100 г су ма? Не себепті?
3. 600 K температурадағы 1 кг темірдің ішкі энергиясы 300 K температурадағы 1 кг темірден екі есе артық. Не себепті? 300 K температурадағы 2 кг темірдің ішкі энергиясы, 300 K температурадағы 1 кг темірге қарағанда екі есе көп. Не үшін?

4. Кестені толтырыңыз.

300 K °C
36.6°C K
6000°C K
15 K °C

ART TIME

"Температура"-ның суретін салыңыз және де өзіңіздің ата-анаңызға, мұғалімдеріңізге және достарыңызға көрсетіңіз.

TERMINOLOGY

- to increase – көбею / увеличение
- to decrease – азаю / уменьшение
- to expand – ұлғаю / расширение
- mercury – сынап / ртуть
- colourless – түссіз / бесцветный
- scale – шкала / шкала
- bulb filament – вольфрам
- жібі / нить накаливания

1.3 HEAT TRANSFER

YOU WILL:

- - compare different types heat transfer.

QUESTION

Look at pictures and answer the question. Explain your answers.

Why do fire-fighters wear shiny suits?



Which of the palms feel more heat? Why?

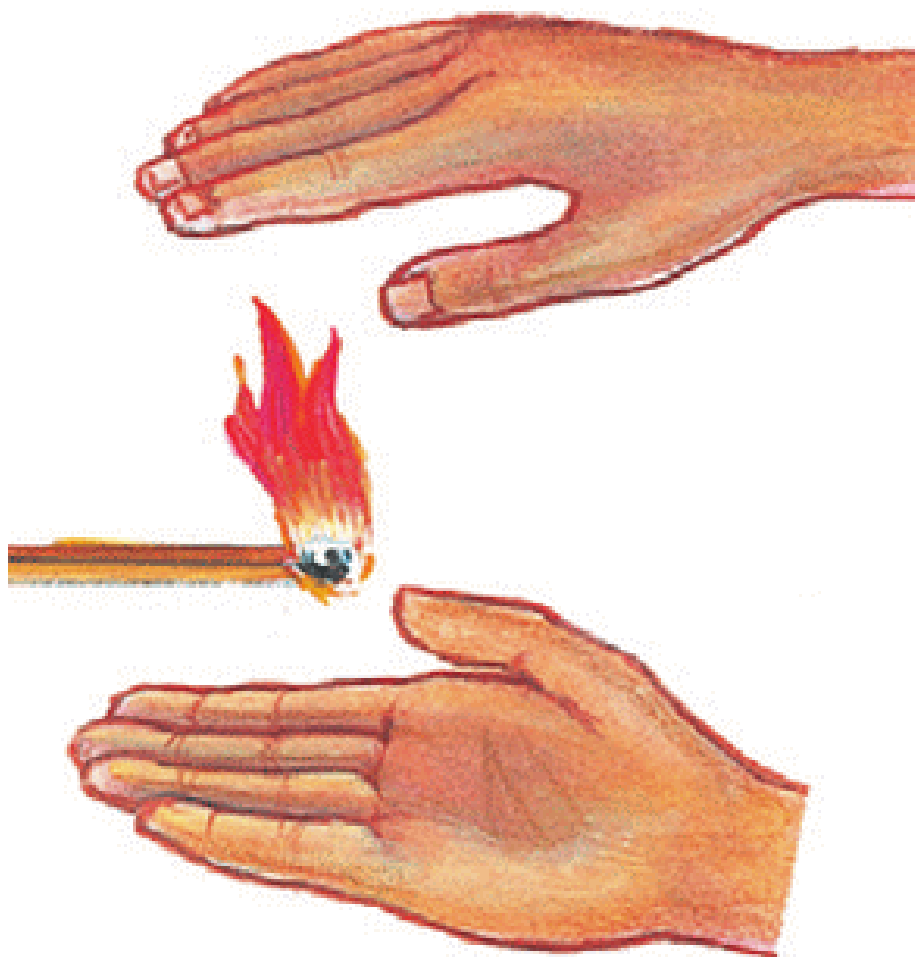

Which spoon is better to use? Why?



ЖЫЛУ ТАСЫМАЛЫ

Жылу бір жерден басқа жерге тасылмалдана алады. Жылу тасымалының үш түрі бар: жылуөткізгіштік, конвекция және сәуле шығару. Суреттерде мысалдар көрсетілген, Figure 1.

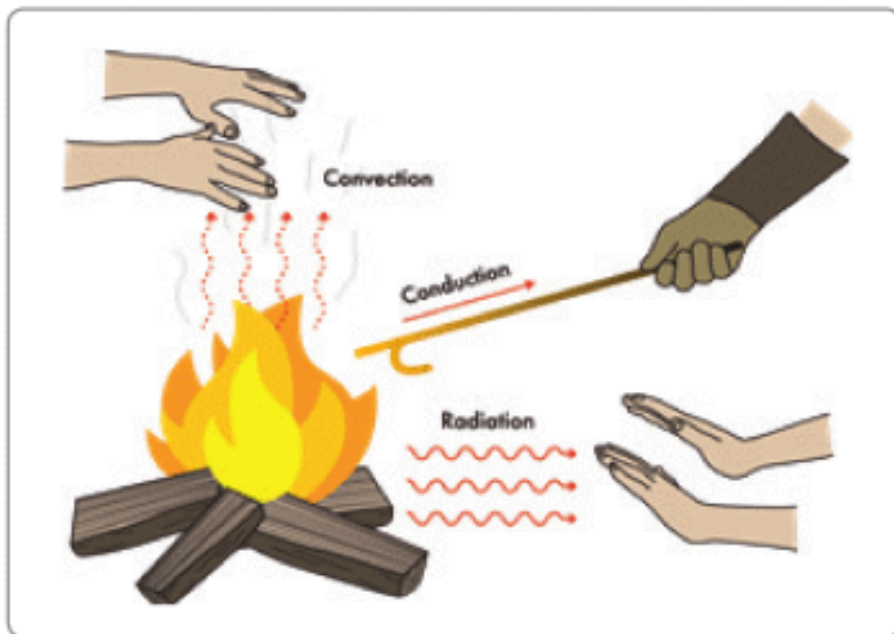

Figure 1

ЖЫЛУӨТКІЗГІШТІК ДЕГЕН НЕ?

Жылуөткізгіштік деп қатты денелердегі жылу энергиясының тасымалын атаймыз. Жылу энергиясы қатты дененің ыстық бөлшектері суық бөлшектеріне соқтығысуы арқылы беріледі, Figure 2.

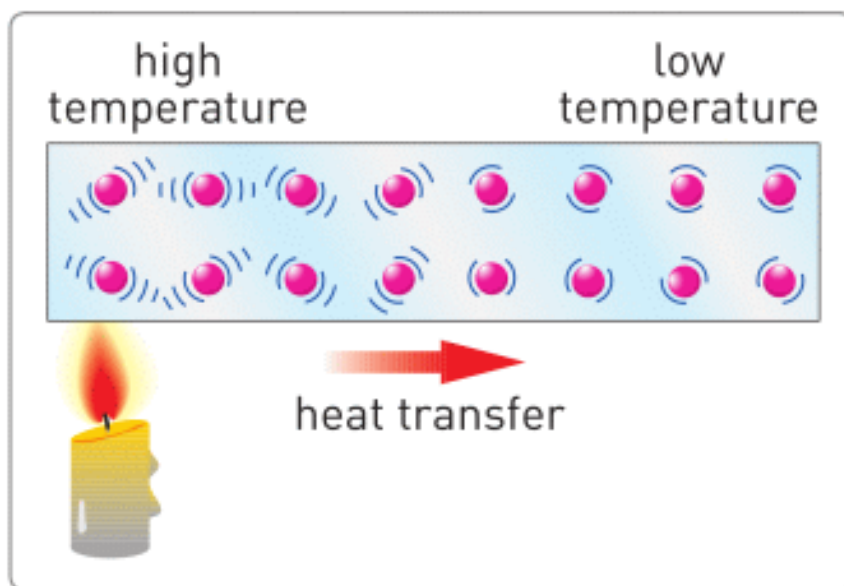

Figure 2

Металдардың жылуөткізгіштігі жоғары болады, сондықтан олар жылу энергиясын жақсы тасымалдайды. Мысалы, темір, мыс, алюминий және күміс. Бұлар жылуөткізгіш материалдар деп аталады.

Ал, ағаш, әйнек, қағаз, ауа, пластик сияқты заттардың жылуөткізгіштігі төмен, өйткені олар жылуды нашар тасымалдайды.

Бұларды оқшаулағыш материалдар деп атаймыз. Оқшаулағыш материалдарды күнделікті өмірде әртүрлі мақсаттарда қолданамыз.

Мысалы, қолымыз күймеуі үшін шәйнектің тұтқасы пластиктен жасалады. Оқшаулағыш материалдарды жылу сақтау үшін де қолдануға болады. Мысалы, термос немесе тоңазытқыш, Figure 3 а.



Figure 3

Бөлмедегі кез келген ағаш пен металл заттардың температурасы бірдей болғанымен, металл заттар суықтау сезілетінін байқадыңыз ба? Не себепті?

КОНВЕКЦИЯ ДЕГЕНІМІЗ НЕ?

Конвекция деп жылу энергиясының сұйықтың немесе газдың ағыны арқылы таралуын айтамыз. Бұл жағдайда молекулалар температурасы жоғары жерден температурасы төмен жерлерге қозғалу арқылы жылуды тасымалдайды, Figure 4. Конвекция орын алу үшін сұйықтық немесе газдың болуы міндетті.

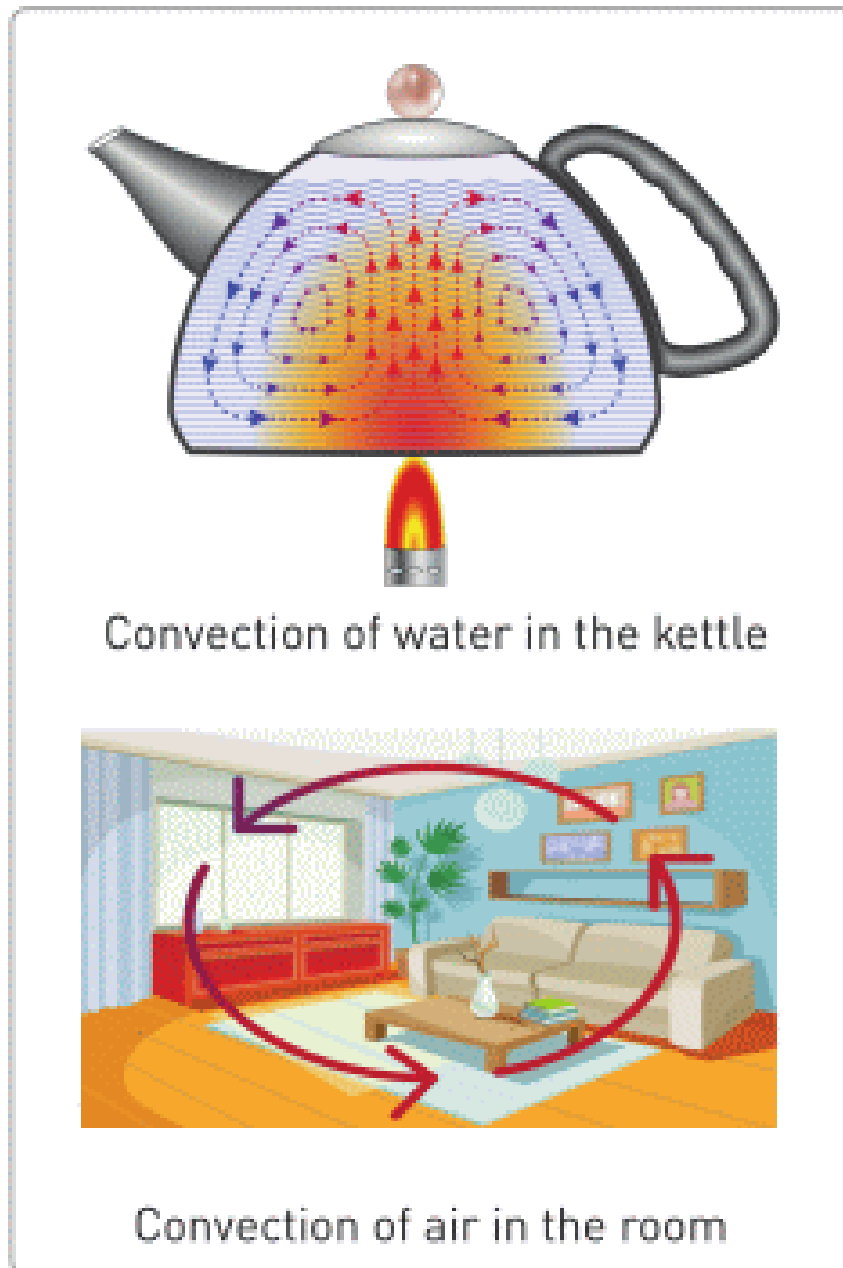

Figure 4

СӘУЛЕ ШЫҒАРУ ДЕГЕН НЕ?

Сәуле шығару кезінде жылу энергиясы электромагниттік толқындар арқылы тасымалданады. Сәуле шығару

ешқандай ортаны қажет ептейді. Мысалы, жылу Күннен Жерге дейін сәуле шығару арқылы жетеді, Figure 5. Алайда, Жер мен Күннің арасында "ешқандай" орта жоқ.

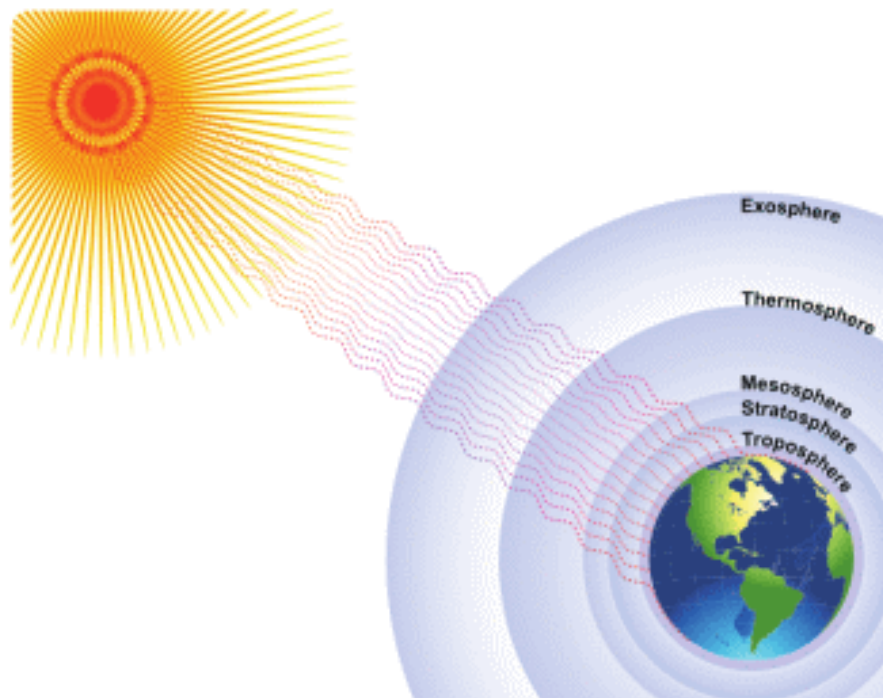

Figure 5

Қара түсті заттар радиацияны (сәуле шығаруды) жақсы қабылдайды. Сол себепті, жазда қара түсті киім адамды терлетеді.

Ақ және жалтырағыш заттар сәулені шағылдырып кері қайтарады. Сол себепті, өрт сөндірушілер ақшыл киім киеді. Ол ыстықтан қорғайды.

ACTIVITY

conduction
convection
radiation

Write down at least 2 examples for conduction, convection & radiation.

ACTIVITY

Discuss in groups which types of heat transfer these examples have.

1. Sun warming your face.
2. Switched on lamp.
3. A metal spoon in hot water.
4. Heat from a fire.
5. Radiator.
6. Ice on a sunny, windy day.
7. Vapour from the cup of tea.
8. Hair dryer.

RESEARCH TIME



Ақ және қара түсті екі құтыны суға толтырып күн көзіне қойыңыз, 1-2 сағаттан соң температураларын өлшеңіз.

LITERACY

1. Оттың түтіні не себепті жоғары көтеріледі?
2. Күннің көзі көлеңкеге қарағанда неге ыстығырақ?
3. Ыстық шәйнекті ұстаған кезде неге жылуды сеземіз?
4. Жазғы күндері неге ақтүсті киімдерді киген жақсырақ?
5. Неге батареялар көбінесе терезенің астына орнатылады?

6. Жылу алмасудың түрлерін атомдардың қозғалысы арқылы түсіндіріңіз.
7. Figure 6 жылу тасымалының моделі болып табылады. Не себепті?

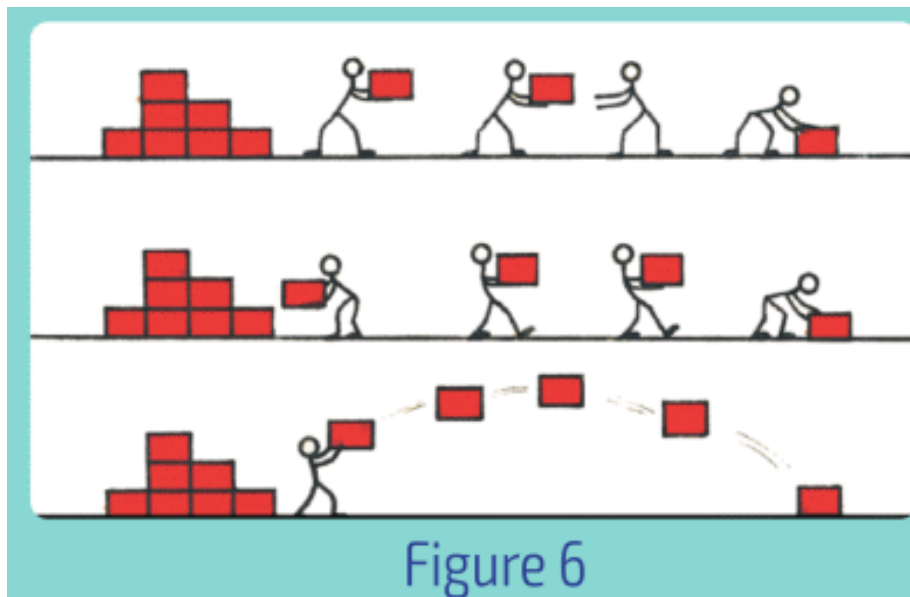

ART TIME

"Жылу өткізгіштік, конвекция және сәуле шығару" туралы өлең шығарыңыз. Шығарған өлеңіңізді ата-анаңызға, мұғалімдеріңізге және достарыңызға шырқап беріңіз.

FACT

Өсімдік майы жылу энергиясының біркелкі таралуына көмектеседі. Сондықтан, тамақ пісіруде өсімдік майы жиі қолданылады.

TERMINOLOGY

- collision – соқтығыс / соударение

- to prevent – болдырмау / предотвратить
- fluid – газ немесе сұйықтық / газ или жидкость
- to absorb – сіңіру / впитывать
- to reflect – шағылысу / отражать
- radiator – батарея / батарея

1.4 APPLICATION OF HEAT TRANSFER

TRANSFER

YOU WILL:

- - tell examples of heat transfer in daily life and industry;
- - tell examples of adaptation of living organisms to different temperatures.

QUESTION



Figure 1

Why do plastic windows, Figure 1, have layers and empty spaces? What may happen if we use only one layer of glass?

APPLICATION OF HEAT TRANSFER

Жылуды сақтау үшін оқшаулағыш материалдарды қолданған жөн. Мысалы, ауа - жақсы оқшаулағыш материал. Кейбір жануарлардың терісі немесе қауырсыны қалың болады, Figure 2.



Figure 2

Өйткені тері қаншалықты қалың болса, соншалықты көбірек ауа ұстап, жануарлардың суыққа қарсы төзімділігін арттырады.

Ертеректе аталарымыз ауаның осы қасиетін біліп, киізбен киіз үйлерін қаптаған, Figure 3.



Figure 3

Ал, қазіргі уақытта құрылысшылар ғимараттар жылы болуы үшін түрлі оқшаулағыш материалдарды қолданады, Figure 4 .

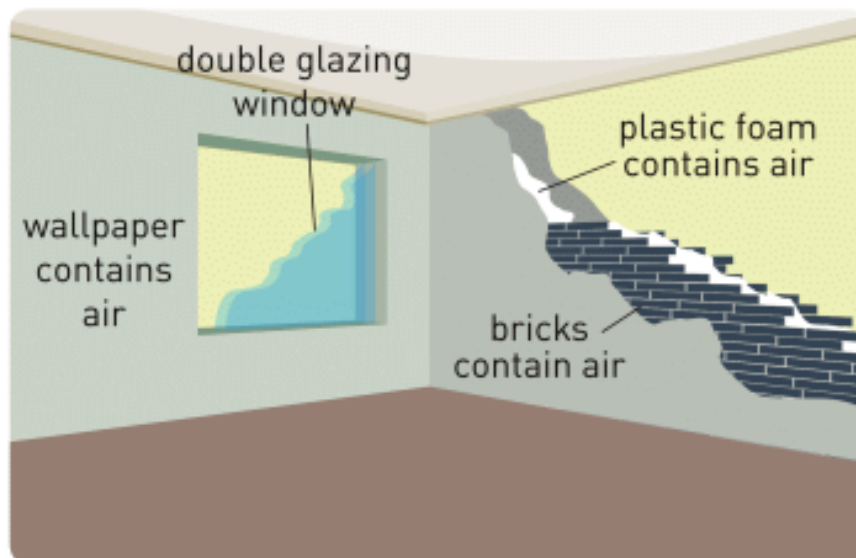

Figure 4

Материалдың түсі де жылу берілуіне әсер етеді. Мысалы, мұнай цистерналары ақ немесе ашық түспен боялады, Figure 5 . Себебі, ашық түс жарықты жақсы шағылдырып, цистерналар қатты қызбайды.



Figure 5

Ал, керісінше, жылу берілуін жылдамдату үшін не істеуге болады?

Оған мысал ретінде тоңазытқыш артындағы радиатор мен компьютер ішіндегі салқындатқышты келтірсек болады, Figure 6 . Бұл құрылғылар жылу алмасуды тездетеді.



Figure 6

ACTIVITY

Үйлерді және ғимараттарды жылытудың бірнеше жолы бар. Барлық жылыту жүйелері жылуөткізгіштік, конвекция және сәулеленуді қолданады. Жылыту жүйелерінде бу, жылы ауа және ыстық су қолданылады. Батареялар дала суыса неге тоқтамай істеп тұруы керек?

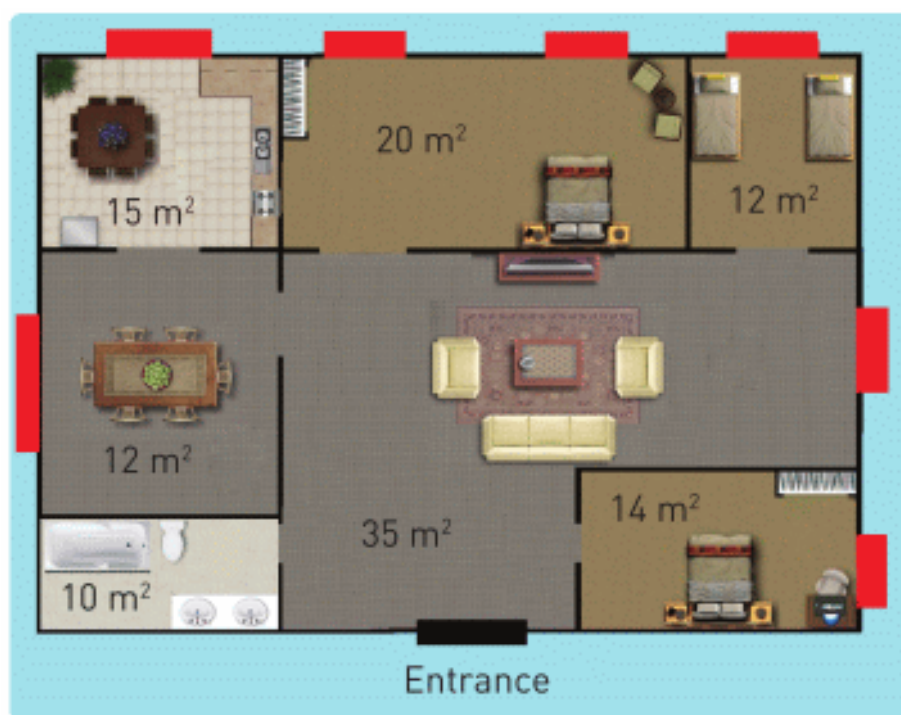

Бөлім 1.

Энергияны есептеу

Бұл бір үйдің сызбасы. Бөлмелердің ауданы суретте көрсетілген. Қызыл блоктар терезелер. Әр терезенің астында бір радиатордан орналасқан. Радиаторлар 1 м² ауданға 55 Ватт қуат өндіреді.

а) Әр бөлмеде радиаторлардың өндіретін толық қуатын есептеңіз. Бүкіл үйдегі барлық радиаторлардың өндіретін толық қуатын анықтаңыз.

ә) Үйдің қай бөлмесі салқындау болады? Себебін түсіндіріңіз.

Бөлім 2.

Жылу энергиясының түбіртегі

а) Бұл үйдің энергия шығынының тарифі айлық 1 м^2 ауданға 192.38 тг құрайды. 1 ай үшін және 6 ай үшін жылу энергиясының түбіртегін есептеңіз.

ә) Бөлім 1.а.-ның мәліметін пайдаланып, 1 айдағы жұмсалған жылу энергиясын есептеңіз.

(1 ай = 30 күн, 1 күн = 24 сағат, 1 сағат = 3600 секунд)

б) Жылу энергияның 1 Джоулінің құнын анықтаңыз.

Бөлім 3. Сызу

а) Өз үйіңіздің сызбасын салыңыз. Әр бөлменің ауданын жазыңыз.

ә) Үйіңіздегі барлық радиаторлардың толық қуатын есептеңіз.

б) 1 айдың жылу энергиясының түбіртегін есептеп шығарыңыз.

ФАКТ



Polar fox



Desert fox

Шөл түлкісінің құлақтары үлкен болады. Бұл оларға денесін салқын ұстауға көмектеседі.

RESEARCH TIME

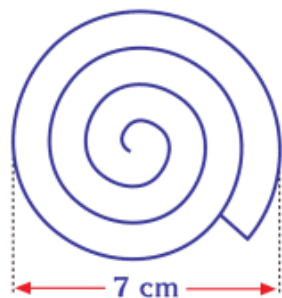

Draw a spiral on a piece of paper. Cut it out. Attach it to a thread. Put it over a lamp or a radiator and observe what happens.

RESEARCH TIME

Draw poster about sea breeze and land breeze. Explain why they occur.

LITERACY

1. Неліктен жорғалаушылар (жыландар, тасбақалар, қолтырауындар, кесірткелер) Солтүстік полюсті мекендемейді?
2. Жорғалаушылар күнге жылынуының себебі қандай? Бұл жылу алмасудың қандай түрі?
3. Суық жел индексі: Жылдамдығы 1 м/с жел ауа температурасын 2°C төмендетеді. Даланың температурасы -30°C және де желдің жылдамдығы 5 м/с болса, сезілетін температураны табыңыз. Адамдар суық жел индексін не үшін қолданады? Бұл жылу алмасудың қандай түрі?
4. Термометрді қалың жүнмен орап тастаса, оның көрсеткіші қалай өзгереді?

ART TIME

What materials would you use to make a good thermos?
Make a thermos (vacuum flask) and show it to your parents, teachers and friends.

TERMINOLOGY

- to reduce – азайту / уменьшать
- steam – бу / пар
- to bask in the sun – күнге жылыну / греться под солнцем
- wind chill index – жел суықтығы көрсеткіші / ветро-холодовой индекс

1.5 SPECIFIC HEAT CAPACITY

YOU WILL:

- - determine heat lost and heat given during heat transfer;
- - explain physical meaning of specific heat capacity.

QUESTION



Ш

During the day the Sun heats the beach and the lake equally. Why water is warm and sand is cold after sunset? Which one stores more heat? What is the best time for swimming? Explain your answers.

SPECIFIC HEAT CAPACITY

Жылу – энергияның бір түрі. Оның өлшем бірлігі – Джоуль. Кез келген дененің температурасын арттыруға

керекті жылу мөлшері үш параметрге байланысты:

1. ДЕНЕ МАССАСЫ

Массасы үлкен денелерді қыздыру үшін көбірек жылу қажет.

Мысалы, 1 кг судың температурасын 2°C -қа арттыру үшін 8400 Дж жылу энергиясы керек. Ал, 2 кг суды дәл солай жылыту үшін 16800 Дж жылу энергиясы керек.

2. ДЕНЕ МАТЕРИАЛЫНЫҢ ТҮРІ

1 кг темірді 1°C -қа қыздыруға 460 Дж кетеді. Ал, 1 кг суды 1°C -қа қыздырсақ, 4200 Дж жылу энергиясы кетеді. Себебі, су мен темір әртүрлі бөлшектерден (атомдар және молекулалар) құралған.

Кез келген 1 кг заттың температурасын 1°C -қа арттыру үшін қажетті энергия мөлшері заттың меншікті жылусыйымдылығы деп аталады. Бұл шама $[c]$ әрпімен белгіленеді және өлшем бірлігі $[\text{Дж}/\text{кг}^{\circ}\text{C}]$ болады.

Мысалы, $c_{\text{су}} = 4200 \text{ Дж}/\text{кг}^{\circ}\text{C}$, $c_{\text{темір}} = 460 \text{ Дж}/\text{кг}^{\circ}\text{C}$. Заттың меншікті жылусыйымдылығы жоғары болған сайын оны жылыту үшін көбірек энергия қажет болады. Мысалы, темірді қыздырғаннан гөрі суды қыздырған кезде көбірек энергия жұмсалады.

Басқа да заттардың меншікті жылусыйымдылықтары Table 1.5 кестесінде көрсетілген.

Substance	c [J/kg°C]	Substance	c [J/kg°C]
Alcohol (ethyl)	2450	Lead	130
Aluminum	900	Marble	880
Brass	380	Mercury	140
Carbon	710	Silver	235
Copper	400	Gold	130
Glass	670	Water	4200
Glycerine	2410	Water vapour	2100
Ice	2100	Wood	1750
Iron	460	Zinc	380

Table 1.5

3. ДЕНЕ ТЕМПЕРАТУРАСЫНЫҢ ӨЗГЕРІСІ

Температураның өзгерісі тікелей берілген жылу энергиясының мөлшеріне тәуелді.

1 кг қорғасынды 1°C-ге жылыту үшін, 130 Дж жылу керек.

2°C-ге жылыту үшін, 260 Дж жылу керек.

3°C-ге жылыту үшін, 390 Дж жылу керек.

Бұл мысалдағы 1°C, 2°C, 3°C температураның өзгерістері.

Температура өзгерісін ΔT деп белгіленеді.

$\Delta T = T_{\text{соңғы}} - T_{\text{бастапқы}}$

$$\Delta T = T_{\text{final}} - T_{\text{initial}}$$

Дененің массасын, меншікті жылусыйымдылығы және температура өзгерісін келесі формула арқылы байланыстыруға болады:

$$Q = m \times c \times \Delta T$$

Q	=	m	×	c	×	ΔT
heat		mass		specific heat capacity		Temperature change
(Joules, J)		(kilograms, kg)		(J/kg°C)		(degrees of Celsius or Kelvin)

FACT



Судың жылу сыйымдылығы Жер шары үшін өте маңызды. Себебі ол Жер шарының "жылу радиаторы" қызметін атқарады. Күні бойы Күн сәулесінен алған жылуды өз бойына сақтап, күн батқаннан таң атқанға дейін жылуын беріп тұрады.

DISCUSSION

Table 1.5-тегі көрсетілген жылу сыйымдылықтары үлкен немесе кішірек болғанда не болар еді? Адам өміріне оның әсері қанша? Мысалдарды суреттеңіз. Кем дегенде екі оң, екі теріс әсерін айтып беріңіз

DISCUSSION

Can you give an example where water can be used to remove heat (to cool objects)?

EXAMPLE

How much energy is needed to heat 2 litres of water from 25°C to 100°C?

Solution:

For water

1 litre = 1 kilogram

Formula:

$$Q_{\text{water}} = m \times c \times \Delta T$$

$$\Delta T = T_f - T_i \text{ (change in temperature)}$$

Calculation:

$$Q_{\text{water}} = 2 \text{ kg} \times 4200 \frac{\text{J}}{\text{kg}^{\circ}\text{C}} \times (100^{\circ}\text{C} - 25^{\circ}\text{C})$$

$$Q_{\text{water}} = 630\,000 \text{ J} = 630 \text{ kJ}$$

ACTIVITY

Күнделікті өмірде кей жағдайда бізге меншікті жылусыйымдылығы төмен материал қажет. Мысалы, таба. Ал, кейбір жағдайда бізге меншікті жылусыйымдылығы жоғары, кірпіш сияқты материал қажет.

Table 1.5-тен 2 материал таңдап, мына сұрақтарға жауап беріңіз.

- а) Оларды қай жерде қолданған дұрыс?
- ә) Оларды қай жерде қолданбаған дұрыс?
- б) Мысалдарыңызды түсіндіріңіз.





ART TIME

Write a poem about specific heat capacity. Read it to your parents, teachers and friends.

LITERACY

1. Жаз мезгілінде көл (теңіз) күндіз салқын, ал жағажай жылы болып тұрады. Не себепті?
2. Сізде темір, сынап, алюминий және қорғасын бар. Әрқайсысының массасы 3 кг, температурасы 25°C . Барлығына бірдей 5000 Дж беріңіз. Материалдардың соңғы температурасын өсу ретімен жазыңыз.
3. Машинаның радиаторында су бар. Машина қозғалтқышы істеп тұрғанда, оның температурасы шамамен 95°C . Егер де су болмаса, қозғалтқыш температурасы 120°C дейін жетіп, істен шығады. Қозғалтқыш үшін су соншалықты не үшін маңызды? Адамдар басқа сұйықтықты қолданса не болар еді?

TERMINOLOGY

- to store – сақтау / хранить
- substance – зат / вещество
- relation – байланыс / связь
- engine – қозғалтқыш / двигатель
- specific – меншікті / удельная

1.6 HEAT OF COMBUSTION

YOU WILL:

- apply the formula of the heat of combustion to solve problems.

QUESTION

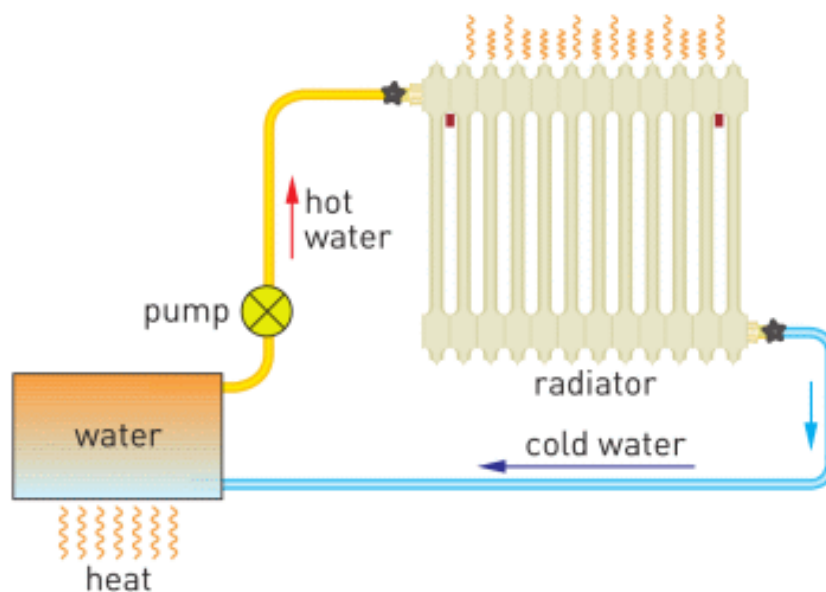

This is a model of a heating system that uses convection. Water is heated. Then pump sends water to the radiator. How do people heat the water?

HEAT OF COMBUSTION

Энергияның адам өміріндегі алатын орны ерекше. Әдетте, энергияны көмір, жанармай немесе табиғи газ сияқты отынды жағу арқылы аламыз. Көліктер, пойыздар, ұшақ

пен кемелердің қозғалуына және ғимараттарды жылытуға отын қажет. Алайда, отынның ең негізгі қолданылу аясы электр энергиясын өндіру болып табылады, Figure 1.



Figure 1

Отын жану үшін екі факторды қажет етеді: ауа (оттек) және жану процесін өршітетін бастапқы жылу (тұтану температурасы), Figure 2.

Жану кезінде отын қаншалықты көп болса, соншалықты сыртқа көбірек энергия бөлінеді. 1 кг отыннан алынатын жылу мөлшері меншікті жану жылуы деп аталады.

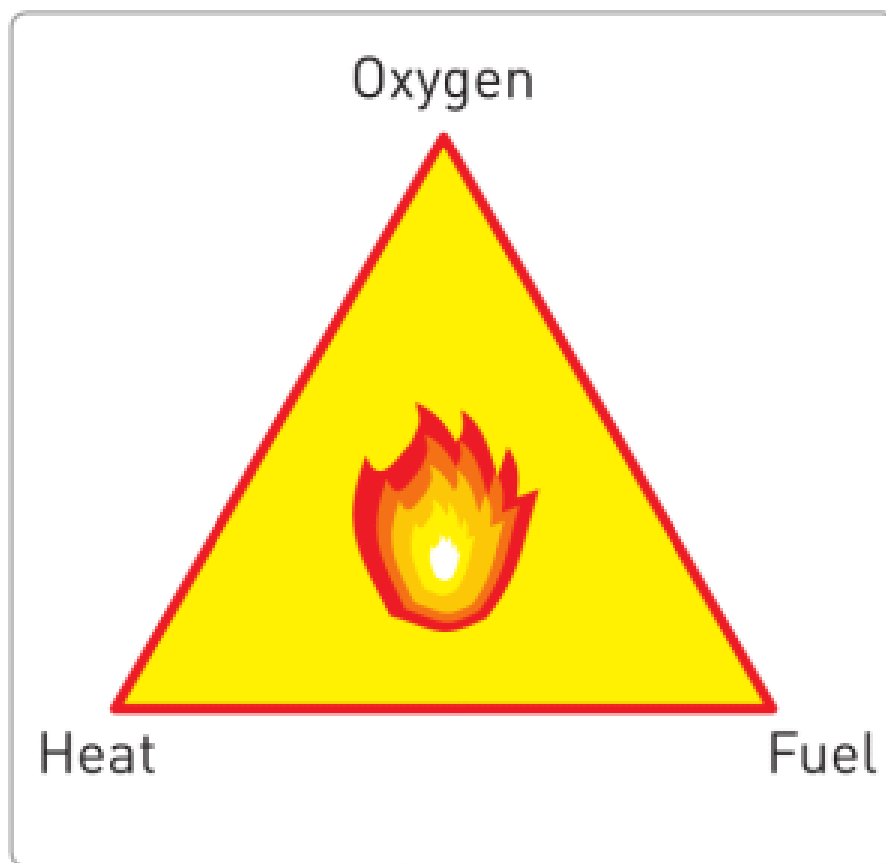

Figure 2

Төмендегі кестеде әртүрлі отын үшін жану жылулары берілген.

Мысалы, 1 кг ағаш толық жанғанда 15000000 Дж энергия бөлінеді.

Осы тақырыптағы үлкен сандарды жазуға қолайлы болуы үшін М (Мега = 10^6) сөз алды қосымшасын қолдануға тура келеді. Мысалы, 15000000 Дж = 15 МДж.

Fuel	MJ/kg	Fuel	MJ/kg
Black coal	36.0	Hydrogen	141.9
Brown coal	15.0	Natural gas	54.0
Diesel	45.0	Propane	49.0
Alcohol	29.7	Wood	15.0

If the burning fuel has mass m , the total heat obtained from combustion is:

Q	=	m	×	q
heat (Joules, J)		mass (kilograms, kg)		heat of combustion (J/kg)

Отын жануы үшін, ең алдымен, оның температурасы белгілі дәрежеге дейін жетуі керек. Бұл температура тұтану температурасы деп аталады. Мысалы, қағаз бен ағаш блокты қарастырайық, Figure 3.

Ағаш блоктың тұтану температурасы жоғары. Сол себепті ағашты тұтату қағазды тұтатқаннан қиынырақ.

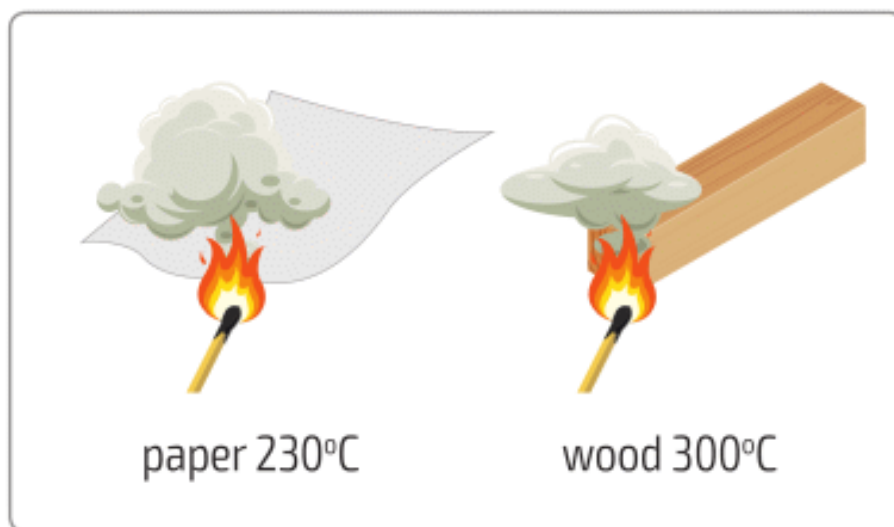

Figure 3

Жанған отты сөндірудің 2 жолы бар. Біріншісі, жапқышпен, құммен немесе балшықпен жабу арқылы оттектен бөгеу. Екіншісі, жанғыш заттың температурасын төмендету. Күнделікті өмірде отты сөндіру үшін өрт сөндіргіштер қолданылады. Олардың бірнеше түрлері болады, Figure 4.



Figure 4

EXAMPLE

How many kilograms of coal do you need to get 1500 kJ energy? $q = 30 \text{ MJ/kg}$

Solution:

We need to find mass of the coal.

$$Q = m \times q \Rightarrow m = \frac{Q}{q} \quad m = \frac{15 \times 10^5 \text{ J}}{3 \times 10^7 \frac{\text{J}}{\text{kg}}} = 5 \times 10^{-2} \text{ kg} = 50 \text{ g}$$

FACT



Sometimes people burn a small part of a forest to stop approaching huge fire wave. This is called controlled burning.

RESEARCH TIME



Стакан мен кішігірім майшам алыңыз. Майшамды жағыңыз да, үстінен стаканды жабыңыз. Не болады екен?

LITERACY

1. а) Автомашина 100 км жолға 10 литр бензин жұмсайды. Астана Алматы арасындағы жолға (1300 км) қанша литр бензин жұмсалады? ә) Қанша килограмм бензин жұмсалады? (1000 литр 1 м^3 -ке тең. 1 м^3 -те 700 кг бензин бар) б) Жолға қанша Джоуль энергия жұмсалады? (1 кг бензин 42 МДж береді)
2. Космонавт айда кәуәп пісіргісі келсе не болады?



3. Газ пештің үстінде 0.5 кг су 20°C-тан 100°C-қа дейін қыздырылады. Бұл үшін қанша килограмм газ қажет? (1 кг газ 54 МДж береді. 1 кг суды 1°C-қа қыздыру үшін 4200 Дж жылу қажет).

ART TIME

Think up and draw a plan for controlled burning. Show it to your parents, friends, and teachers.

TERMINOLOGY

- fuel – жанғыш зат / топливо
- oxygen – оттегі / кислород
- to generate – өндіру / производить
- gasoline – бензин / бензин
- hydrogen – сутегі / водород
- combustion – жану / горение
- fire extinguisher – өрт сөндіргіш / огнетушитель

1.7 HEAT EXCHANGE

YOU WILL:

- - apply equation of heat balance to solve problems.

QUESTION



A 4 year-old kid can drink tea if the temperature is not greater than 40°C . You have a cup of tea at 90°C . What should you do to decrease the temperature of tea? Can you find several methods?

HEAT EXCHANGE

Жылу энергиясы ардайым ыстықтан суыққа қарай тасымалданады, Figure 1.

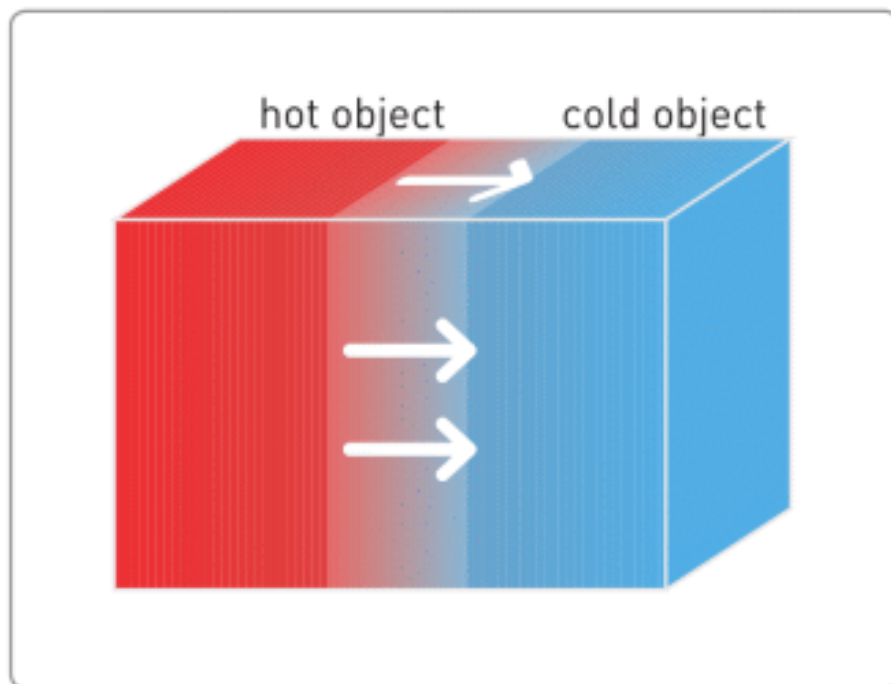

Figure 1

Екі дененің температуралары теңескенде, жылу алмасу тоқтайды. Осы кезде денелер термалды тепе-теңдікте болады. Соңғы температура (T_f), екі денелердің бастапқы температураларының арасында болады. Мысал ретінде Figure 2. Жылу алмасудан кейін денелердің соңғы ортақ температурасы 20°C -тан жоғары, бірақ 60°C -тан төмен болады.

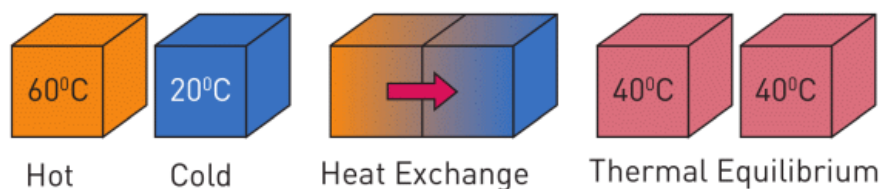

Figure 2

Ыстық денеден бөлінген жылу мөлшері суық денеге берілген жылуға тең болады.

Бұл принцип энергияның сақталуы деп аталады. Оны формула жүзінде былай жазуға болады:

– Heat lost by hot object = Heat gained by a cold object

$$-Q_{\text{lost}} = Q_{\text{gained}}$$

$$-m_{\text{hot}} \times c_{\text{hot}} \times \Delta T_{\text{hot}} = m_{\text{cold}} \times c_{\text{cold}} \times \Delta T_{\text{cold}}$$

$$-m_{\text{hot}} \times c_{\text{hot}} \times (T_{\text{final}} - T_{\text{hot}}) = m_{\text{cold}} \times c_{\text{cold}} \times (T_{\text{final}} - T_{\text{cold}})$$

$$m_{\text{hot}} \times c_{\text{hot}} \times (T_{\text{hot}} - T_{\text{final}}) = m_{\text{cold}} \times c_{\text{cold}} \times (T_{\text{final}} - T_{\text{cold}})$$

Жоғарыдағы теңдеуді тек тұйықталған ортада, яғни қоршаған ортамен жылу алмасу болмаған кезде ғана қолдануға болады. Сыртқы ортамен жылу алмасуды азайту үшін калориметр қолданылады.

Калориметр дегеніміз қоршаған ортамен жылу алмасуды жақсы оқшаулайтын құрылғы. Оны меншікті жылусыйымдылығы төмен металдан жасайды. Ыдыстың сыртына оқшаулағыш материалдан жасалған қалбыр кигізіледі, Figure 3. Калориметрдің ішіндегі заттардың ішкі энергиясы бір қалыпты болады деп қабылдауға болады.

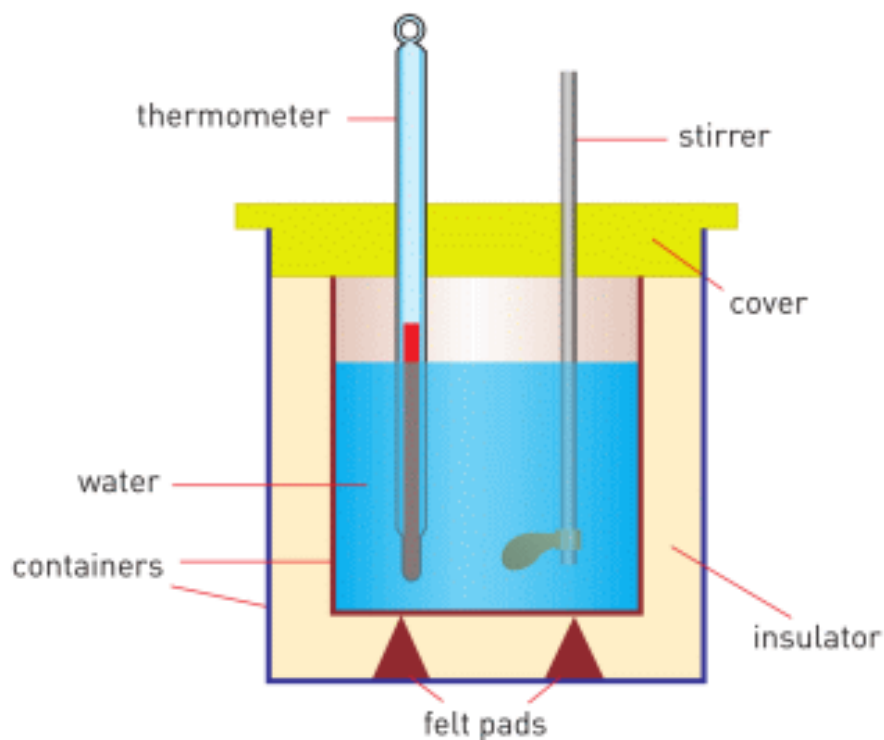

Figure 3

ACTIVITY

Жылу алмасу дегеніміз энергияның бір жерден екінші жерге тасымалдануы. Ыстық атомдар және суық атомдарды елестетіп, ыстық атомдардың суық атомдарға қалай энергия беретінін суреттеп беріңіз.

EXAMPLE

In a laboratory, a student mixed 200 g water at 70°C with 100 g water at 40°C. Find the final temperature of the mixture.

Solution:

Given:

hot water: $m_1 = 200 \text{ g}$; $T_1 = 70 \text{ }^\circ\text{C}$
 cold water: $m_2 = 100 \text{ g}$; $T_2 = 40 \text{ }^\circ\text{C}$

Solution:

$$-Q_{\text{lost}} = Q_{\text{gained}}$$

$$-m_1 \times c_{\text{water}} \times \Delta T_1 = m_2 \times c_{\text{water}} \times \Delta T_2$$

$$-0.2 \text{ kg} \times 4200 \frac{\text{J}}{\text{kg}^\circ\text{C}} \times (T_f - 70^\circ\text{C}) = 0.1 \text{ kg} \times 4200 \frac{\text{J}}{\text{kg}^\circ\text{C}} \times (T_f - 40^\circ\text{C})$$

$$0.2 \times (70 - T_f) = 0.1 \times (T_f - 40)$$

$$14 - 0.2 \times T_f = 0.1 \times T_f - 4$$

$$18 = 0.3 \times T_f$$

$$T_f = \frac{18}{0.3} = 60 \text{ }^\circ\text{C}$$

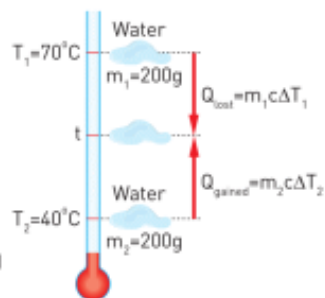

DISCUSSION

There are two large and one small container. The first one is filled with water at 90°C , the second with water at 20°C , the third container is empty. How can we obtain water at these temperatures?

- a) 50°C
- b) 40°C
- c) 55°C
- d) 85°C
- e) 21°C
- f) 20.1°C
- g) 89.9°C

FACT



When we are sick, we have high temperature. Then we put wet towel on a forehead. This is done to decrease temperature of our head. Molecules of water take heat from our head.

LITERACY

1. Температурасы 20°C 1 стакан суды температурасы 80°C 1 стакан сумен араластырсақ, қоспаның температурасы неге тең болады?
2. Егер температурасы 20°C 1 стакан суды температурасы 80°C 2 стакан сумен араластырса, қоспаның температурасы неге тең болады?
3. Егер температурасы 20°C 2 стакан суды температурасы 80°C 1 стакан сумен араластырса, қоспаның температурасы қалай өзгереді?
4. Егер температурасы 20°C 2 стакан суды температурасы 80°C 2 стакан сумен араластырса, қоспаның температурасы неге тең болады? Себебі?

ART TIME

Can you do theatre play that explains “heat exchange”? What roles can you play? Show theatre play to parents, teachers and friends.

TERMINOLOGY

- heat lost – жоғалған жылу / потерянное тепло
- heat gained – алынған жылу / приобретенное тепло
- conservation of energy – энергияның сақталуы / сохранение энергии
- surrounding – қоршаған орта / окружающая среда

LABWORK 1

TITLE:

Conservation of energy in heat transfer

OBJECTIVES:

1. To measure the final temperature.
2. To apply the specific heat capacity equation for calorimetry to calculate the final temperature of the mixture.
3. To identify the cause of the difference between measured temperature and calculated temperature.

MATERIALS LIST:

1. calorimeter
2. hot water
3. cold water
4. electronic (or mechanical) scales
5. thermometer
6. hot plate
7. stirring rod
8. two beakers



SAFETY:

1. When using a burner or hot plate, always wear goggles and an apron to protect your eyes and clothing. Tie back long hair, secure loose clothing, and remove loose jewellery. In a case of emergency, call a teacher.
2. Never leave a hot plate unattended while it is turned on.
3. If a thermometer is broken, notify the teacher immediately.
4. Do not heat glassware that is broken, chipped, or cracked. Use tongs or a mitt to handle heated glassware and other equipment because it does not always look hot when it actually is. Allow all equipment to cool before storing it.
5. Never put broken glass or ceramics in a regular waste container. Use a dustpan, brush, and heavy gloves to

carefully pick up broken pieces and dispose of them in a container specifically provided for this purpose.

THEORY:

$$Q = m \times c \times \Delta T$$

$$-Q_{\text{lost}} = Q_{\text{gained}}$$

$$Q = m \times c \times \Delta T$$

$$-Q_{\text{lost}} = Q_{\text{gained}}$$

- What is Q? What is the unit of measurement of Q?
- What is m? What is the unit of measurement of m?
- What is c? What is the unit of measurement of c?
- What is ΔT ? What is the unit of measurement of ΔT ?
- What will give heat? Cold water or hot water? Why?
- What will take the heat? Cold water or hot water? Why?
- Which one will be bigger, heat given or heat taken? Why?

PROCEDURE:

1. Read the entire lab procedure, and plan the steps you will take. Determine which steps can be performed while

- you are waiting for the water to heat.
2. Record your data in the data table.
 3. Choose a location where you can set up the experiment away from the edge of the table and from other groups. Make sure the switch of the hot plate is in the “off” position before you plug it in.
 4. Turn on the hot plate and adjust the heating control to heat the water.
 5. Use the thermometer to measure the temperature of the hot water and cold water. (Note: When making temperature readings, take care not to touch the hot plate and the water.)
 6. Use the scales to measure the mass of the hot water and cold water.
 7. Use the stirring rod to gently stir the mixture of hot water and cold water in the calorimeter. Do not use the thermometer to stir the water.
 8. Clean up your work area. Put equipment away safely so that it is ready to be used again.

ANALYSIS:

1. Calculate the final temperature of the mixture.
2. Measure the final temperature of the mixture.
3. Calculate the energy transferred to the cold water.
4. Calculate the energy transferred from the hot water.

CONCLUSIONS:

1. Explain why the energy transferred as heat to the cold water is equal to the energy transferred as heat from the hot water.
2. Explain why calculated and measured temperatures of the mixture are different (or same).

3. How would your results be affected if the initial temperatures of the water in the beakers were equal?
4. What is the purpose of the calorimeter in this experiment?

SUMMARY

- Atom: a particle that consists of protons, neutrons and electrons; atom determines a type of substance.
- Molecule: a group of atoms that are connected to each other.
- Diffusion: molecules move from higher concentration to lower concentration.
- Temperature: a measure of speed and mass of molecules, a measure of the average kinetic energy of molecules.
- Thermometer: an instrument that measures temperature.
- Absolute zero: -273°C , there cannot be a lower temperature than -273°C .
- Celsius scale, Kelvin scale: different temperature scales. Celsius scale is used in everyday life. Kelvin scale is used in science.
- Internal energy: a sum of all kinetic energies of atoms and molecules of a substance.
- Conduction: heat flow by the collision of hotter particles to colder particles.
- Convection: heat flow by movement of a fluid (liquid or gas).
- Radiation: heat flow by electromagnetic waves.
- Specific heat capacity: energy needed to increase the temperature of 1 kg of a substance by 1°C .

- $Q = m \times c \times \Delta T$

- 

$$\begin{array}{ccccccc} Q & = & m & \times & c & \times & \Delta T \\ \text{heat} & & \text{mass} & & \text{specific heat capacity} & & \text{Temperature change} \\ \text{(Joules, J)} & & \text{(kilograms, kg)} & & \text{(J/kg}^{\circ}\text{C)} & & \text{(degrees of Celsius or Kelvin)} \end{array}$$

- Heat of combustion: energy you get from burning 1 kg of fuel.

- $Q = m \times q$

-

$$Q_{\text{heat}} \text{ (Joules, J)} = m_{\text{mass}} \text{ (kilograms, kg)} \times q_{\text{heat of combustion}} \text{ (J/kg)}$$

- – Heat lost by hot object = Heat gained by cold object
- $-Q_{\text{lost}} = Q_{\text{gained}}$

$$-Q_{\text{lost}} = Q_{\text{gained}}$$

$$-m_h \times c_h \times \Delta T_h = m_c \times c_c \times \Delta T_c$$

$$-m_h \times c_h \times (T_f - T_h) = m_c \times c_c \times (T_f - T_c)$$

$$m_h \times c_h \times (T_h - T_f) = m_c \times c_c \times (T_f - T_c)$$

PROBLEMS

THERMAL MOTION

1. Simple diffusion is defined as the movement of

A. Molecules from areas of higher concentration to areas of lower concentration

B. Molecules from areas of lower concentration to areas of higher concentration

C. Water molecules across a membrane

D. Gas molecules across a membrane

E. Gas or water molecules across a membrane

2. When sugar is mixed with water, equilibrium is reached when

A. Molecules of sugar stop moving

B. Water and sugar molecules are moving at the same speed

C. The dissolved sugar molecules are evenly distributed throughout the solution

D. There is the same number of water molecules as dissolved sugar molecules

E. Two tablespoons of coffee are added

3. Which of the following affect(s) the speed of diffusion?

- A. Temperature
- B. Size of molecules
- C. Concentration difference
- D. A and B
- E. A, B and C

4. The molecules in a solid lump of sugar do not move

- A. True
- B. False

TEMPERATURE AND INTERNAL ENERGY

1. What is an acceptable temperature for a comfortable room?

- A. 72 degrees Kelvins
- B. 72 degrees Celsius
- C. neither

D. both

2. Which of the followings can be a temperature of an ice cream?

A. 30 degrees Celsius

B. 250 degrees Kelvins

3. Which of the followings can be a temperature of a cup of tea?

A. 228 degrees Kelvins

B. 28 degrees Celsius

4. True or False? 260 Kelvins is a reasonable temperature for warm spring day.

A. True

B. False

5. Choose the reasonable temperature for a glass of iced tea?

A. 32 degrees Celsius

B. 4 degrees Celsius

C. neither

6. Which one is better to wear when the weather is 29°C ?

- A. t-shirt
- B. sweater
- C. heavy coat and gloves
- D. none of the above

7. What would you most likely to wear on a day that is 255 Kelvins?

- A. t-shirt
- B. heavy coat, hat, scarf, gloves
- C. sweater

8. Choose what you would most likely to wear on a day that is 300 Kelvins.

- A. sweater
- B. t-shirt
- C. heavy coat and gloves

9. If it was 218 Kelvins outside, what would you most likely be doing?

- A. sledding
- B. swimming
- C. water skiing

10. Choose the word that might describe a 32 degrees of Celsius day.

- A. freezing
- B. warm
- C. cold
- D. windy

11. Convert the following units into the desired ones.

- a) $86\text{ K} = \dots\dots\dots\text{ }^\circ\text{C}$ b) $373\text{ K} = \dots\dots\dots\text{ }^\circ\text{C}$
- c) $40\text{ }^\circ\text{C} = \dots\dots\dots\text{ K}$ d) $75\text{ }^\circ\text{C} = \dots\dots\dots\text{ K}$

12. A liquid boils at 351 K. What is this temperature in $^\circ\text{C}$?

13. A weather forecast announces that the expected daytime temperature is 293 K. What is the temperature in $^\circ\text{C}$?

14. Which is the greater temperature, 25°C or 308 K?

15. Referring to the information given on page 11, calculate the temperature of the centre of the sun, a light bulb filament and a Bunsen flame in degrees of Kelvin.

FILL IN THE BLANKS

16. When a substance is heated, its particles gain and move rapidly.

17. The temperature of a substance is a measure of the average energy of each particle in it.

18. Heat is the energy transferred to a substance, while temperature is the degree of of a substance.

19. On the scale pure water freezes at 0 °C.

20. On the Celsius scale, the of the boiling point of water is marked as °C.

21. Household thermometers usually include as the capillary liquid and they have a range of temperatures from $-30\text{ }^{\circ}\text{C}$ to $50\text{ }^{\circ}\text{C}$.

HEAT

1. How much heat is needed to raise the temperature of 1000 g of solid ice from $0\text{ }^{\circ}\text{C}$ to $40\text{ }^{\circ}\text{C}$?

2. How much heat is needed to change the temperature of 200 g of water from $10\text{ }^{\circ}\text{C}$ to $50\text{ }^{\circ}\text{C}$?

3. How many Joules of heat are lost when 100 g of iron cools from $120\text{ }^{\circ}\text{C}$ to $50\text{ }^{\circ}\text{C}$?

4. How many Joules of heat are lost when the temperature of 300 g copper drops by $20\text{ }^{\circ}\text{C}$?

5. Assuming that no heat is lost to the surroundings, calculate the final temperature when 50 g of water at $30\text{ }^{\circ}\text{C}$ are mixed with 25 g of water at $60\text{ }^{\circ}\text{C}$.

6. Calculate the quantity of heat needed to change 60 g of water at 100 °C into steam at 100 °C.

7. 10 g of ice at 0 °C is dropped into 90 g of water at 70 °C. Calculate the final temperature of mixture.

8. 200 g of olive oil at 80 °C is in a container. If another 50 g of olive oil at 20 °C is added to the container, what will the final temperature be? (Heat exchange with the container is ignored.)

9. If 100 g of iron at 100 °C is dropped into 390 g of water at 20 °C, what will the final temperature be?

APPLICATION OF HEAT TRANSFER

FILL IN THE BLANKS WITH APPROPRIATE WORDS

1. keeps animals warmer in winter.

2. Firemen wear suits.
3. Metals are generally conductors of heat.
4. keeps hot liquid hot for a long time.
5. In space, matter does not exist so convection and..... do not occur.
6. Bright shiny surfaces are emitters of heat.

ANSWER THE QUESTIONS

1. What is the difference between conduction and convection? Explain by using examples.
2. Explain why a double glazed window keeps rooms warm.
3. Why do we wear thick clothes in winter and bright clothes in summer?

4. How does fur keep animals warm?

5. Explain coastal breezes.

6. What are good and bad absorbers of radiation? Give examples.

7. What are good and bad emitters of radiation? Give examples.

8. Explain how home heating systems work.

9. Can heat be transferred by convection in a solid? Why?

ANSWER THE TEST QUESTIONS-I

1. The measure of the average kinetic energy of particles in matter is called:

A) Heat

- B) Temperature
- C) Calorie
- D) Heat of fusion

2. The instrument which is used to measure temperature is called:

- A) Manometer
- B) Barometer
- C) Altimeter
- D) Thermometer

3. A normal human body temperature is about $36\text{ }^{\circ}\text{C}$. Which of the following expresses this temperature in Kelvin?

- A) 400 K
- B) 305 K
- C) 309 K
- D) 500 K

4. The metal sodium melts at 371 K. What is the melting point of sodium on the Celsius temperature scales?

- A) $98\text{ }^{\circ}\text{C}$

- B) 90 °C
- C) 100 °C
- D) 110 °C

5. Which of the following has no effect on the amount of expansion of a body?

- A) Dimensions of the body
- B) Temperature change
- C) Type of matter a body is composed of
- D) Colour of the body

ANSWER THE TEST QUESTIONS-II

1. Which one of the substances below is the best conductor of heat?

- A) paper
- B) glass
- C) nail
- D) wool

2. Which one of the substances below is the best insulator of heat?

- A) glass
- B) hard plastic
- C) copper
- D) air

3. Why does conduction not occur in space?

- A) Because no matter exists in space
- B) Because only convection occurs
- C) Because the sun is far away from the earth
- D) Because the moon prevents heat transfer

4. I. White coloured surface

II. Blackened surface

III. Insides of a toaster

IV. Reflector of an electrical heater

Which of the above is a good absorber of heat?

- A) I, II

B) II, III

C) I, IV

D) II, IV

5. The Sun heats us by the method of

A) isolation

B) conduction

C) convection

D) radiation

PHYSICS IN LIFE

1. Skin of a polar bear is black. Fur is 10 cm thick. How does it help?



2. The gas pressure in a light bulb is 0.7 atm? Why is it lower than atmosphere's pressure?



3. Yurt is a house of nomads. Why did they use thick wool to make yurts?

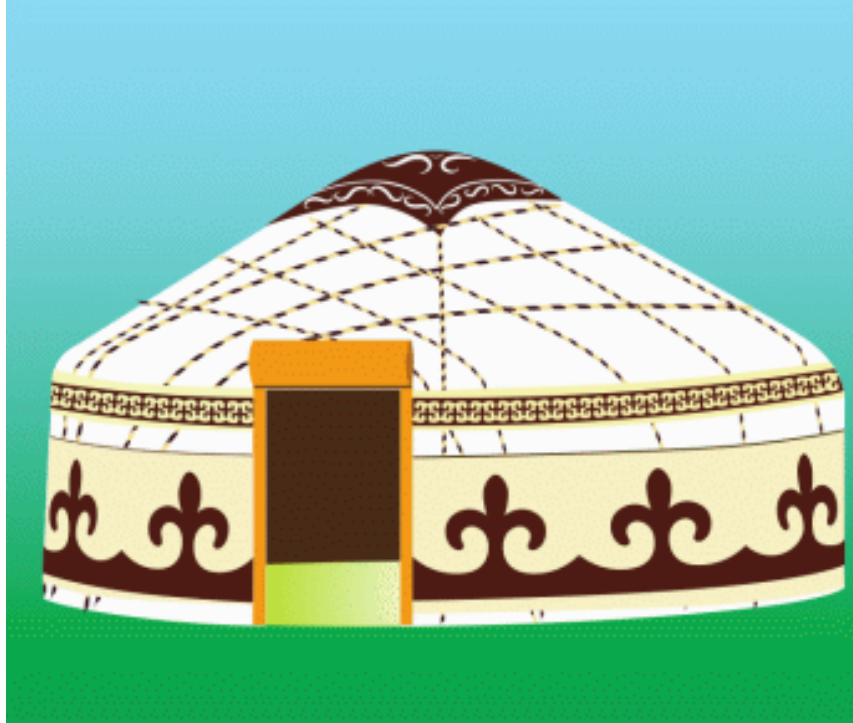

4. If all water disappears, the average temperature on Earth will be 67 °C. Why the temperature rises?



5. Venus is farther from the sun than Mercury. Why is then Venus hotter than Mercury?

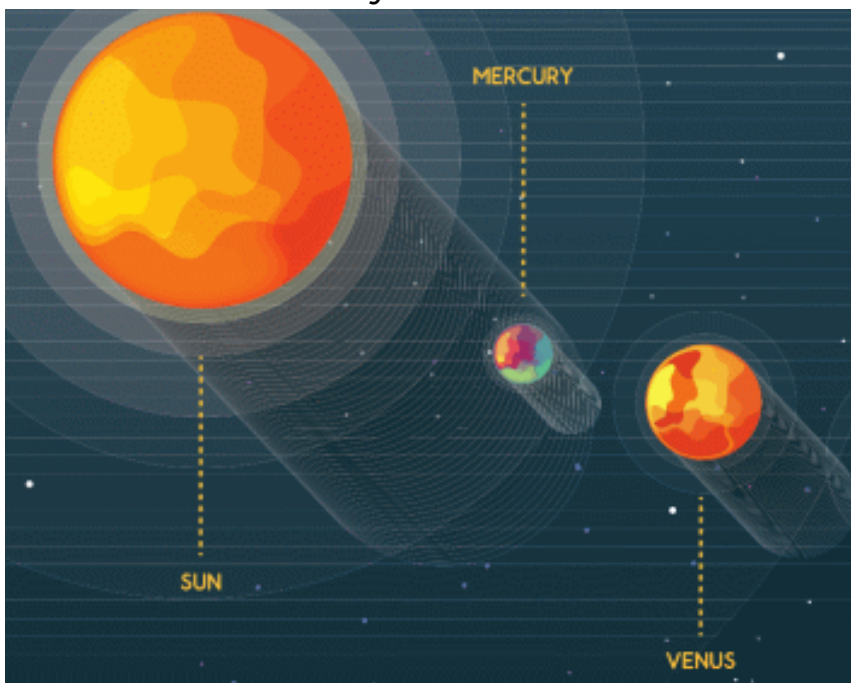

6. Train railway bars have gaps between them. Why?



7. We cannot burn wet wood. Why?



8. It is $-45\text{ }^{\circ}\text{C}$ outside, but it's $-5\text{ }^{\circ}\text{C}$ inside the igloo. Why?



CHAPTER 2

STATES OF MATTER

2.1 MELTING AND FREEZING

2.2 EVAPORATION AND CONDENSATION

2.3 GRAPHICAL ANALYSIS

2.4 HUMIDITY

LAB WORK 2

SUMMARY

PROBLEMS



2.1 MELTING AND FREEZING

YOU WILL:

- - use Molecular Kinetic Theory to describe melting and freezing;
- - apply formula of freezing / melting for problem solving.

QUESTION



Figure 1

a) Why do icicles, Figure 1, form in cold weather? How do icicles form?



Figure 2

b) Why is it dangerous to touch metal in cold weather? What may happen if you touch a metal when the weather is -30°C ? Why do people use tin, Figure 2? Is tin liquid or solid?

БАЛҚУ

Қатты денеге жылу энергиясы берілгенде, оның температурасы артады. Сол себепті, дене бөлшектерінің тербеліс қарқыны арта бастайды. Белгілі бір температурада бөлшектердің белсенді қимылдауынан кристалды құрылысы бұзылып, қатты дене сұйыққа айналады. Бұл үрдіс балқу деп аталады. Балқу кезінде молекулалар арасындағы қашықтық артып, заттың көлемі ұлғаяды. Балқудың қарапайым көрінісі Figure 3 -те көрсетілген.

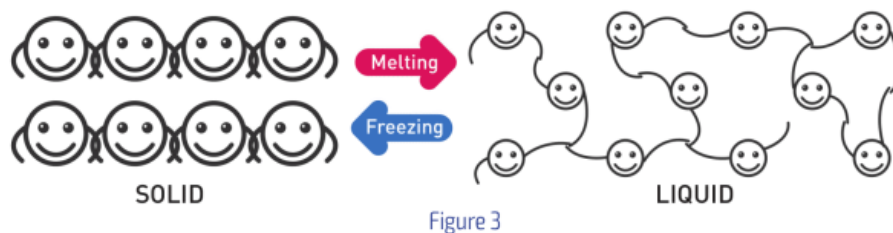

Figure 3

Кез келген қатты дененің балқуы басталатын температура - балқу температурасы деп аталады. Кейбір заттардың балқу температуралары Table 2.1-де көрсетілген.

Substance	Melting Point [0°C]	λ [J/kg°C]	Substance	Melting Point [0°C]	λ [J/kg°C]
Iron	1535.0	289 000	Ice	0	335 000
Aluminium	658.0	10 500	Lead	327.0	25 000
Benzene	5.5	126 000	Mercury	-38.9	11 400
Copper	1083.0	207 000	Silver	960.0	88 300
Ethyl alcohol	-114.4	108 000	Gold	1063.0	62 800

Table 2.1

МЕНШІКТІ БАЛҚУ ЖЫЛУЫ

Балқу температурасына жеткен затты қыздырғаннан оның температурасы өзгермейді. Себебі денеге берілетін жылудың барлығы молекулалар арасындағы байланысты әлсіретуге жұмсалады. 1 кг қатты денені балқыту үшін қажетті жылу мөлшері меншікті балқу жылуы деп аталады, ол әр затта әртүрлі болып келеді.

Мысалы:

1535°C-тағы 1 кг темірді балқыту үшін 289000 Дж керек.

960°C-тағы 1 кг күмісті балқыту үшін 88300 Дж керек екен.

Басқа да мысалдарды Table 2.1 -ден көре аласыз.

The formula for melting:

$$Q = m \times \lambda$$

Q	=	m	×	λ
heat (Joules, J)		mass (Kilograms, kg)		specific latent heat of fusion (Joule/kilogram, J/kg)

ҚАТУ

Балқу температурасындағы сұйық денені суытсақ, ол қата бастайды. Өйткені, бөлшектердің кинетикалық энергиялары азайып, қозғалыстары баяулайды. Нәтижесінде, бөлшектер кристалды қалпына қайта оралады. Бұл дененің қату процесі деп аталады. Қату процесі балқудың кері процесі болып табылады. Қату температурасы балқу температурасына тең болып келеді. Сол себепті, меншікті балқу жылуы меншікті қату жылуына тең.

EXAMPLE

Calculate the energy needed to melt 2 kg of ice at 0 °C. Use Table 2.1

Solutions:

$$m = 2 \text{ kg}$$

$$\lambda = 335 \text{ kJ/kg}$$

Formula:

$$Q = m \times \lambda$$

Calculation:

$$Q = 2 \times 335\,000 = 670\,000 \text{ J} = 670 \text{ kJ}$$

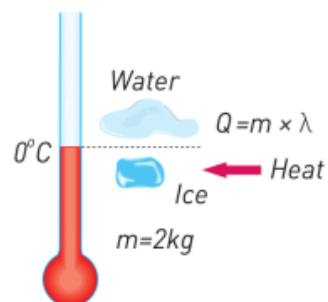

EXAMPLE

100 g of water is at 40 °C. How much heat must water lose to become ice at 0 °C?

Solution:

First, water must lose heat to reach freezing point:

$$Q_1 = m \times c \times \Delta T$$

$$Q_1 = 0.1 \text{ kg} \times 4200 \frac{\text{J}}{\text{kg}^\circ\text{C}} \times [40^\circ\text{C} - 0^\circ\text{C}]$$

$$Q_1 = 16\,800 \text{ J}$$

Then, water freezes and loses more heat:

$$Q_2 = m \times \lambda$$

$$Q_2 = 0.1 \text{ kg} \times 335\,000 \frac{\text{J}}{\text{kg}}$$

$$Q_2 = 33\,500 \text{ J}$$

Total heat lost by water: $16\,800 \text{ J} + 33\,500 \text{ J} = 50\,300 \text{ J}$

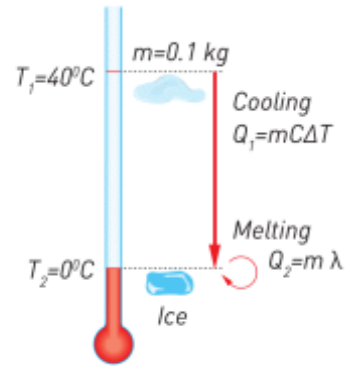

FACT

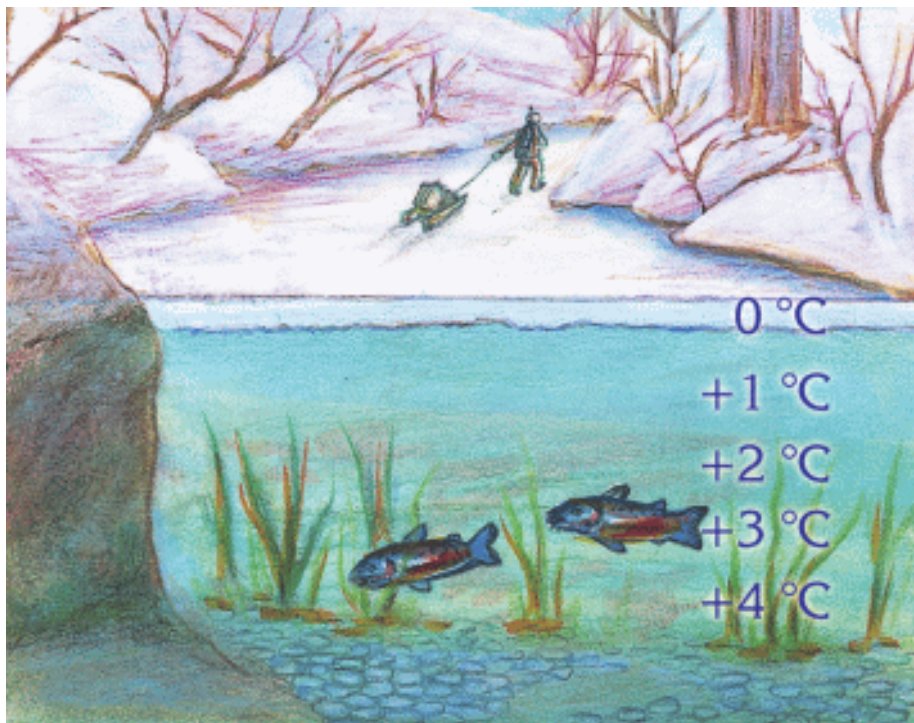

When water freezes, it becomes bigger. The density becomes smaller. This is why ice is on the top of the water. The ice protects living things from cold.

FACT

Sometimes hot water freezes faster than cold water. It is called “Mpemba effect”.

LITERACY

1. Ауа райының температурасы 0°C -тан төмен. Осы кезде жаңбыр әлде қар жауа ма? Не себепті?
2. Температурасы 0°C , массасы 1 кг мұзды еріту үшін қанша Джоуль жылу қажет? Және осы мұзды еріту үшін қанша килограмм ыстық су (100°C) қажет?
3. Температурасы -1°C , массасы 1 кг мұзды еріту үшін қанша Джоуль энергия қажет? Неге сіздің жауабыңыз 2-сұрақтың жауабымен сәйкес келмейді?
4. Кейбір тауларда жазда да қар жатады. Не себепті?
5. Ауа-райының температурасы -25°C суық. Біраздан соң қар жауады. Қар жауғаны үшін температура -18°C -қа дейін көтеріледі. Не себепті?

ART TIME

How would you design a dance that shows “melting and freezing”. Show the dance to your parents, teachers and friends.

TERMINOLOGY

- melting – балқу / плавление
- freezing – қату / замораживание
- bond – байланыс / связь
- copper – мыс / медь
- contraction – қысқару / уменьшение
- opposite – қарама-қарсы / противоположный

2.2 EVAPORATION AND CONDENSATION

YOU WILL:

- - use Molecular Kinetic Theory to describe boiling and condensation;
- - analyse temperature-time graph of boiling and condensation.

QUESTION

Why do bubbles form at the bottom of the pan? Why do bubbles not form at the top?

БУЛАНУ

Сұйықтықтың молекулаларының жылдамдықтары әртүрлі болады. Кинетикалық энергиясы жоғары молекулалар сұйық бетінен ұшып шыға бастайды. Сұйық газ тәрізді күйге айнала бастайды. Бұл құбылыс булану деп аталады, Figure 1 а. Булану процесі кез-келген температурада жүре береді. Оған дәлел, ылғал киімдер салқын немесе бұлтты күндерде де кебеді.



Figure 1

Сұйық температурасы артқан сайын, булану процесінің қарқындығы да артады. Белгілі температурада булану қарқыны өзінің максималды дәрежесіне жетеді. Басқа сөзбен айтқанда, сұйық қайнай бастайды, Figure 1 b. Сұйық қайнаған кезде температурасы тұрақты болады, әрі булану максималды деңгейіне жетеді.

Мысалы, су максималды булану деңгейіне 100°C-та жетеді. Демек бұл оның қайнау температурасы. Table 2.2-де түрлі заттардың қайнау температуралары келтірілген.

Substance	Boiling Point (°C)	r (J/kg)
Ethyl alcohol	78	853 000
Bromine	60	180 000
Lead	1170	732 000
Lithium	1336	2 136 000
Mercury	358	297 000
Nitrogen	-196	201 000
Oxygen	-183	213 000
Sulphuric acid	326	510 000
Water	100	2 260 000
Zinc	918	1 986 000

Table 2.2

МЕНШІКТІ БУЛАНУ ЖЫЛУЫ

Қайнау температурасына жеткен сұйықты қыздырғанда, оның температурасы өзгермейді. Себебі, сұйыққа берілген жылу энергиясың барлығы молекулалар арасындағы байланысты үзуге жұмсалады. Нәтижесінде, сұйық газға айнала бастайды, Figure 2.

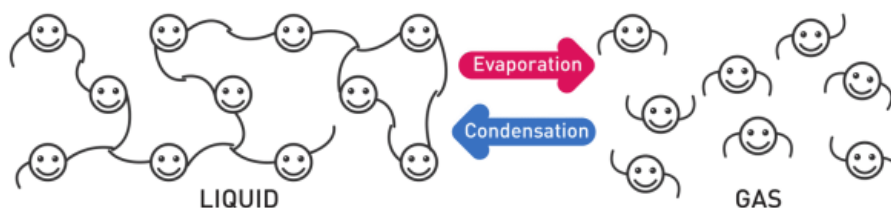

Figure 2

Қайнау температурасында 1 кг сұйықты буға айналдыруға кететін жылу мөлшері меншікті булану жылуы деп аталады.

Мысалы:

100°C-тағы 1 кг суды буландыру үшін 2260000 Дж жылу керек.

1170°C-тағы 1 кг қорғасынды газға айналдыру үшін 732000 Дж жылу керек. Басқа да мысалдарды Table 2.2-ден көре аласыздар.

Substance	Boiling Point (°C)	r (J/kg)
Ethyl alcohol	78	853 000
Bromine	60	180 000
Lead	1170	732 000
Lithium	1336	2 136 000
Mercury	358	297 000
Nitrogen	-196	201 000
Oxygen	-183	213 000
Sulphuric acid	326	510 000
Water	100	2 260 000
Zinc	918	1 986 000

Table 2.2

Сұйықтықты буландыруға қажетті жылуды есептеу теңдеуі:

$$Q = m \times r$$

Q	=	m	\times	ρ
heat		mass		specific heat of vapourisation
(Joules, J)		(kilograms, kg)		(Joule/kilogram, J/kg)

КОНДЕНСАЦИЯ

Егер де газды салқындататын болсақ, газ молекулалардың жылдамдықтары кеміп, олардың кинетикалық энергиялары азаяды.

Газ молекулаларының арақашықтары азая бастайды. Өзара жақындасудың нәтижесінде газ сұйыққа айнала бастайды. Бұл құбылыс конденсация деп аталады. Конденсация булануға қарамақарсы үрдіс. Сондықтан да, конденсация қайнау температурасында орын алады, Figure 3.

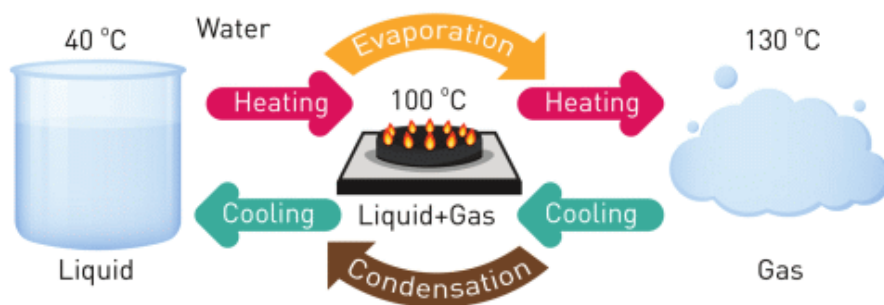

Figure 3

EXAMPLE

Calculate the energy required to convert 500 g of water at 80 °C to steam at 100 °C.

Solution:

1. Energy to heat water

$$Q = m \times c \times \Delta T$$

$$Q_1 = 0.5 \times 4200 \times (100 - 80)$$

$$Q_1 = 42\,000 \text{ J}$$

2. Energy to boil water $Q = m \times r$

$$Q_2 = 0.5 \times 2\,260\,000$$

$$Q_2 = 1\,130\,000 \text{ J}$$

$$\text{Total energy: } Q_{\text{total}} = 42\,000 \text{ J} + 1\,130\,000 \text{ J} = 1\,172\,000 \text{ J}$$

EXAMPLE

Температурасы 120°C, массасы 100 г судың буы бар.
Температурасы 70°C суға айналдыру үшін қанша энергия сыртқа бөлінуі керек?

Solution:

1. Vapour cools to 100 °C

$$Q_1 = m \times c \times \Delta T_1, \quad c_{\text{water vapour}} = 2100 \text{ J/kg}^\circ\text{C}$$

$$\Delta T_1 = 120 \text{ }^\circ\text{C} - 100 \text{ }^\circ\text{C} = 20 \text{ }^\circ\text{C}$$

$$Q_1 = 0.1 \text{ kg} \times 2100 \text{ J/kg}^\circ\text{C} \times 20 \text{ }^\circ\text{C} = 4200 \text{ J}$$

2. Condensation of water vapour.

$$Q_2 = m \times r = 0.1 \text{ kg} \times 2\,260\,000 \text{ J/kg} = 226\,000 \text{ J}$$

3. Water cools to 70 °C.

$$Q_3 = m \times c \times \Delta T_2$$

$$\Delta T_2 = 100 \text{ }^\circ\text{C} - 70 \text{ }^\circ\text{C} = 30 \text{ }^\circ\text{C}$$

$$Q_3 = 0.1 \text{ kg} \times 4200 \text{ J/kg}^\circ\text{C} \times 30 \text{ }^\circ\text{C} = 12\,600 \text{ J}$$

Total energy lost:

$$Q_{\text{total}} = Q_1 + Q_2 + Q_3 = 4200 \text{ J} + 226\,000 \text{ J} + 12\,600 \text{ J} = 242\,800 \text{ J}$$

ФАКТ



If you take a very cold bottle and leave it for several minutes, the surface of the bottle will become wet. This is because air contains water molecules. These molecules condense because temperature around the bottle is lower.

FACT

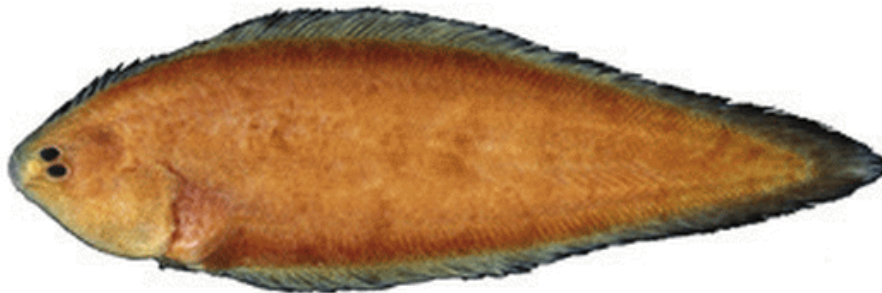

Кейбір балықтар суасты жанартаулар қасында өмір сүре алады. Ол жерде температура 180°C -қа дейін жетеді.

RESEARCH TIME

Take two identical bottles and fill them with water. Wrap one of them with wet paper. Then put them to a cold place. After about 40 minutes measure the temperatures of water in the bottles. Why are temperatures different (or same)?

LITERACY

1. Why do clouds form? How do clouds form?

2.

You heat mass of	from	to	How many Joules do you need?
1 kg	100°C water	100°C vapour	
1 kg	99°C water	100°C vapour	
1 kg	100°C water	101°C vapour	

3. Why are answers in question 2 different?

4. Find same substances in Table 2.1 and Table 2.2. Compare their (λ) and (r). Why (r) is always greater?

TERMINOLOGY

- boiling – қайнау / кипение
- to escape – шығу / сбегать
- melted – еріген / расплавленный
- habitat – мекендеу ортасы / среда обитания

2.3 GRAPHICAL ANALYSIS

YOU WILL:

- - analyse temperature-time graph of melting and freezing;
- -analyse temperature-time graph of boiling and condensation.

GRAPHICAL ANALYSIS

Look at the graph below. What can you say about it?

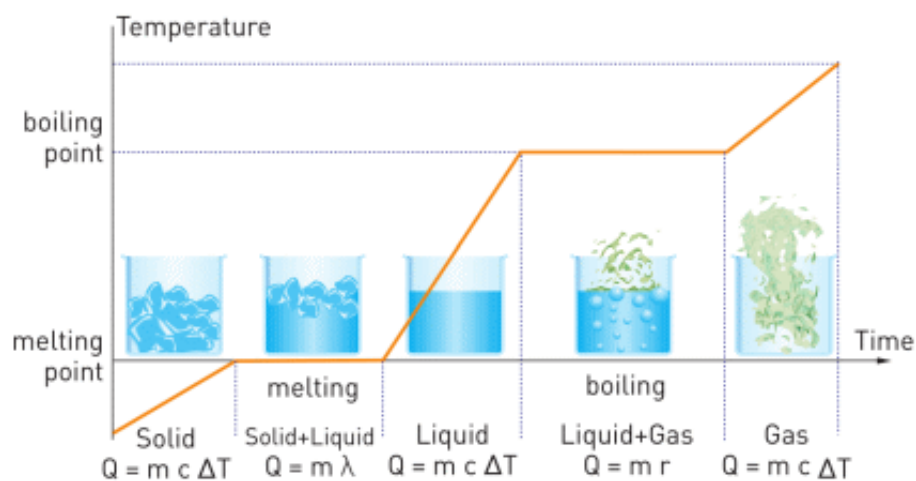

1. How many joules do you need to melt 1 kg of ice at 0°C?
How many kg of water at 100°C do you need to melt 1 kg of ice at 0°C?

Answer:

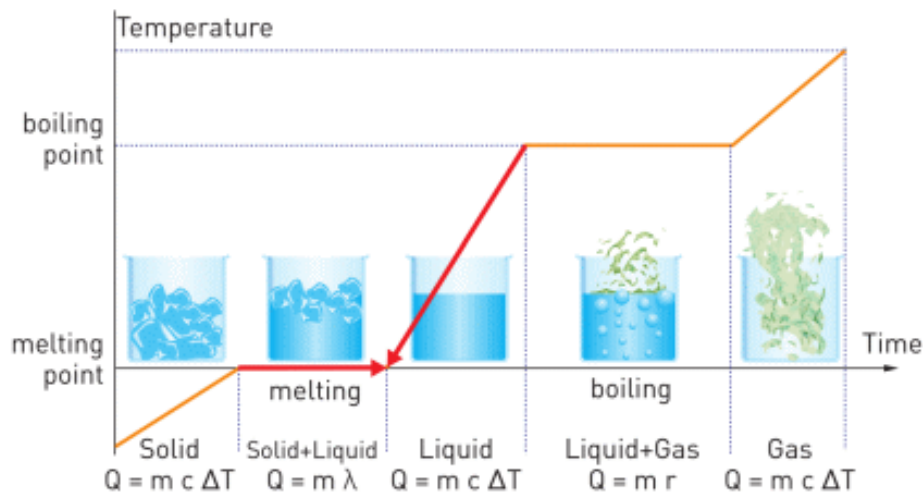

Ice has $T_{\text{initial}} = 0^{\circ}\text{C}$, and it must have $T_{\text{final}} = 0^{\circ}\text{C}$. Water has $T_{\text{initial}} = 100^{\circ}\text{C}$, it must have $T_{\text{final}} = 0^{\circ}\text{C}$. At the end there is water at 0°C . Water gives heat and gains that heat.

Heat gained by ice:

$$Q = m \lambda = 1 \text{ kg} \times 335000 \text{ J/kg} = 335000 \text{ Joules}$$

Heat lost by water:

$$Q_{\text{lost}} = - m c \Delta T = - m \times 4200 \text{ J/kg}^{\circ}\text{C} \times (-100^{\circ}\text{C}) = 420000 \times m$$

Heats must be equal: $335000 = 420000 \times m$

$$m = 0.798 \text{ kg of water} = 798 \text{ grams of water}$$

2. How many Joules do you need to melt 1 kg of ice at -1°C ? Why is your answer different from answer in question 2?

Answer:

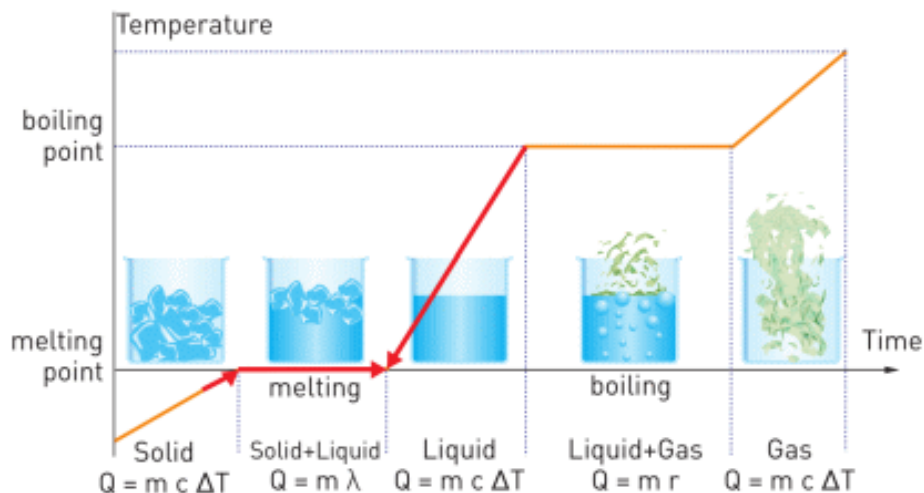

3. Ice has $T_{\text{initial}} = -1^{\circ}\text{C}$ and $T_{\text{final}} = 0^{\circ}\text{C}$. Water has $T_{\text{initial}} = 100^{\circ}\text{C}$ and $T_{\text{final}} = 0^{\circ}\text{C}$. At the end there is water at 0°C . Water gives heat and ice takes heat.

Heat gained by ice: $Q = m c \Delta T + m \lambda$

$Q = 1 \text{ kg} \times 2100 \text{ J/kg}^{\circ}\text{C} \times 1^{\circ}\text{C} + 1 \text{ kg} \times 335000 \text{ J/kg} = 337100$
Joules

Heat given by water:

$Q = m c \Delta T = m \times 4200 \text{ J/kg}^{\circ}\text{C} \times 100^{\circ}\text{C} = 420000 \times m$

Heats are equal:

$337100 = 420000 \times m$

$m = 0.803 \text{ kg of water} = 803 \text{ grams of water}$

In question 1 the answer is 798 grams. In question 2 the answer is 803 grams. In question 2, firstly we heat ice from -1°C to 0°C . Then, we melt the ice. That's why answers are different.

4. How many joules do you need to change 1 kg of water at 100°C into vapour at 100°C?

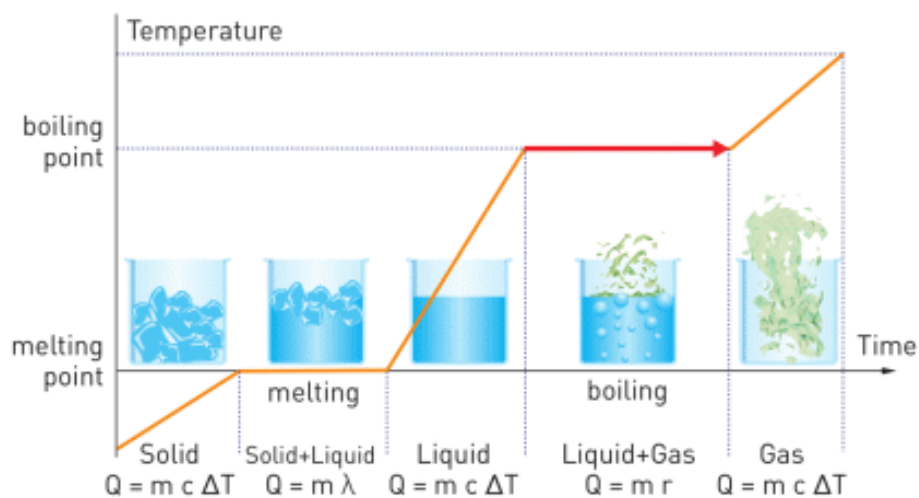

To boil water:

$$Q = m r = 1 \text{ kg} \times 2260000 \text{ J/kg} = 2260000 \text{ Joules}$$

5. How many joules do you need to change 1 kg of water at 99°C into vapour at 100°C?

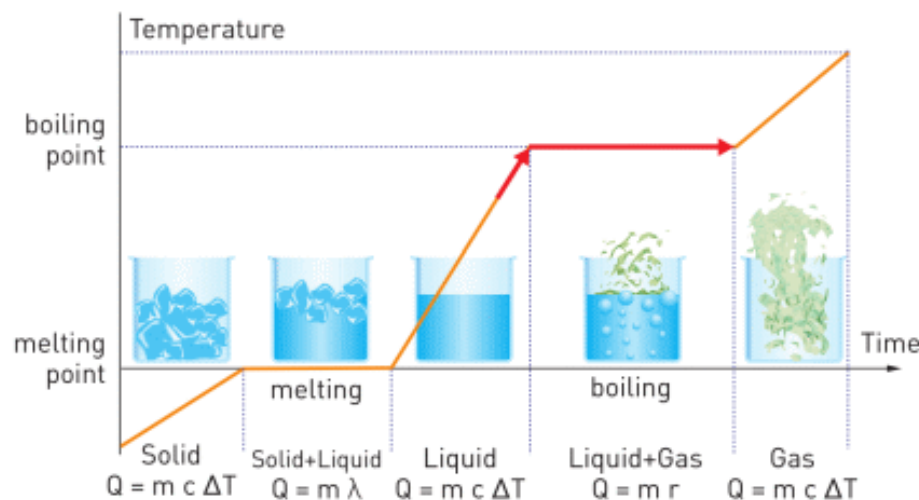

We heat water and then boil it.

$$Q = m c \Delta T + m r = 1 \text{ kg} \times 4200 \text{ J/kg}^\circ\text{C} \times 1^\circ\text{C} + 1 \text{ kg} \times 2260000 \text{ J/kg} = 2264200 \text{ Joules}$$

6. How many joules do you need to change 1 kg of water at 100°C into vapour at 101°C?

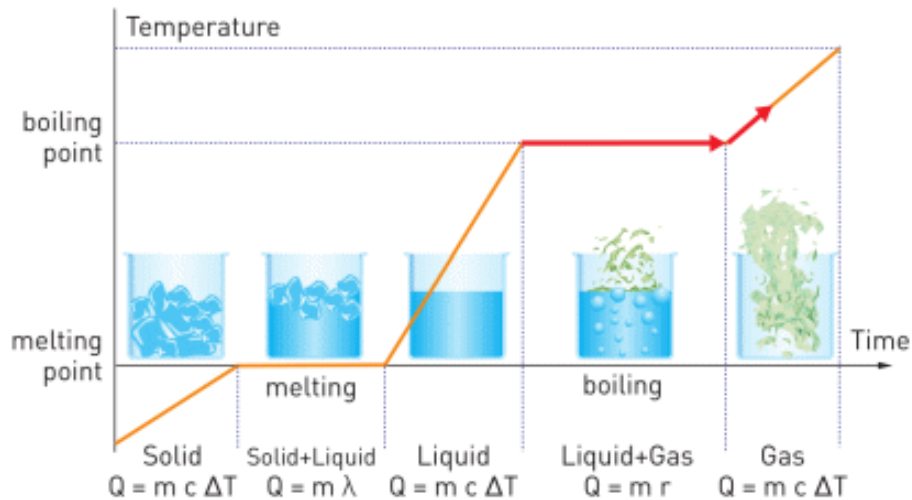

First, we boil water. Then, we heat vapour.

$$Q = m r + m c \Delta T = 1 \text{ kg} \times 2260000 \text{ J/kg} + 1 \text{ kg} \times 2100 \text{ J/kg}^\circ\text{C} \times 1^\circ\text{C} = 2262100 \text{ Joules}$$

ACTIVITY

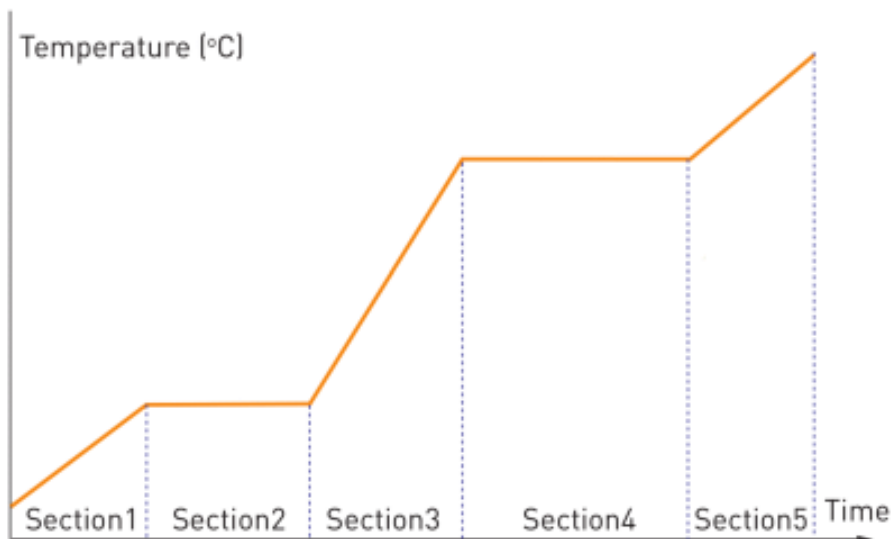

a) If you draw graphs for these substances, which sections each graph will have? Put ticks in boxes.

	section 1	section 2	section 3	section 4	section 5
Ice, from -15 °C to water 25 °C					
Lead, from 250 °C to 40 °C					
Gold, from 1200 °C to 1850 °C					
Nitrogen, from -300 °C to -150 °C					
Mercury, from 30 °C to 350 °C					
Lithium, from 1500 °C to 300 °C					
Bromine, from 40 °C to 70 °C					
Alcohol, from 80 °C to - 50 °C					

b) Each substance has a mass of 2 kg. Choose 4 of them and calculate total heat in each case.

Use Table 2.1, Table 2.2, Table 1.5 and internet.

2.4 HUMIDITY

YOU WILL:

- - determine amount of heat during boiling;
- - explain the dependence of boiling point on external pressure.

QUESTION



Sometimes wet clothes dry out in 1 hour. However, sometimes they can be still wet even after several hours. How would you explain this?

ЫЛҒАЛДЫЛЫҚ

Ауаның құрамында су молекулалары (бу) бар. Себебі, теңіз, көл, өзендердегі су әрдайым булануда, Figure 1.

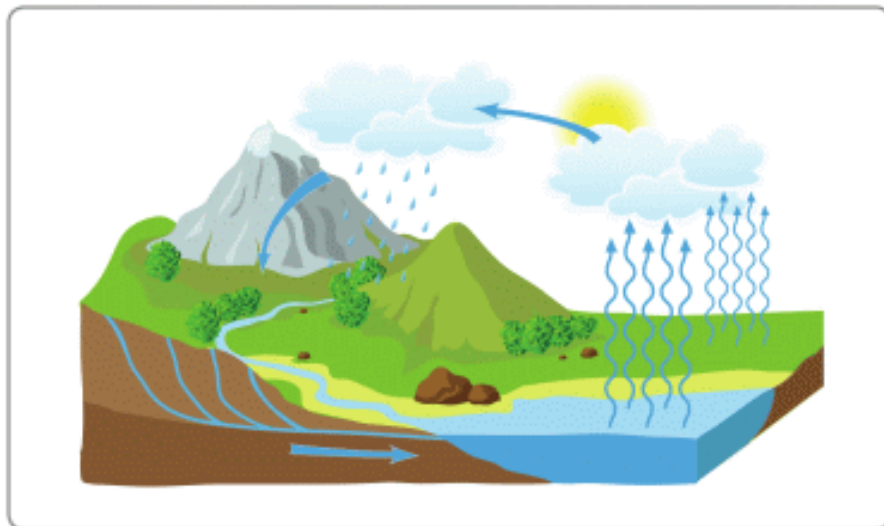

Figure 1

Булану процесі кез келген температурада жүреді. Бөлмеде стаканға су құйылса, белгілі уақыттан кейін, стакандағы су буланып кетеді. Нәтижесінде бөлмедегі ауада су молекулаларының саны артады. Ал, бұл құбылыс ылғалдылыққа әсер етеді, дәлірек айтқанда арттырады.

Ылғалдылық ауадағы су молекулаларының мөлшерін білдіреді.

Мысалы, егер ылғалдылық 11 г/м^3 болса, демек әр метр куб кеңістікте 11 г су бар. Ылғалдылық үшін тығыздықтың өлшем бірлігі қолданылады.

Алайда, ауаның сыйымдылығы шектеулі. Figure 2-дегідей стаканның бетін жауып қойсақ, біраз уақыттан соң судың буланғанын байқаймыз.

Су үстіндегі ауа толық ылғалданған кезде су булануын тоқтатады. Осы жағдайда, яғни ылғалдылық максимум болғандағы бу қаныққан бу деп аталады.

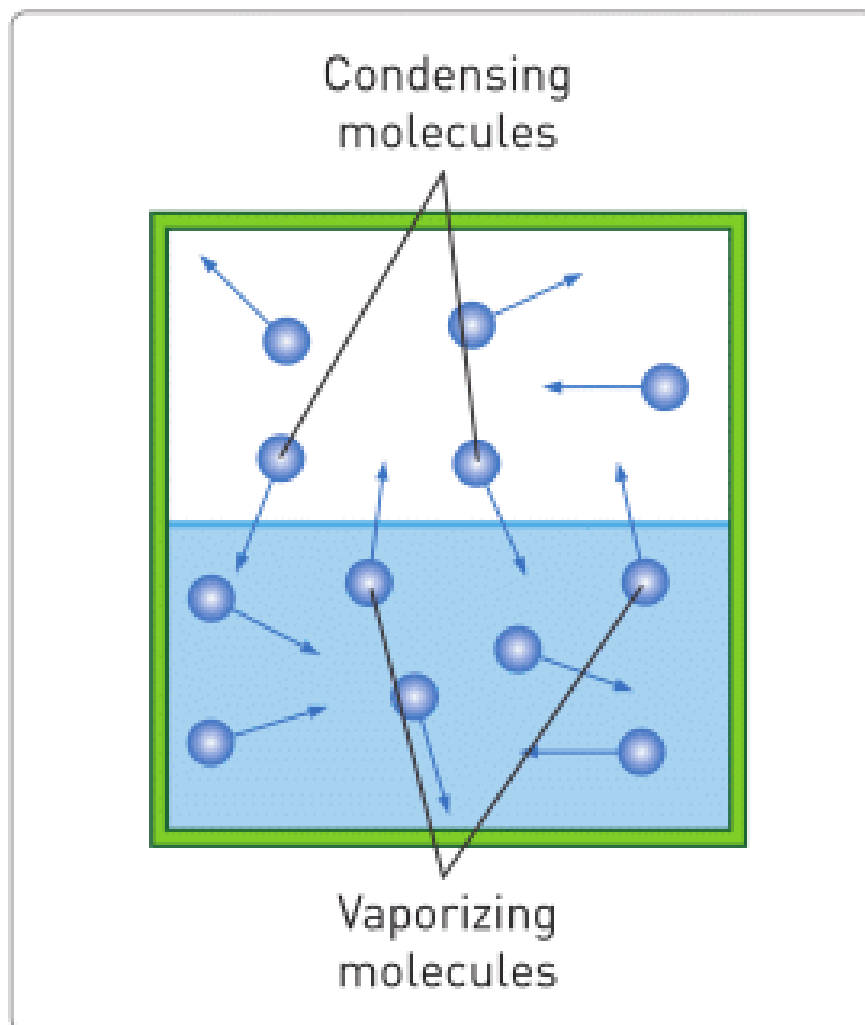

Figure 2

ЫЛҒАЛДЫЛЫҚ ЖӘНЕ ТЕМПЕРАТУРА

Ылғалдылықтың максималды болуы ауа температурасына байланысты. Мысалы, ауа температурасы 20°C болса, ылғалдылық 17.15 г/м^3 болады. Ал, 35°C -та ылғалдылық 39.30 г/м^3 . Table 2.4 -де басқа да мысалдарды көруге болады.

Temperature (°C)	Maximum humidity (g/m ³)
100	588.21
40	50.67
30	30.08
20	17.15
10	9.36
0	4.87
-10	2.16
-30	0.33
-50	0.04
-90	0.0001

Table 2.4

ҚАЙНАУ ЖӘНЕ АУА ҚЫСЫМЫ

Алдыңғы сабақтардан, су 100°C-та қайнайтынын білеміз. Бірақ қайнау температурасы ауа қысымына да байланысты екенін естіген шығарсыздар. Егер, біз 7000 м биіктікте суды қыздырсақ, ол 70°C-та қайнайды, Figure 3. Осыдан, судың айналасындағы ауа қысымы азайса, оның қайнау температурасы төмендей түседі деген қорытындыға келеміз.

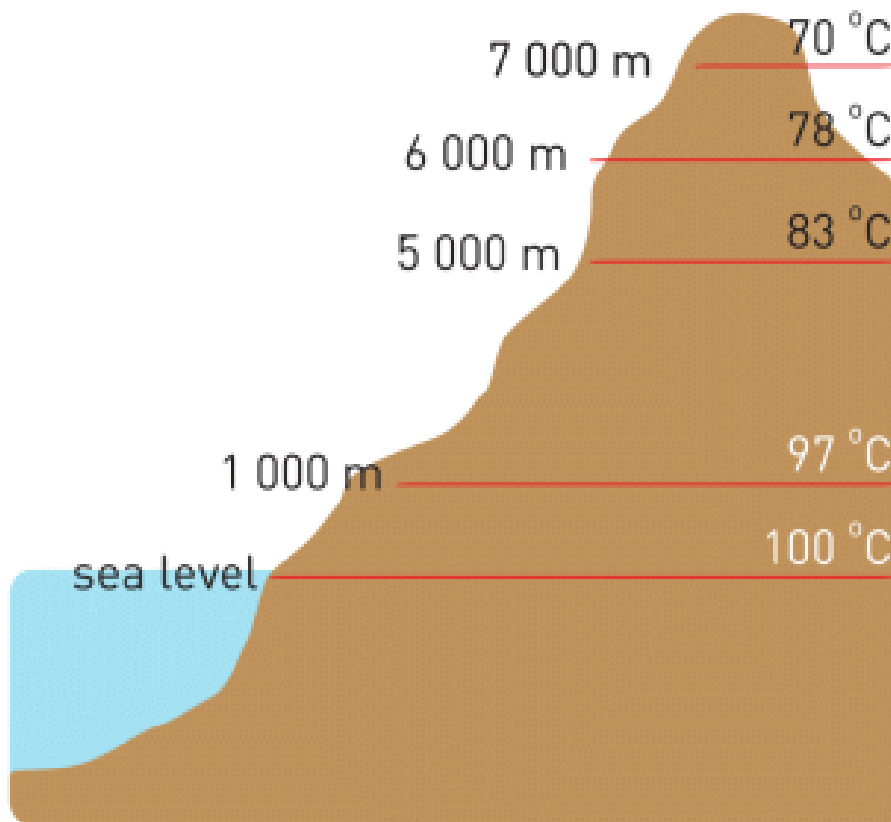

Figure 3

Дәл солай, ауа қысымы артқан сайын, сұйықтың қайнау температурасы да арта түседі. Бұл қасиет тамақ дайындауда қолданылады, Figure 4. Мысалы, етті қазанда пісіру үшін 2-3 сағат кететін болса, Figure 4-тегі көрсетілген қысыммен пісірілетін қазанда 1 сағатта піседі. Дегенмен, мұндай ыдысты қолданғанда абай болу керек.



Figure 4

RESEARCH TIME

Бірдей екі шыны немесе пластик стакан алыңыз. Стаканның жартысын ыстық сумен толтырыңыз (абай болыңыз).

Ыстық суы бар стаканның үстіне бос стаканды орналастырыңыз. 3-4 минуттай бақылаңыз.

а) Не байқадыңыз? Себебін түсіндіріңіз.

ә) Стаканның үстіне мұз кесектерін қойсаңыз не болады?
Себебін түсіндіріңіз



EXAMPLE

The container of 20 m^3 is at $40 \text{ }^\circ\text{C}$. The container contains saturated water vapour. How much water will condense if we decrease temperature till $0 \text{ }^\circ\text{C}$?

Solutions:

1. The maximum amount of water at 40°C is:

$$50.67 \text{ g/m}^3 \times 20 \text{ m}^3 = 1013.4 \text{ g}$$

2. The maximum amount of water at $0 \text{ }^\circ\text{C}$ is:

$$4.87 \text{ g/m}^3 \times 20 \text{ m}^3 = 97.4 \text{ g}$$

3. Temperature decreases, and then the amount of water in air decreases.

Therefore, $1013.4 \text{ g} - 97.4 \text{ g} = 916 \text{ g}$ of water will condense.

ACTIVITY

Look at Table 2.4.

It is clear that the "capacity" of air increases as the temperature becomes higher.

a) Construct your theory that can explain this.

b) What if the "capacity" of air would decrease with the temperature of the air? How would it change the world?

FACT

A camel can live without water for about 35 days. The source of water is not its hump. Camel can take water from the air. This is the property of camel's nose.

ART TIME

Produce and perform a dance that explains "saturated and unsaturated vapour". Show the dance to your parents, teachers and friends.

LITERACY

1. Бірдей температура болса да, ылғалды жер (джунгли) не себепті шөл (сахара) жерден ыстық болып сезіледі?
2. Оңтүстік полюстегі адамдар не үшін 15-20 минуттан артық жұмыс істей алмайды?

3. Ауаның ылғалдылығы кешке 15 г/м^3 , ал таңертең 10 г/м^3 болса, көлемі 40 м^3 бөлмеде қанша су конденсацияланады?
4. Теңіздер, мұхиттар және көлдер әрдайым буланып жатады. Не үшін олар құрғап кетпейді?
5. Figure 5-тегі құрал не үшін деп ойлайсыз?

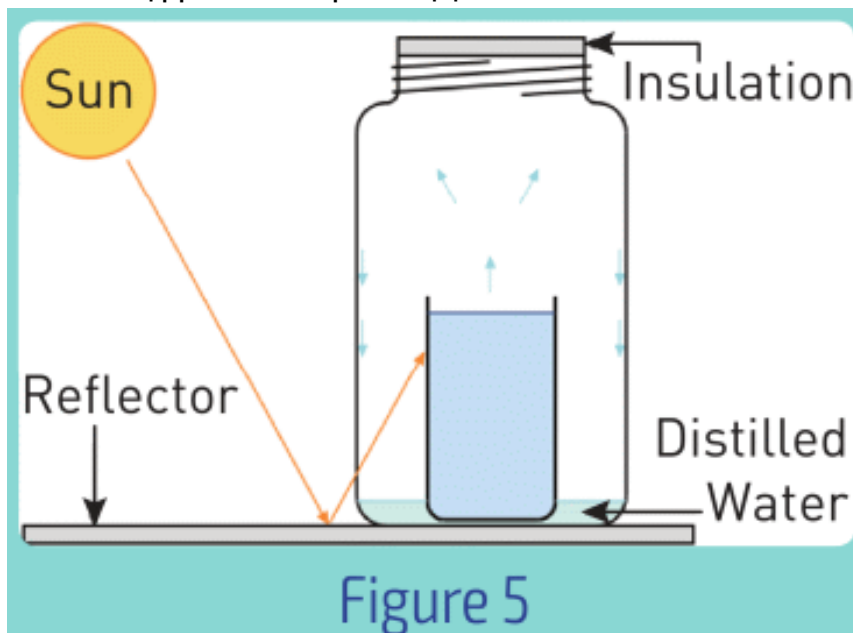

6. Бір шыны суды космоста ашса, не болуы мүмкін?
7. Қысымы үлкен ыдыста тамақ неліктен тезірек піседі? Не себепті ол қауіпті?

TERMINOLOGY

- evaporation - булану / испарение
- humidity - ылғалдылық / влажность
- dry - құрғақ / сухой
- saturated vapour - қаныққан бу / насыщенный пар

LABWORK 2

TITLE:

Latent heat of fusion

OBJECTIVES:

- To measure initial temperature of ice and a final temperature of the ice-water mixture.
- To apply the specific heat capacity equation for calorimetry and equation for melting to calculate the latent heat of fusion of ice.

MATERIALS LIST:

1. calorimeter
2. hot water
3. beaker
4. electronic (or mechanical) scales
5. thermometer
6. hot plate
7. stirring rod
8. ice



SAFETY:

1. When using a burner or hot plate, always wear goggles and an apron to protect your eyes and clothing. Tie back long hair, secure loose clothing, and remove loose jewellery. In a case of emergency, call a teacher.
2. Never leave a hot plate unattended while it is turned on.
3. If a thermometer breaks, notify the teacher immediately.
4. Do not heat glassware that is broken, chipped, or cracked. Use tongs or a mitt to handle heated glassware and other equipment because it does not always look hot when it actually is.
5. Allow all equipment to cool before storing it.

6. Never put broken glass or ceramics in a regular waste container. Use a dustpan, brush, and heavy gloves to carefully pick up broken pieces and dispose of them in a container specifically provided for this purpose.

THEORY:

$$Q = m \times c \times \Delta T$$

$$Q_{\text{given}} = Q_{\text{taken}}$$

$$Q = m \times L_{\text{fusion}}$$

$$Q = m \times c \times \Delta T$$

$$Q_{\text{given}} = Q_{\text{taken}}$$

$$Q = m \times \lambda$$

- What is Q? What is the unit of measurement of Q?
- What is m? What is the unit of measurement of m?
- What is c? What is the unit of measurement of c?
- What is ΔT ? What is the unit of measurement of ΔT ?
- What is λ ? What is the unit of measurement of λ ?

PROCEDURE:

1. Read the entire lab procedure, and plan the steps you will take. Determine which steps can be performed while you are waiting for the water to heat.
2. Record your data in the data table.
3. Choose a location where you can set up the experiment away from the edge of the table and from other groups. Make sure the switch of the hot plate is in the “off” position before you plug it in.
4. Turn on the hot plate and adjust the heating control to heat the water.
5. Use the thermometer to measure the temperature of the hot water. (Note: When making temperature readings, take care not to touch the hot plate and the water.)
6. Use the scales to measure the mass of the hot water and ice.
7. Use the stirring rod to gently stir the mixture of hot water and ice in the calorimeter. Do not use the thermometer to stir the water.
8. Measure temperature of the mixture.
9. If ice remains to pour water into the sink (but not ice).
10. Measure the final mass of ice.
11. Clean up your work area. Put equipment away safely so that it is ready to be used again.

ANALYSIS:

1. Measure the final temperature of the mixture.
2. Calculate the energy transferred to the ice.
3. Calculate the energy transferred from the hot water.
4. Determine latent heat of fusion of ice.

CONCLUSIONS:

1. Explain why the energy transferred as heat to the ice is equal to the energy transferred as heat from the hot water.
2. Explain why theoretical and experimental values of latent heat of fusion of ice are different.
3. How would your results be affected if the initial mass of the ice is much bigger than the mass of hot water?
4. What is the purpose of the calorimeter in this experiment?

SUMMARY

- Melting: When bonds between molecules and atoms become weaker.



- Every solid melts at a certain temperature - melting point.
- The energy needed to melt 1 kg of solid substance is called specific latent heat of fusion (λ), and it depends on the type of the substance.
- The formula for melting:

$$Q = m \times \lambda$$

heat (Joules, J) mass (kilograms, kg) specific latent heat of fusion (Joule/kilogram, J/kg)

- $Q = m \times \lambda$
- Q - heat. Unit: [J]
- m - mass of a substance. Unit: [kg]
- λ - specific latent heat of fusion. Unit: [J/kg]
- Freezing is opposite process of melting.
- That's why we can use specific heat of fusion (λ) for melting and freezing.
- Particles with higher kinetic energy sometimes can escape from the liquid. Escaped particles turn into gas. This is called evaporation.
- When we heat a liquid, the liquid can reach the temperature of maximum and evaporation rate, it's called boiling.

- The temperature of maximum evaporation rate is called boiling point.

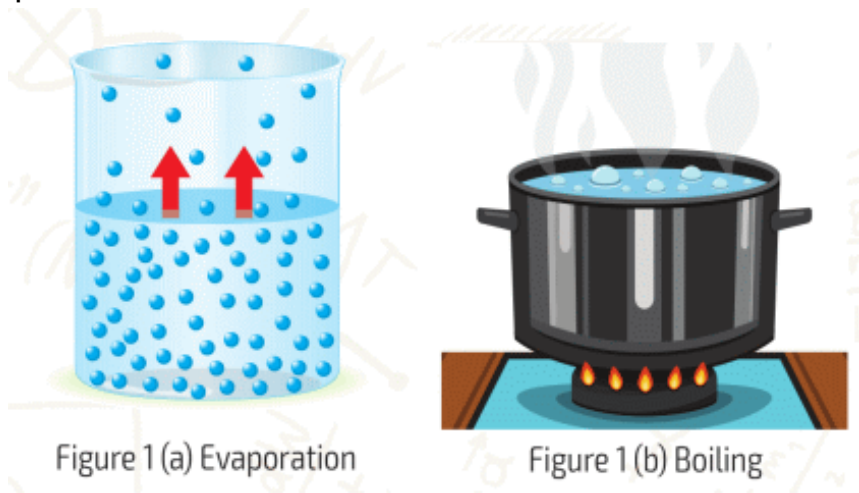

- When a liquid gets heat at boiling point, bonds between particles break.
- The energy needed to boil 1 kg of a liquid is called specific latent heat of evaporation (r).

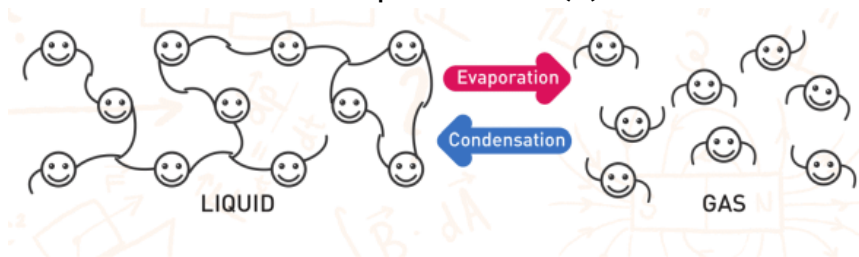

- The formula of energy needed to evaporate or boil a liquid:

$$Q = m \times r$$

heat (joules, J) = mass (kilograms, kg) × specific heat of vaporization (joule/kilogram, J/kg)

- $Q = m \times r$
- Q - heat. Unit: [J]
- m - mass of a substance. Unit: [kg]
- r - the specific latent heat of evaporation. Unit: [J/kg]
- Condensation is opposite of boiling.

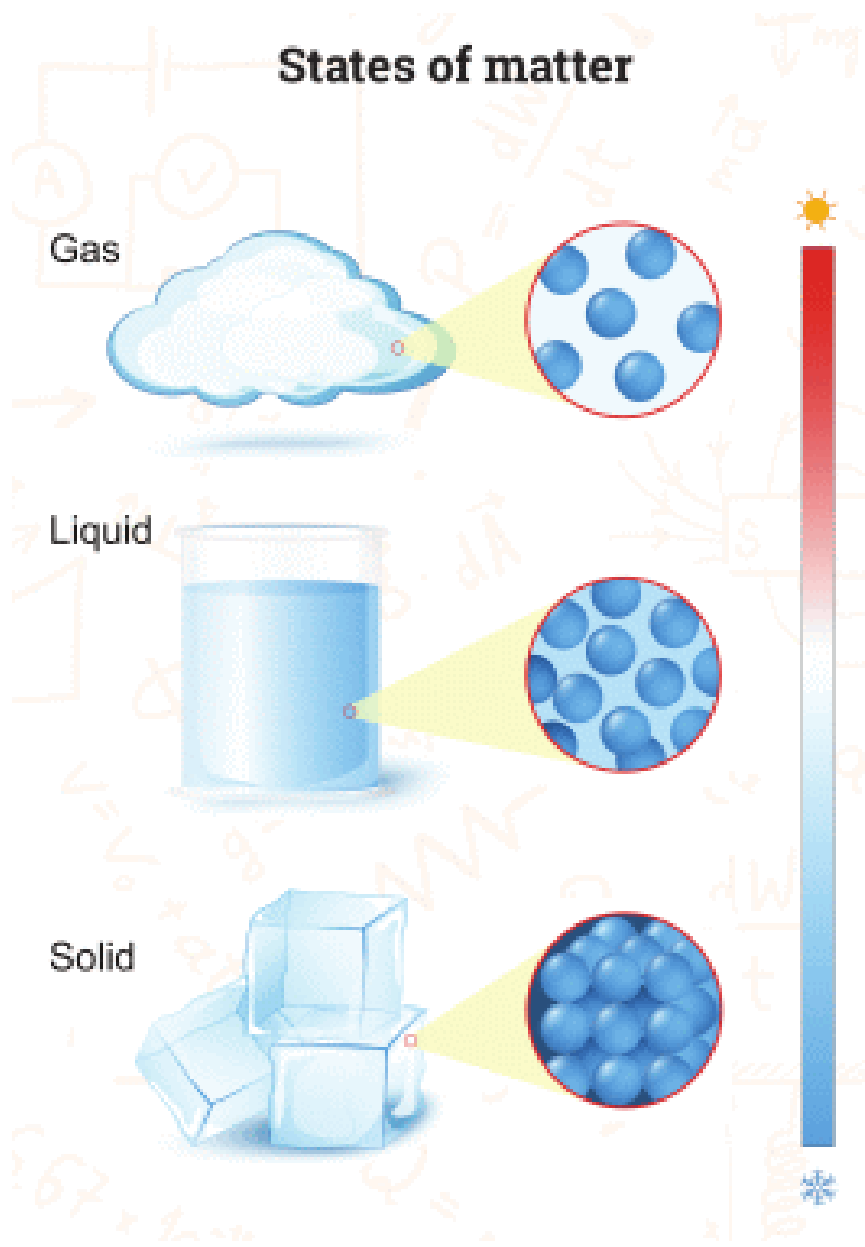

PROBLEMS

FILL IN THE BLANKS WITH APPROPRIATE WORDS.

1. ΔT is the difference between the and..... temperatures.
2. The unit of heat energy in SI units is
3. The unit is widely used to measure the energy of foods.
4. 1 joule is the required to raise the temperature of 1 kg of pure by 1°C .
5. The is the change in state of matter from liquid to solid.
6. The is the temperature at which boiling occurs.
7. If a solid is dissolved in a liquid, the liquid freezes at a temperature.
8. When a liquid evaporates, it energy from its surrounding; as a result the surroundings..... .

ANSWER THE QUESTIONS

1. What does the temperature change of matter depend on?

2. Does a substance that heats up quickly have a high or low specific heat capacity?
3. Which one warms up faster when heated, iron or silver?
4. Explain the structure of a calorimeter and how it is used.
5. Desert sand is very hot in the daytime and very cool in the night-time. What does this tell you about its specific heat?
6. Explain the atomic structures of solids, liquids and gases.
7. What is the process of melting?
8. What factors affect the melting point of ice?
9. Explain the process of freezing.
10. In what ways is the expansion of water different from other liquids?
11. Why does ice form at the surface of water but not at the bottom?
12. Explain why do people tend to feel hot and uncomfortable on a humid day.
13. Why is it important to protect water pipes from freezing?
14. What is the specific latent heat of fusion?
15. What is the process of boiling?
16. What is the difference between the processes of boiling and vaporisation?
17. Give two ways in which the boiling point of a liquid can be raised.

18. Explain why in a warm room condensation forms on a cold window.

19. How does a refrigerator work?

20. What are the factors affecting the boiling point of liquids?

21. How do you lower the melting point of a substance?

SOLVE THE PROBLEMS

1. An object is heated from 200 K to 350 K. What is the temperature change according to Celsius (Centigrade) scale?

2. Initially, ice is at $-25\text{ }^{\circ}\text{C}$. Then, it is heated and transformed into vapour at $130\text{ }^{\circ}\text{C}$. How many times does a thermometer show constant values during this process?

3. A solid object is heated. The table shows the temperature change of the object with time.

<i>Time (min)</i>	3	6	9	12	15	18	21	24	27	30	33	36	39
<i>Temp ($^{\circ}\text{C}$)</i>	8	9	9	10	12	14	17	19	23	23	23	24	25

a) Draw the temperature-time graph of the table.

b) What is the melting point of the object?

c) What is the boiling point of the object?

ANSWER THE TEST QUESTIONS - I

1. A calorimeter contains water at $0\text{ }^{\circ}\text{C}$ and pieces of floating ice. If the water is stirred with a metal bar for a while, which one of the following can be observed?

- A) Some of the ice pieces melt.
- B) Some of the water freezes.
- C) All of the water freezes.
- D) Nothing changes.

2. The amount of heat needed to change the temperature of a unit mass of a substance by $1\text{ }^{\circ}\text{C}$ is called:

- A) Heat of vaporisation
- B) Specific heat capacity
- C) Heat of fusion
- D) Heating value

3. Two blocks of copper and aluminium have the same mass and temperature of $0\text{ }^{\circ}\text{C}$. They are dropped into two different calorimeters. Each calorimeter has water of 100 g at $60\text{ }^{\circ}\text{C}$. Take specific heat capacity of calorimeters to be zero. Which ONE of the statements is correct when calorimeters reach thermal equilibrium?

- A) The copper has a higher temperature than the aluminium.
- B) The copper has a lower temperature than the aluminium.

- C) The temperatures of the two calorimeters are the same.
- D) The answer depends on the volumes of the metal blocks.

4. Which of the following is the process by which a solid changes directly to a gas?

- A) Melting
- B) Evaporation
- C) Freezing
- D) Sublimation

5. When a sample of vapour condenses into a liquid, ...

- A) it gains heat.
- B) it loses heat.
- C) its temperature rises.
- D) its temperature drops.

6. In the SI unit system heat is measured in

- A) Newtons
- B) Kilograms
- C) Metres

D) Joules

7. During boiling of water,

I. the molecules of water move faster.

II. the temperature of water increases.

III. the water molecules move slowly.

IV. the temperature doesn't change.

Which of the statements above are correct?

A) I and II

B) I, II, IV

C) I and IV

D) II, III and IV

8. 100 g of water at 0 °C is added to 80 g of water at 90 °C.
Calculate the final temperature of the mixture.

A) 20 °C

B) 40 °C

C) 45 °C

D) 60 °C

ANSWER THE QUESTIONS 9, 10 AND 11 LOOKING AT THE INFORMATION BELOW.

An iron block at 200 °C is dropped into a calorimeter which contains 50 g of water. The calorimeter is tightly closed. The graph below shows the temperature changes of water.

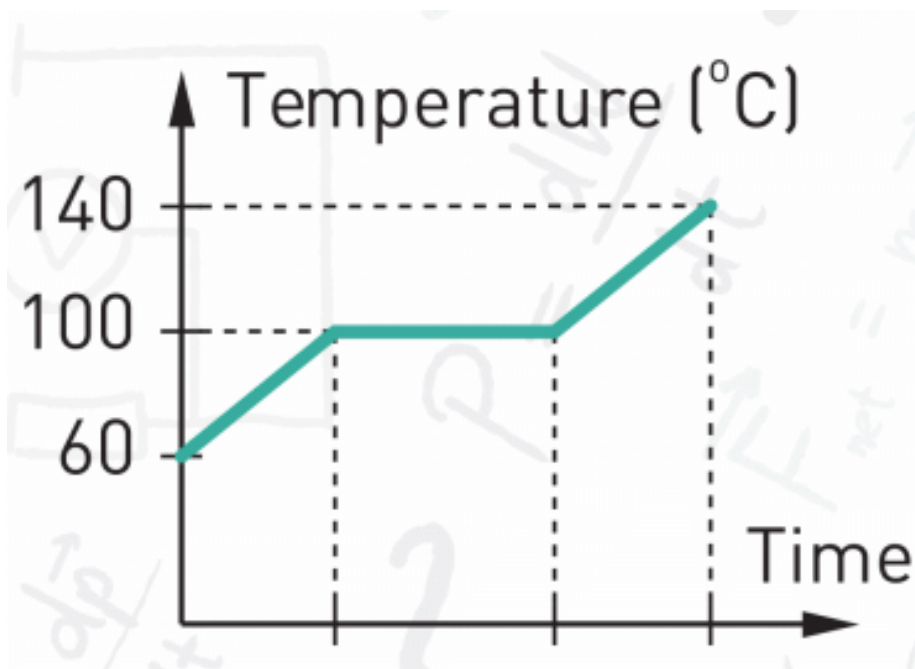

9. What is the final temperature of the iron?

- A) 60 °C
- B) 100 °C
- C) 140 °C

D) 200 °C

10. How much energy did the water gain when it became vapour at 140 °C?

A) 24 kJ

B) 27 kJ

C) 28 kJ

D) 12.5 kJ

11. What is the mass of the iron?

A) 5 kg

B) 2 kg

C) 200 g

D) 500 g

ANSWER THE TEST QUESTIONS - II

The figure shows a temperature-time graph of a solid.
Answer the questions 1, 2, 3 and 4 according to the graph.

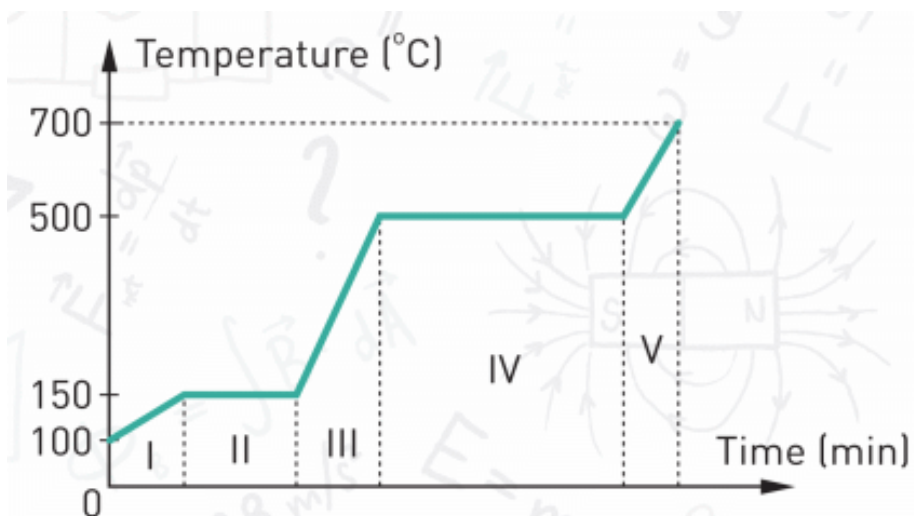

1. Which part of the graph shows the liquid state of the substance?

- A) II
- B) III
- C) IV
- D) V

2. What is the melting point of the substance?

- A) 700 °C
- B) 500 °C
- C) 150 °C

D) 100 °C

3. What is the boiling point of the substance?

A) 700 °C

B) between 700 °C and 500 °C

C) 500 °C

D) 150 °C

4. In which part of the graph do both liquid and gas states of the substance exist?

A) I

B) II

C) III

D) IV

5. Circle the incorrect statement below.

A) During state change of a substance, temperature changes slowly.

B) The specific heat of fusion of a substance is equal to the specific heat of freezing of the same substance.

C) Evaporation is the change from a liquid state to a gaseous state.

D) The heat lost is always equal to the heat gained in a closed system.

6. Which one of the following cannot be a unit of specific heat capacity?

A) J/kg K

B) J°C

7. We have two containers. One contains water and the other contains olive oil. Both liquids have the same mass and the same temperature. If we supply equal amounts of heat to both, which one of the below will be correct for the final temperatures of the liquids?

A) $T_{\text{water}} = T_{\text{oil}}$

B) $T_{\text{water}} > T_{\text{oil}}$

C) $T_{\text{oil}} > T_{\text{water}}$

PHYSICS IN LIFE

1. Why do hail, rain and snow fall from clouds? How do clouds form? Is it cold or hot high in the sky? Why do mountains have snow on their peaks even in summer?

2.



3. How does dew form? Why do we usually see dew in the morning?



4. Why do fog and mist form? When do fog and mist form?



5. At the top of Everest you can heat water until 70 °C and not higher. Why?



CHAPTER 3

THERMODYNAMICS

3.1 FIRST LAW OF THERMODYNAMICS

3.2 SECOND LAW OF THERMODYNAMICS

3.3 HEAT ENGINES

3.4 EFFICIENCY OF HEAT ENGINE

3.5 ECOLOGY AND ENERGY

SUMMARY

PROBLEMS



3.1 FIRST LAW OF THERMODYNAMICS

YOU WILL:

- explain the first law of thermodynamics.

QUESTION

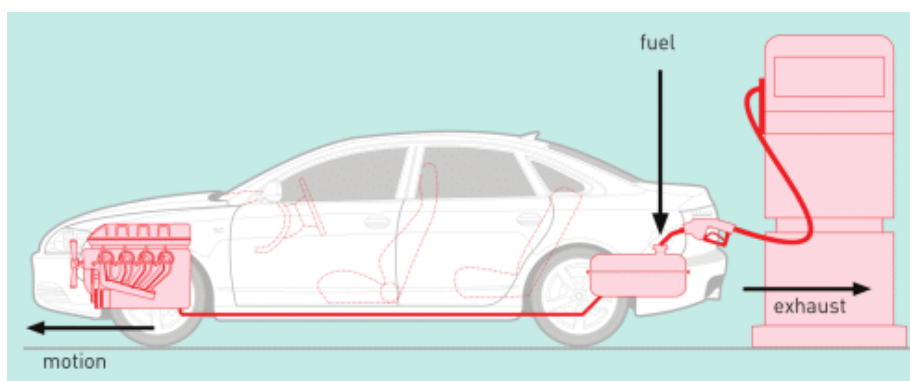

Why do cars have exhaust pipes?

FIRST LAW OF THERMODYNAMICS

Көліктер жанармайдың көмегімен жүреді. Онымен қоса, жанармай жанған кезде көлік қозғалтқышы қызады және сыртқа ыстық газ бөлінеді. Бұл энергияның бір бөлігі жылуға айналып, сыртқа кететінін білдіреді. Ал, энергияның екінші бөлігі көлікті қозғалтуға жұмсалады, Figure 1. Мысалы, бензин жанғанда 1000 Дж энергия бөледі. Осының 300 Дж энергиясы көлікті қозғалтуға жұмсалса, қалған 700 Дж жылулық энергияға айналады. Жылу процесіндегі энергияның түрленуін

"Термодинамиканың бірінші заңы" жақсы сипаттайды. "Thermo" - "жылу", ал "dynamics" - "қозғалыс" дегенді білдіреді.

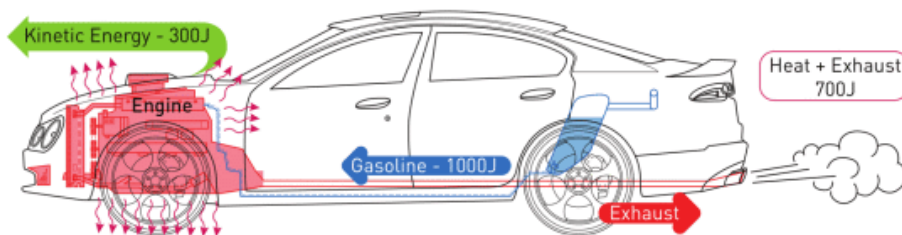

Figure 1

Термодинамиканың бірінші заңы:

$$Q = \Delta U + A$$

Q	=	ΔU	+	A
Heat		Change in internal energy		Work

Жоғардағы мысалда

- 300 Дж дегеніміз пайдалы жұмыс (A)
- 700 Дж дегеніміз ішкі энергияның өзгерісі (ΔU)
- 1000 Дж дегеніміз Жылу (Q)

"Ішкі энергияның өзгерісі" деген түсінікті, жүйедегі кейбір заттардың температурасының өзгеруіне қолданамыз. Жоғарда келтірілген мысалда ол қызған қозғалтқыш және бөлінген газ болып табылады. Себебі олардың температурасы өседі, яғни өзгереді.

Термодинамиканың бірінші заңы кез келген, сыртқы ортамен энергия алмасатын, жүйе үшін жарамды. Және

энергия қолданып, жұмыс жасайтын кез келген құрылғыға қолданыла алады. Басқа да мысалдарды Figure 2-де келтірілген.

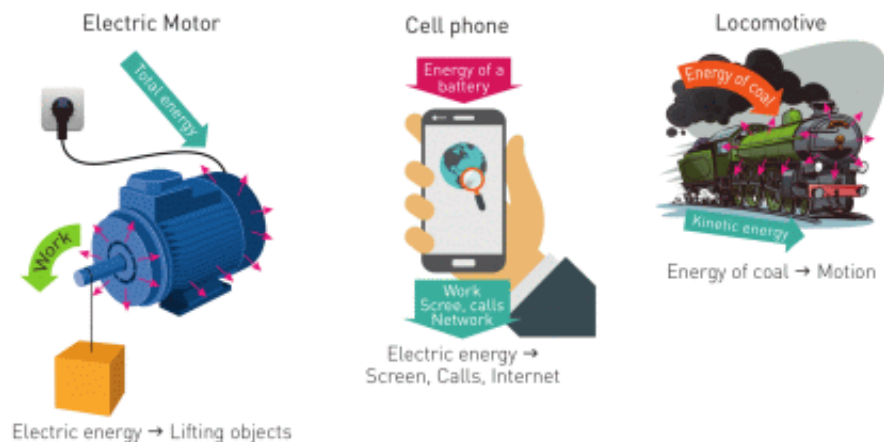

Figure 2

ACTIVITY

Әр суреттен пайдалы жұмысты (A), ішкі энергия өзгерісін (ΔU) және толық энергияны (Q) анықтаңыз.

1. Бала түскі астан кейін сыртқа ойнауға шығады. Баланың денесінің температурасы 36.6°C . Сыртқы ауа райының температурасы 23°C .



2. Электр машинасы қозғалып келе жатыр.



3. Ұшақ ұшып келе жатыр.



4. Әуе шары аспанда қалқып тұр. Шардың ішіндегі ауаны қыздыру үшін газ қолданылады.



5. Электр станциясы суды қайнату үшін көмір жағады. Су буы турбинаны және генераторды айналдырады. Ал генератор электр энергиясын шығарады.

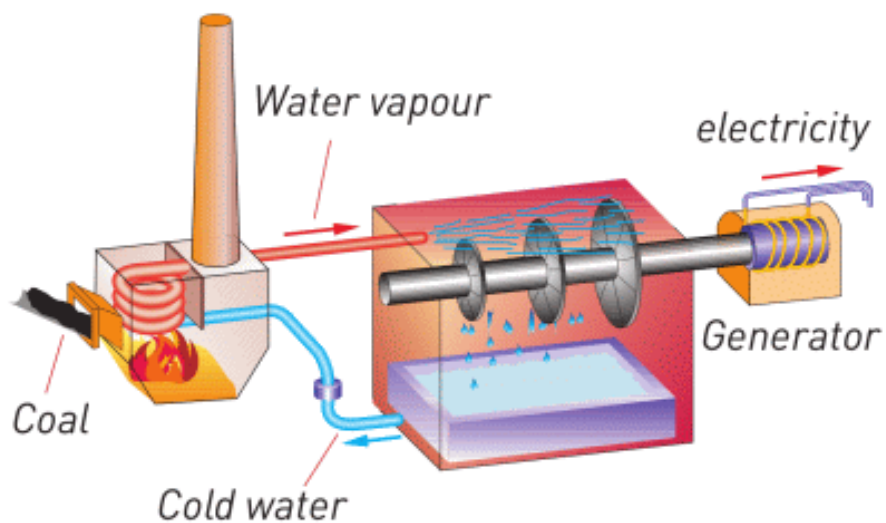

EXAMPLE



A crane engine uses 80000 J obtained from diesel burning. It spends 30000 J to lift a container. What is the change in internal energy? Where does this energy go?

Solution:

$$Q = 80\,000 \text{ Joules}$$

$$A = 30\,000 \text{ J}$$

$$Q = \Delta U + W$$

$$\Delta U = Q - W$$

$$\Delta U = 80\,000 \text{ J} - 30\,000 \text{ J}$$

$$\Delta U = 50\,000 \text{ J}$$

Cranes engine becomes hot; engine produces hot exhausts and sound. All of these take energy away.

FACT



When snow falls, the air becomes warmer. Water clouds release energy to become snow (ice). This energy heats up air.

FACT

The first law of thermodynamics is the law of conservation of energy in thermal processes.

ART TIME

Make a model of a heat engine. Show it to your parents, teachers and friends.

LITERACY

1. Exhaust takes away 250 J. Engine is heated by 150 J. 100 Joules go to make the car move. How many Joules does gasoline produce?
2. Gasoline gives 800 J to the engine cylinder. Then, piston rotates shaft and shaft rotates wheels. 200 J are used for to rotate wheels. How many joules do go to exhaust pipe?

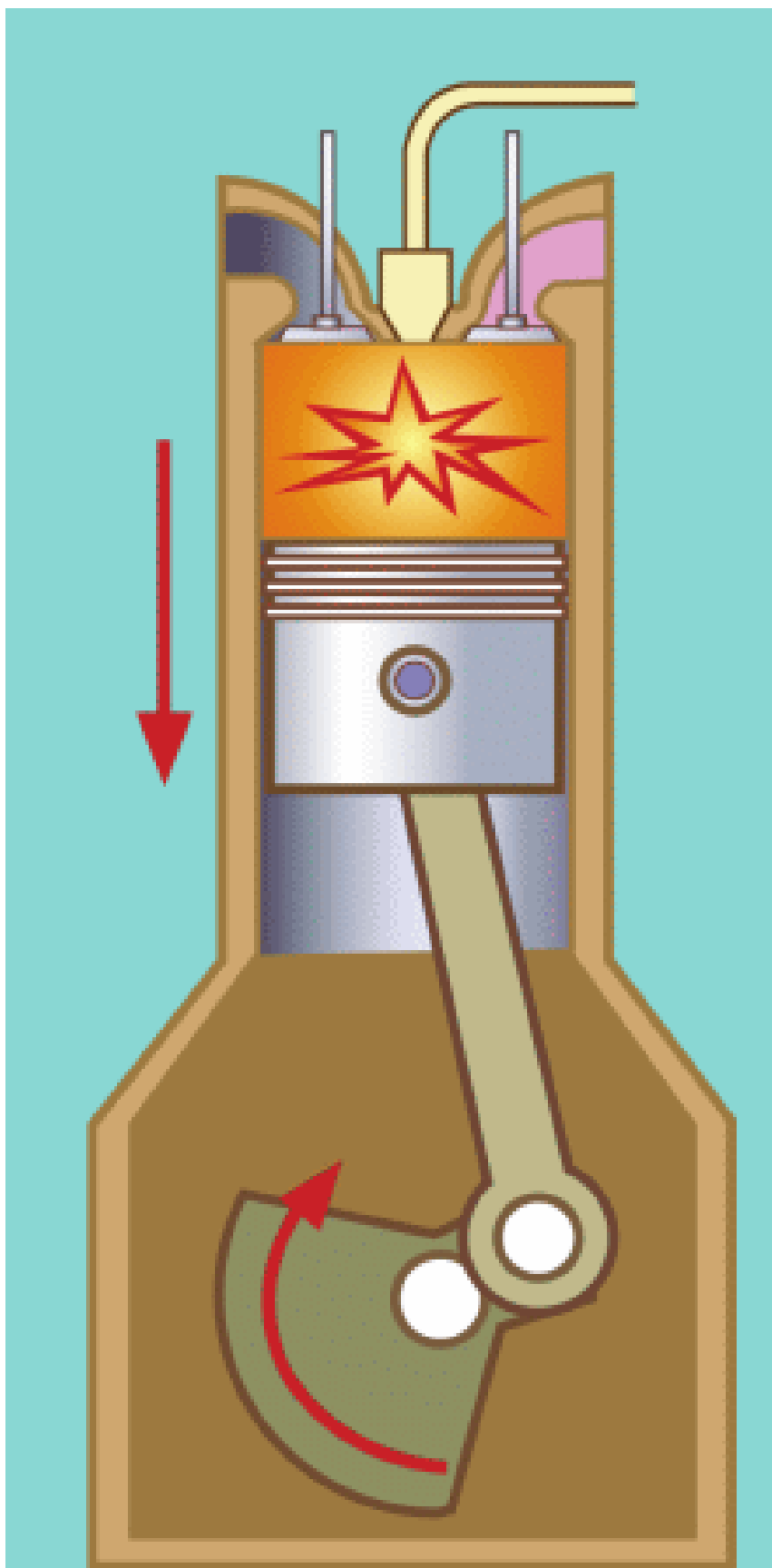

3. “Baikonur” launches a new space rocket. How does rocket spend energy of fuel? Describe it.
4. There is a machine that lifts heavy objects. Imagine that you can use first law of thermodynamics in the following: $A > Q$. What can you say about this machine? Where can we find such machine?
5. What do you think about ΔU ? Is it a good thing that we have? Is it better to have greater ΔU or smaller ΔU ? Why?

TERMINOLOGY

- work – жұмыс / работа
- internal energy – ішкі энергия / внутренняя энергия
- to determine – анықтау / определить
- cylinder – цилиндр / цилиндр
- wheel – дөңгелек / колесо

3.2 SECOND LAW OF THERMODYNAMICS

YOU WILL:

- - explain the second law of thermodynamics.

QUESTION



Look at the flower. Is it possible to reverse the whole process? Explain your answer.

SECOND LAW OF THERMODYNAMICS

Жылу бір жерден екінші жерге берілетіндігін алдыңғы тақырыптардан білеміз. Figure 1 a және Figure 1 b суреттерде жылу ыстық денеден суық денеге беріледі. Және бұл процесс бір бағытты болады, яғни оны кері бағытта алмаймыз. Денелер жылулық тепе-теңдікке жеткен кезде, Figure 1 a, олар өздігінен бұрынғы температураларына қайта орала алмайды. Бұл жылу процесінің қайтымсыздығы деп аталады.

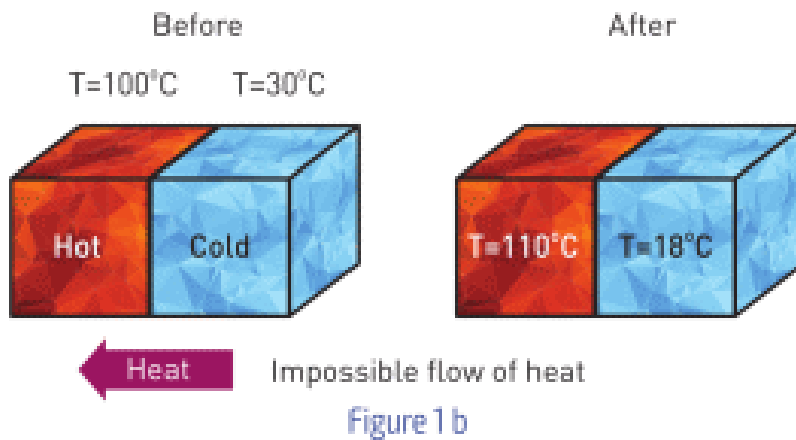
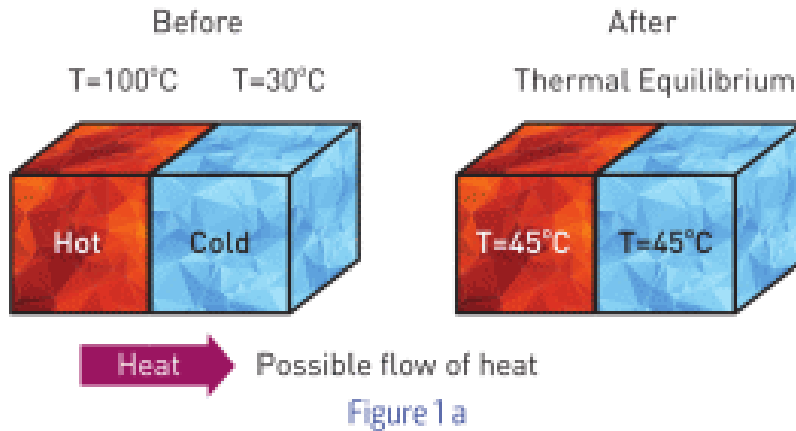

Термодинамиканың бірінші заңы энергияның сақталуына негізделген. Алайда жылу процестерін толықтай сипаттауға бұл заң жеткіліксіз. Себебі бұл заң жылу берілуінің бағытын нақты анықтамайды. Мысалы, Figure 1 b салқын денеден 200 Дж жылу алып, жылу денеге берді делік. Бұл термодинамиканың бірінші заңына қарама-қайшы емес. Алайда, мұндай жылу алмасудың орын алуы өздігінен мүмкін емес екенін білеміз. Сондықтан да жылулық процестерін бағытын нақтылап, термодинамиканың екінші заңын ескеруіміз керек. Бұл заңның екі негізі бар:

а) Жылу өздігінен суық денеден ыстық денеге беріле алмайды;

б) Жылуды толықтай пайдалы жұмысқа айналдыра алатын машина жасау мүмкін емес.

Термодинамиканың екінші заңының бірінші бөлігі жылу процестерінің қайтымсыздығы туралы ақпарат береді. Мысалы, біз ыстық суды суық сумен араластырамыз. Ыстық су жылу энергиясын беріп, суық су дәл сондай мөлшерде жылу энергиясын алады да, екеуіде ортақ температураға келеді. Алайда, кері процесс өздігінен болмайды, яғни бастапқыдай ыстық су мен суық су бөлек шыға алмайды.

Заңның екінші бөлігі барлық жылуды пайдалы жұмысқа айналдыру мүмкін еместігін көрсетеді. Мысалы, машинаның моторы. Мотор жұмыс істеген кезде, ол барлық жылудың белгілі бір мөлшерін ішкі энергиясын арттыру үшін жұмсайды (мотор қызады және сыртқа түтін шығарады). Сол себепті, пайдалы жұмыс толық жылудан аз.

Термодинамиканың екінші заңының осы жылуды толықтай пайдалы жұмысқа айналдыра алатын машина жасау мүмкін еместігін білдіреді.

DISCUSSION

"Time travel"

Sometimes the concept of irreversibility from the second law of thermodynamics is applied to other fields. For example, time travelling. Discuss the relation of the law and time travelling.

RESEARCH TIME

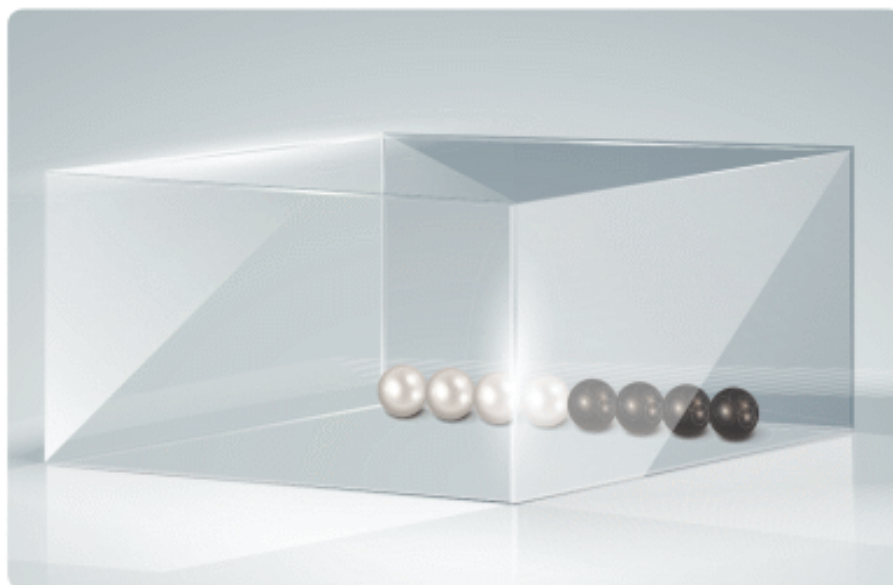

Materials: pan, 5-10 balls of two different colours

Procedure: put them in order as in the picture below, then shake the pan. What happens to balls? Can you bring them to their initial position only by shaking the pan randomly? If you add more balls would it be easier or harder to return balls to initial order?

ACTIVITY

a) Can we name following examples as thermodynamic processes? Prove your answers.

b) Are these processes reversible or irreversible?

1. Melting an ice cube ___YES ___NO
2. Sweating in hot room ___YES ___NO
3. Drying of the drops on our skin ___YES ___NO
4. Sitting on a chair ___YES ___NO

5. Running in the park ___YES ___NO
6. Eating of the meal ___YES ___NO
7. Writing a novel ___YES ___NO

FACT

People tried to build a machine that can work without any energy source. They called it "perpetual motion machine". The laws of thermodynamics proved that it is not possible.

ACTIVITY

Draw any 4 processes that are irreversible. Now imagine that they are reversible. How would it change our world? Would it be good or bad? Why?

ART TIME

Make a video that contradicts the Second Law of Thermodynamics. Show the video to your parents, teachers and friends.

LITERACY

Answer the questions and explain your answers.



1. Can a broken glass become unbroken again by itself?
2. Can a hot cup of tea in a cold room become hotter by itself?
3. Can an apple that falls from a tree jump back to the tree?
4. How can we design a car that makes no exhaust and does not heat up?
5. What if the second law of thermodynamics would not work at all? Explain your answer and give examples.

TERMINOLOGY

- irreversible - қайтымсыз / необратимый
- to reverse - кері шегіндіру / обратить
- previous - алдыңғы / предыдущий
- randomly - кездейсоқ / случайно
- order - қатар/порядок

3.3 HEAT ENGINES

YOU WILL:

- - describe transformations of energy in heat engines;
- - explain working principles of internal combustion engine and steam turbine.

QUESTION



Why do we use cars, trains, airplanes and ships? How do they work? What do they have in common?

HEAT ENGINES

Жылу тек ыстық денеден суық денеге қарай беріледі. Бұл "ыстық" молекулалардың белсенді қимылдауынан болады. Осындай жылу берілу ағынына поршеньді қояр болсақ, ыстық молекулалар суық молекулаларды күшпен итереді, Figure 1 а.

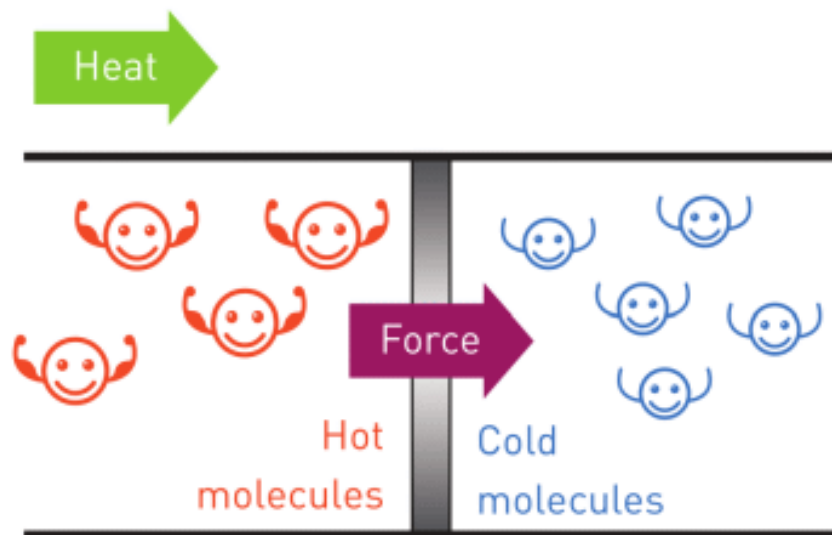

Figure 1 a

Аталған күшті жұмыс атқарушы қозғалтқышты жасауда қолдануға болады. Мысалы, ауыр заттарды көтеретін машина, Figure 1 b. Суретте ағаш жану арқылы газды жылытады. Газ молекулаларының жылдамдықтары артып, газдың көлемі ұлғаяды. Газдың ұлғаюы поршеньді жылжытады. Поршень болса жүк көтереді, яғни жұмыс атқарады.

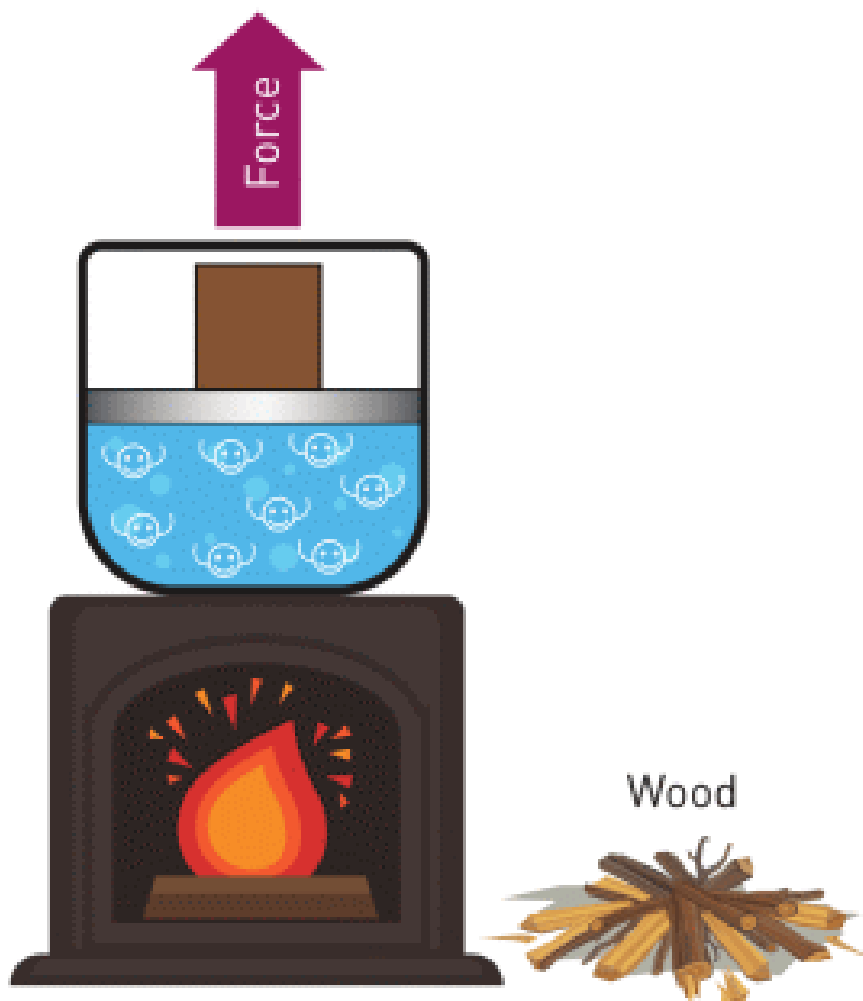

Figure 1 b

Жылу берілуін қолдана отырып жұмыс жасайтын кез келген машинаны жылу қозғалтқышы деп атаймыз. Көліктер, пойыздар, ұшақтар және кемелер жылу қозғалтқыштарға мысалдар.

Жылу қозғалтқышы отынды жағу арқылы жылу $[Q]$ алады. Осы жылудың бір бөлігі жұмыс $[A]$ жасауға жұмсалады. Ал екінші бөлігі машинаның, қоршаған ауаның, жүйенің ішкі энергиясын өзгертеді $[\Delta U]$. Figure 1 b - ге назар аударыңыз.

Ағаш жанғанда бөлінетін энергия [Q]. Поршень жүкті көтереді [A].

Газ, пеш және ауаның температурасы өседі [ΔU]. Ал енді мотоцикл, сүңгуір қайық, ұшақ және локомотив үшін Q, A және ΔU анықтай аласыз ба?

EXAMPLE

An engine burns 6 kg of fuel and produces 6000000 Joules of useful work in 10 minutes. 24000000 Joules goes to exhaust.

- What is the useful power of engine?
- How many Joules does fuel give?
- How much energy does 1 kg of fuel give?

Solution:

$$\begin{aligned} \text{a) } E_{\text{useful}} &= P \times t \\ 6 \times 10^6 &= P \times 600 \\ P &= 10^4 \text{ W} \end{aligned}$$

$$\begin{aligned} \text{b) } E_{\text{total}} &= E_{\text{useful}} + E_{\text{exhaust}} \\ E_{\text{total}} &= 24 \times 10^6 + 6 \times 10^6 \\ E_{\text{total}} &= 30 \times 10^6 \text{ Joules} \end{aligned}$$

$$\begin{aligned} \text{c) } E_{\text{total}} &= m \times q \\ 30 \times 10^6 &= 6 \times q \\ q &= 5 \times 10^6 \text{ J/kg} \end{aligned}$$

	2nd way
1 kg	q
6 kg	30 × 10 ⁶ Joules

$$\begin{aligned} 1 \text{ kg} \times 30 \times 10^6 \text{ Joules} &= 6 \text{ kg} \times \text{Energy} \\ q &= 5 \times 10^6 \text{ Joules} \end{aligned}$$

FACT



The most powerful engine in the world is “Wärtsilä-Sulzer RTA96-C”. Weight: 2300 tons. Power: 80088 kW. It has 14 pistons. It can use up to 250 tons of fuel per day.

ACTIVITY

Мына тапсырмада сіз поршеньді қозғалтқыш пен ауа турбиналарының қалай жұмыс жасайтынын үйренесіз.

Поршеньді қозғалтқыштар: машиналар, ұшақтар, кемелер, мотоциклдер.

Бу турбиналары: электр энергия станциясы.



Figure 2 (Piston engine)



Figure 3 (Steam turbine)

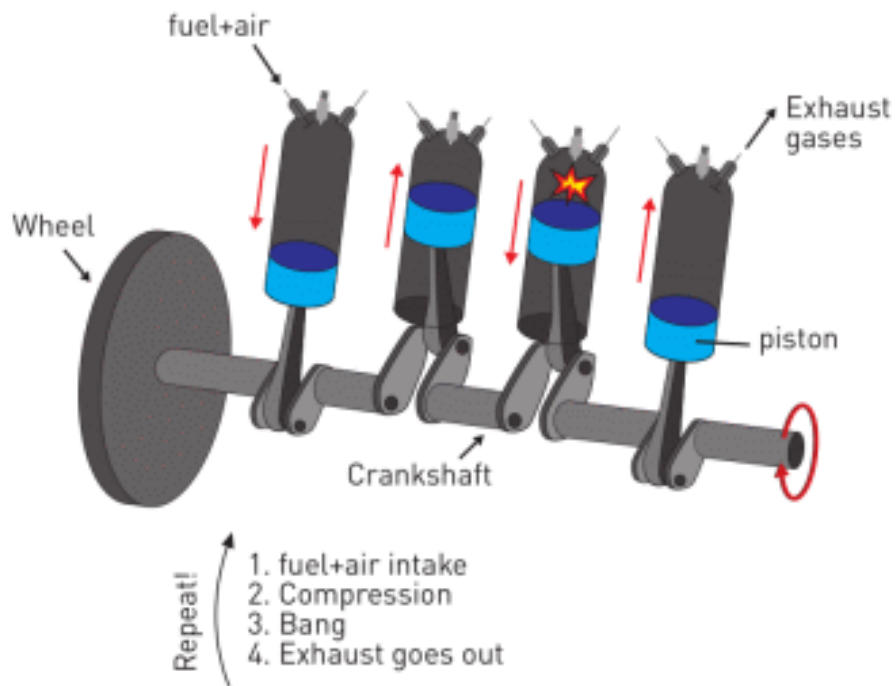

Figure 4

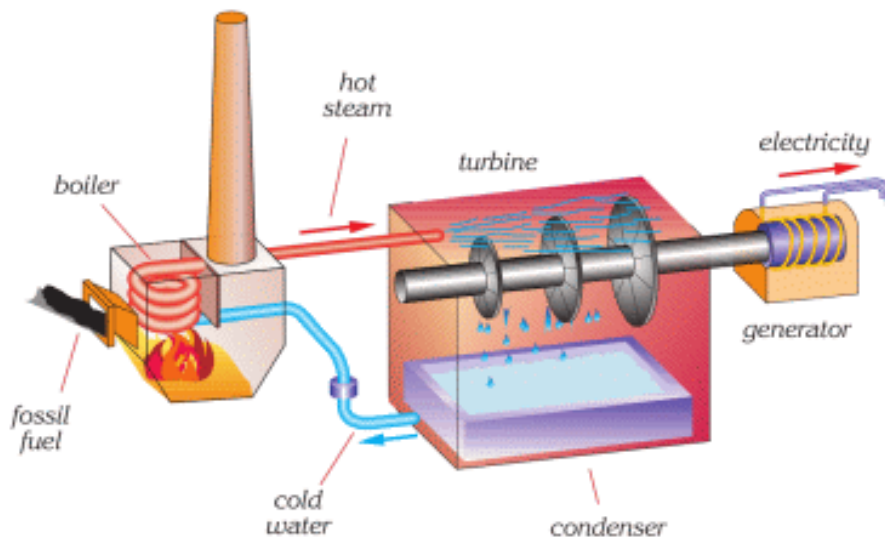

Figure 4

а) Figure 2 және Figure 3-ке қараңыз. Осы суреттер жайлы не айта аласыз?

b) Figure 4 қараңыз. Бұл құрылғылар қалай жұмыс жасайды?

Түсіндіріп көріңіз.

c) Поршеньді қозғалтқыш және бу турбиналарын басқа қай жерде қолдана аламыз? Кез келген пайдалы құрылғының суретін салыңыз.

ART TIME

Make a video that explains heat engine. Show the video to your parents, teachers and friends.

LITERACY

1. What do power stations use to rotate steam turbines?
2. Diesel generator burns 2 kg of diesel and produces 8 kW for in 60 minutes. How many joules does diesel give? How many Joules of electricity does diesel generator produce? How many Joules do go to exhaust? 1 kg of diesel gives 45 MJ (M = Mega =1000000).
3. A cruise ship uses one Wärtsilä-Sulzer engine. Time of travel is 12 days. How much diesel fuel does the ship need?

TERMINOLOGY

- common – ортақ / общий
- submarine – сүңгуір қайық / подводная лодка
- piston – поршень / поршень
- heat engine – жылу қозғалтқышы / тепловой двигатель

3.4 EFFICIENCY OF HEAT ENGINE

YOU WILL:

- - determine efficiency of heat engine;
- - propose methods to increase efficiency of heat engines.

QUESTION

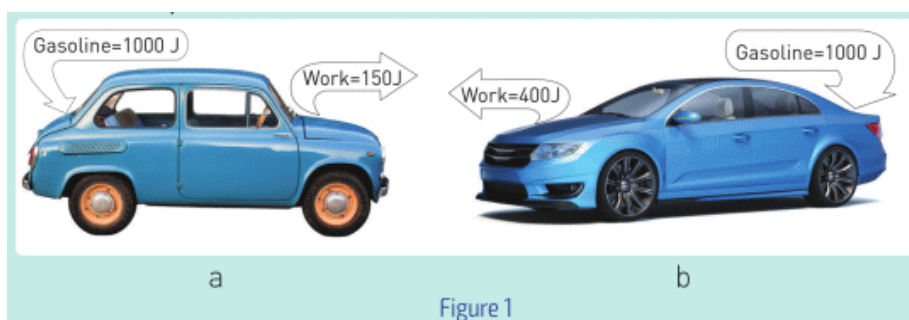

Look at the Figure. Which car uses energy in a better way? Why? Which car produces more exhaust? Which one is more efficient?

EFFICIENCY OF HEAT ENGINE

Барлық жылу қозғалтқыштар жұмыс жасау үшін жылуды қолданады. Figure 1-ді қарасаңыз, (b) көлігі жақсырақ екенін түсінуге болады, себебі ол көбірек жұмыс жасай алады. Бұл сол көліктің пайдалы әсер коэффициенті (ПӘК) жоғары екенін білдіреді. Пайдалы әсер коэффициенті дегеніміз пайдалы жұмысқа жұмсалатын бастапқы энергияның пайыздық көрсеткіші. Ал, Figure 1-

де көрсетілген 2 көліктердің пайдалы әсер коэффициенттерін есептейік:

Car (a) Gasoline gives 1000 J Work: 150 J $1000 \text{ J} = 100 \%$ $150 \text{ J} = X \%$ Solution for X: $X = 15 \%$ Car (a) converts 15% of total energy to work. Efficiency is 15%.	Car (b) Gasoline gives 1000 J Work: 400 J $1000 \text{ J} = 100 \%$ $400 \text{ J} = Y \%$ Solution for Y: $Y = 40 \%$ Car (b) converts 40% of total energy to work. Efficiency is 40%.
--	--

Пайдалы әсер коэффициентінің формуласы:

$$\eta = \frac{\text{Work}}{\text{Total energy}} \times 100\% = \frac{A}{Q} \times 100\% = \frac{Q - \Delta U}{Q} \times 100\%$$

Пайдалы әсер коэффициентіне мысалдар Figure 2-де көрсетілген.







energy given		efficiency		lost energy	
100 J	 human body 	15%	85 J		
100 J	 petrol engine 	25%	75 J		
100 J	 diesel engine 	35%	65 J		
100 J	 electric motor 	80%	20 J		

Figure 2

ACTIVITY

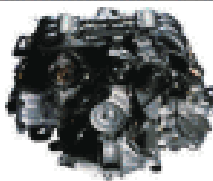
Кез келген құрылғы үшін пайдалы әсер коэффициенті маңызды.

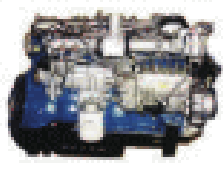
а) Не себепті, кейбір құрылғылардың пайдалы әсер коэффициенті жоғары, ал кейбіреулерінікі төмен?

ә) Кез келген құрылғының пайдалы әсер коэффициентін қалай арттырасыз?

б) Төмендегілерді жақсарту үшін не жасар едіңіз?

1. Поршеньді қозғалтқыш

2. Бу турбины

ФАКТ



Supercharger (turbocharger) pushes more air into engine.
Fuel burns better and gives more energy.

Superchargers (turbochargers) increase efficiency.

ФАКТ



Passenger cars have efficiency no more than 35%-37%

EXAMPLE

Құрылысшылар 50 тонна кірпішті 20 метрге көтеру үшін газ поршенді қолданады.

- a) Газдың атқарған жұмысы неге тен?
- b) Егер $\Delta U = 40000000$ Дж екенін білсек, көмірден барлығы қанша жылу алынды?
- c) Осы жұмысты атқару үшін қанша килограмм көмір керек?
- d) Бұл жылу қозғалтқышының пайдалы әсер коэффициенті қандай (ПӘК)?

Solution:

a) Work(A) is change in potential energy of bricks.
 $A = m \times g \times h$
 $A = 50\,000\text{ kg} \times 10\text{ N/kg} \times 20\text{ m} = 10\,000\,000\text{ Joules.}$

b) 1st law of thermodynamics:
 $Q_{\text{coal}} = \Delta U + A$
 $Q_{\text{coal}} = 40\,000\,000\text{ Joules} + 10\,000\,000\text{ Joules} = 50\,000\,000\text{ Joules.}$

c) Heat of combustion:
 $Q_{\text{coal}} = m \times q$
 $50\,000\,000\text{ Joules} = m \times 20\,000\,000\text{ J/kg}$
 $m = 2.5\text{ kg}$

d) Efficiency formula $\eta = \frac{A}{Q} \times 100\%$.

$$\eta = \frac{10\,000\,000}{50\,000\,000} \times 100\%$$

$$\eta = 0.2 \times 100\%$$

$$\eta = 20\%$$

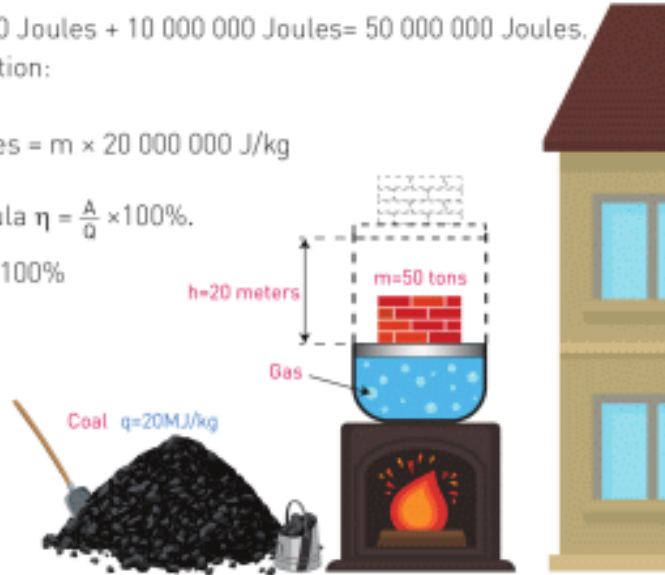

RESEARCH TIME

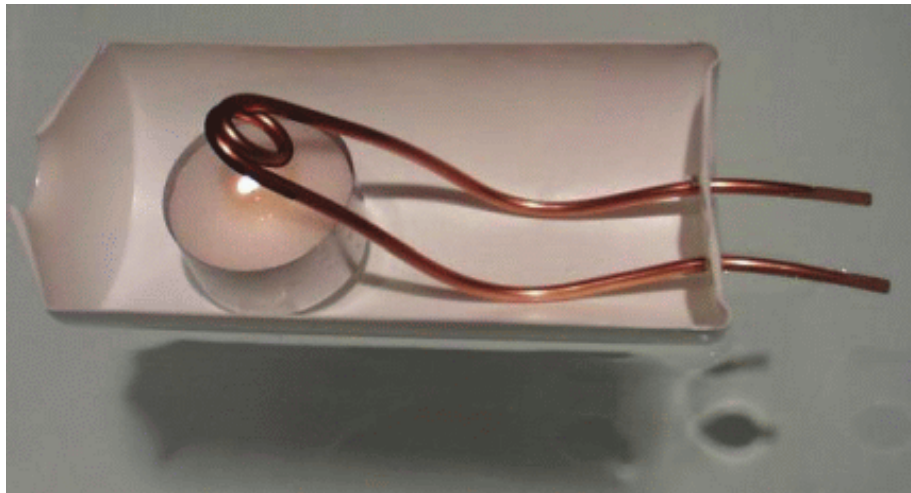

This is a candle boat. It uses heat to move. What kind of other devices can you make?

LITERACY

1. A car uses an engine to move. 400 Joules go to exhaust pipe. 100 Joules are used to move the car. How many Joules does gasoline produce? What is efficiency of the engine?
2. Gasoline and air burn inside the engine cylinder and give 800 Joules. Gasoline pushes piston, piston rotates shaft, shaft rotates wheels. 200 Joules are used to rotate the wheels. How many Joules do go to exhaust pipe? What is efficiency of the engine?
3. An oven burns 30 tons of coal ($q = 30 \text{ MJ/kg}$) to heat water ($C = 4200 \text{ J/kg } ^\circ\text{C}$) from $20 \text{ }^\circ\text{C}$ to $90 \text{ }^\circ\text{C}$. Efficiency of oven is 65%. How much water can it heat?
4. A student eats breakfast of 1000 kJ. Then, she goes running. Her body spends 0.8 Joules of useful energy in 1 second. Efficiency of human body is about 15%. How much time can she run on her breakfast energy?
5. How can we get efficiency of 100%?

ART TIME

Imagine the world where 200 % efficiency existed. What would be different there? How good or bad would that be?
Art time

TERMINOLOGY

- efficiency – пайдалы әсер коэффициенті / коэффициент полезного действия
- percentage – пайыздық қатынас / процентное соотношение
- shaft – иіндік білік / вал

3.5 ECOLOGY AND ENERGY

YOU WILL:

- - estimate the effect of heat engines on ecology of environment.

QUESTION



Is smoke from cars, cigarettes, power plants and factories harmful? How does it affect your health? How does it affect nature (air, water, soil, plants, and animals)? Why do people use cars, power plants and factories? Are there any alternatives?

ECOLOGY AND ENERGY

Адамзат энергиясыз өмір сүре алмайды. Өмірімізде энергияның түр-түрі қолданылады. Энергияның ең басты 5 көзі:

1. ҚАЗБА ОТЫНДАР

Көмір, мұнай және газ қазба отын болып табылады. Қазба отындарды қолдану арзан әрі қолайлы. Алайда, оларды жағу атмосфераның улы газдармен ластануына алып келеді.

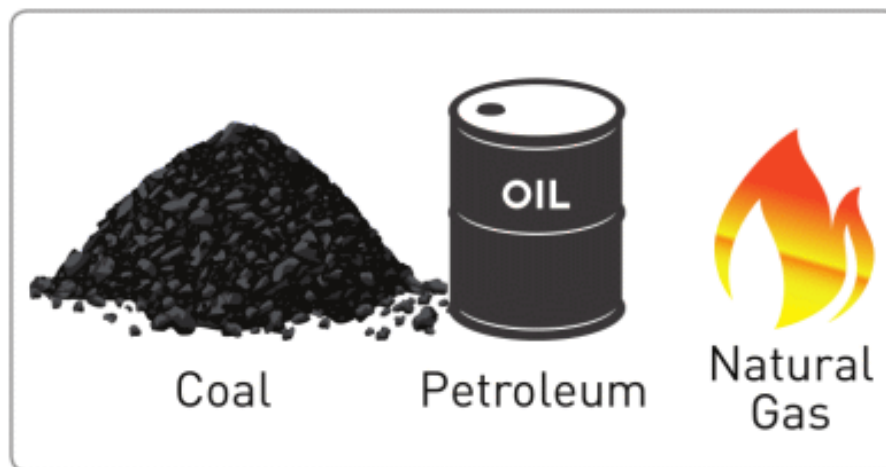

Fossil fuels

2. БИОМАССА ОТЫНДАРЫ

Ағаш, көкөніс пен тезектен алынатын табиғи газдар биомасса отындары деп аталады.

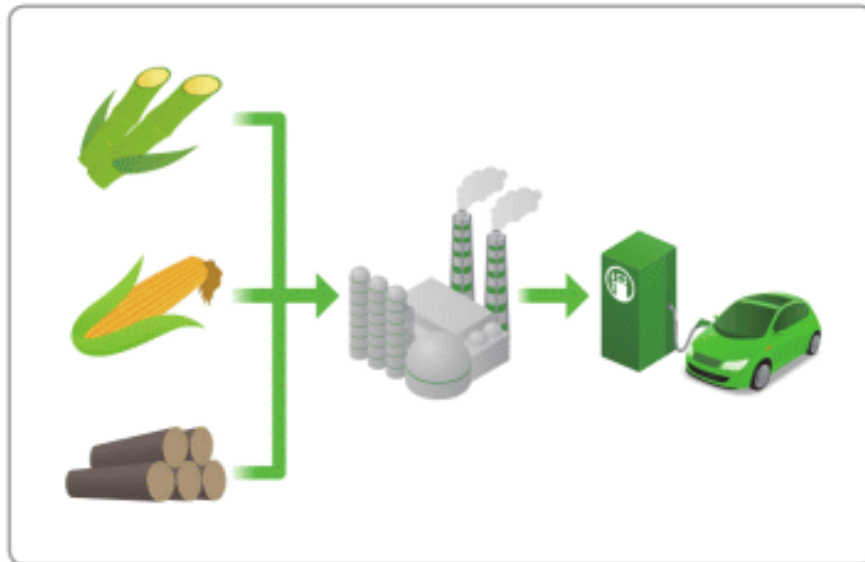

Biomass fuels

3. ЯДРОЛЫҚ ОТЫН

Уран және плутон ядролық отынның түріне жатады. Ядролық отын көмірқышқыл газ шығармайды және өте қуатты болып табылады.

Себебі, 1 кг ядролық отынның қуаты 2200 тонна көмірдің қуатына шамалас. Алайда, ядролық отын тіршілікке аса қауіпті, себебі оның артынан қалған радиоактивті қоқыс жақын орналасқан тіршілік әлеміне орасан зор зиянын тигізеді.



Nuclear power plant

4. СУ ЭНЕРГИЯСЫ

Бұл энергияның сенімді әрі қауіпсіз түрі болып табылады. Алайда аса қуатты болып саналмайды. Су электр станциялары үлкен аумақты қажет етеді. Кейбір кездері су энергиясын қолдану ормандардың кесіліп, жануарлар мен табиғи ағыстардың бұзылуына алып келуі мүмкін.



Water power plant

5. КҮН ЖӘНЕ ЖЕЛ ЭНЕРГИЯСЫ

Жел және Күн сәулесінен энергия алуға болады. Бұл энергия көздері қауіпсіз және экологиялық таза болып табылады.



ACTIVITY

ENERGY DILEMMA

Any energy source has advantages and disadvantages. There are 4 main factors.

- a) Cost and power. How much should we invest in it? How much will energy cost in the future? How powerful is this energy source?
- b) Reliability. How is this source convenient to use? Will it ever end?
- c) Scale. Does this energy source need big area? How many people can use it?
- d) Environmental effects. How safe is this energy source? How does it affect people, air, water, soil, animals, and plants?

	Cost and Power	Reliability	Scale	Environmental effects	Sum total
Fossil fuel					
Biomass Fuel					
Nuclear fuel					
Water power					
Solar and Wind					

Evaluate these energy sources by using scale from 1 to 5 in the table. Give the reasons for your choice.

RESEARCH TIME

Divide into groups and make presentations about "how people take energy" from these five energy sources.

ACTIVITY

RENEWABLE AND NON-RENEWABLE

a) Non-renewable.

This type of energy is finite. We need to wait millions of years to gain this source again.

b) Renewable.

This energy source is not finite. When we use it, we can wait for a short time to use it again. That means energy source will not end.

Divide 5 sources of energy into 2 groups: renewable and non-renewable. Explain your choices.

ACTIVITY

200 YEARS LATER

The table shows how people use sources of energy in the world.

Coal	30%
Petroleum	26%
Gas	20%
Biomass	14%
Nuclear	6%
Water	3%
Solar and Wind	1%

Discuss in groups and answer the questions.

a) Why do people use some types of energies more than others? How does each energy source affect people, air, water, soil, animals, and plants?

b) Imagine the planet after 200 years. How will the data in the table change? Draw your new table. Explain your answers.

c) Draw picture of the world after 200 years. Show life of people and nature. Explain your picture to your friends.

ART TIME

Make an engine that does not harm environment. What materials can you use?

LITERACY

1. How do cars affect ecology? What happens if all people stop using cars?
2. What happens to your health if ecology is bad? How can you make ecology better?
3. Are there any other sources of energy besides 5 examples discussed in this topic?

TERMINOLOGY

- power plant - электр станциясы / электростанция
- factory - зауыт / завод
- alternative - балама / альтернатива
- harmful waste - зиянды қалдықтар / вредные отходы
- renewable - жаңғыртылатын / возобновляемый

SUMMARY

- Conservation of energy in thermal processes is called the first law of thermodynamics. “Thermo” means heat, and “dynamics” means motion.
- We can rewrite this law using a formula:

- $Q = \Delta U + A$

-

$$\begin{array}{ccccccc}
 Q & = & \Delta U & + & A \\
 \text{Heat} & & \text{Change in} & & \text{Work} \\
 & & \text{internal} & & \\
 & & \text{energy} & &
 \end{array}$$

-

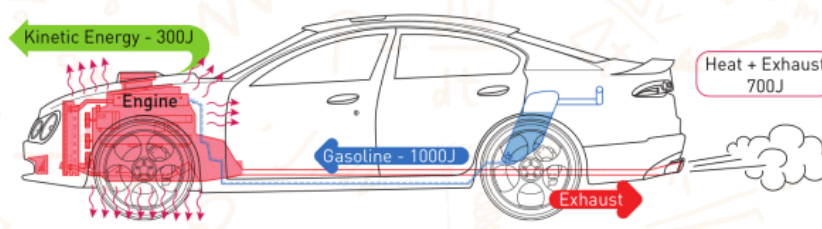

- We need to have additional law which includes direction of flow of heat; it is called the second law of thermodynamics. This law has two main parts.
- a) Heat cannot flow from colder objects towards hotter objects by itself.
- b) There is no such a heat machine a heat machine that can convert all heat into useful work.

-

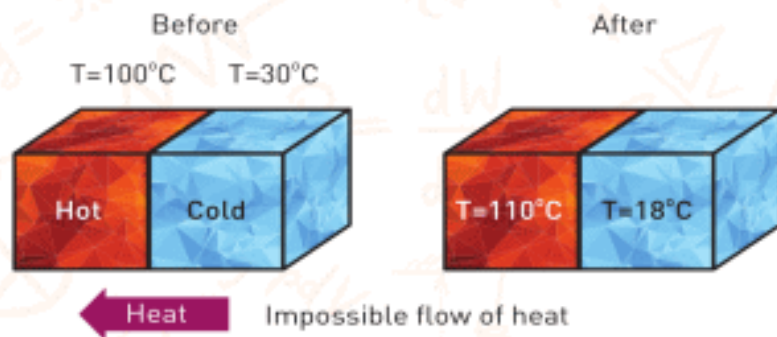
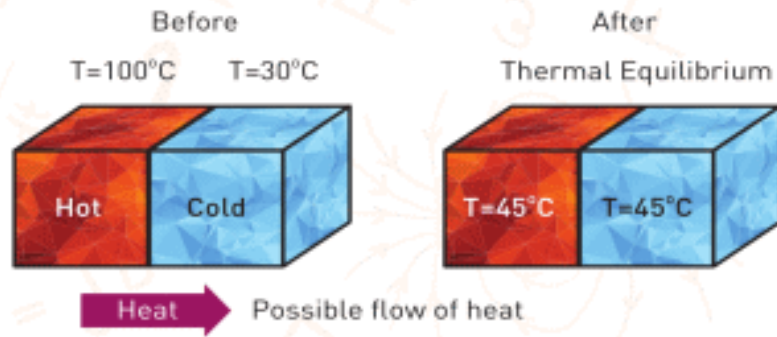



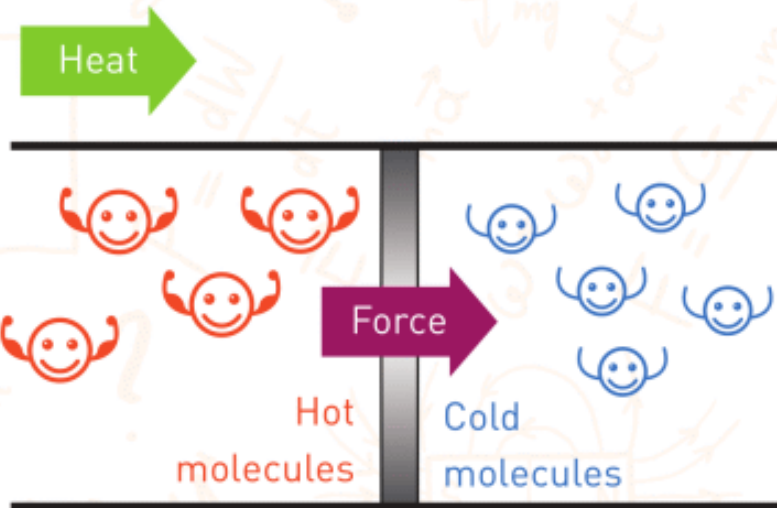

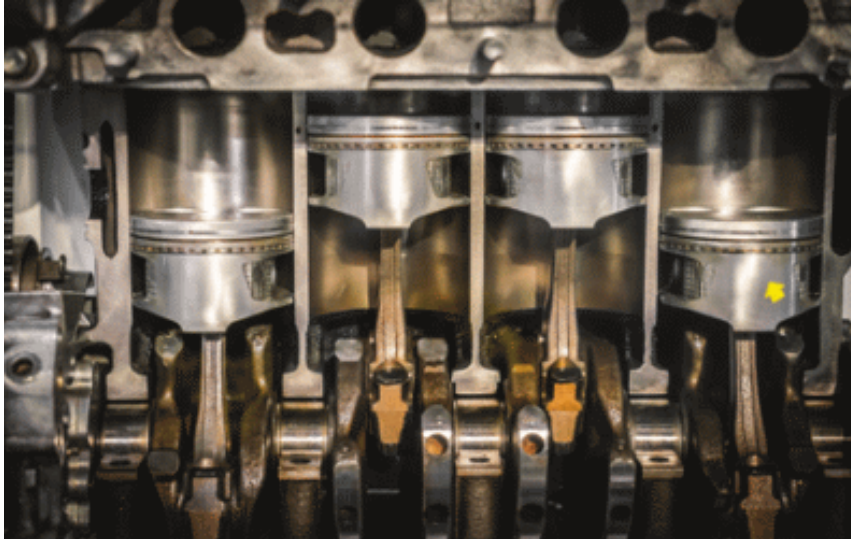

- Any machine that uses heat to do work is called heat engine. Cars, trains, airplanes and ships use heat engines.



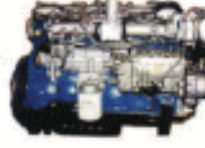

- Efficiency is the percentage of total energy that goes to useful work.
- The formula of efficiency is:

$$\eta = \frac{\text{Work}}{\text{Total energy}} \times 100\% = \frac{A}{Q} \times 100\% = \frac{Q - \Delta U}{Q} \times 100\%$$

energy given		efficiency		lost energy	
100 J	 human body 	15%		85 J	
100 J	 petrol engine 	25%		75 J	
100 J	 diesel engine 	35%		65 J	
100 J	 electric motor 	80%		20 J	

There are 5 main sources of energy.

1. Fossil fuel
2. Biomass fuel
3. Nuclear fuel
4. Water power
5. Sun and wind power

PROBLEMS

THE FIRST LAW OF THERMODYNAMICS

1. A heat engine does 320 J of work, as it takes 700 J heat from gasoline. What is the internal energy change?
2. The internal energy of a turbine increases by 280 J when it does 185 J of work. How much heat did turbine take?
3. The gas sample in the frictionless cylinder-piston system expands. It takes 175 J of heat energy. The mass of the piston is 50 kg. What is the internal energy change of the gas during the process?

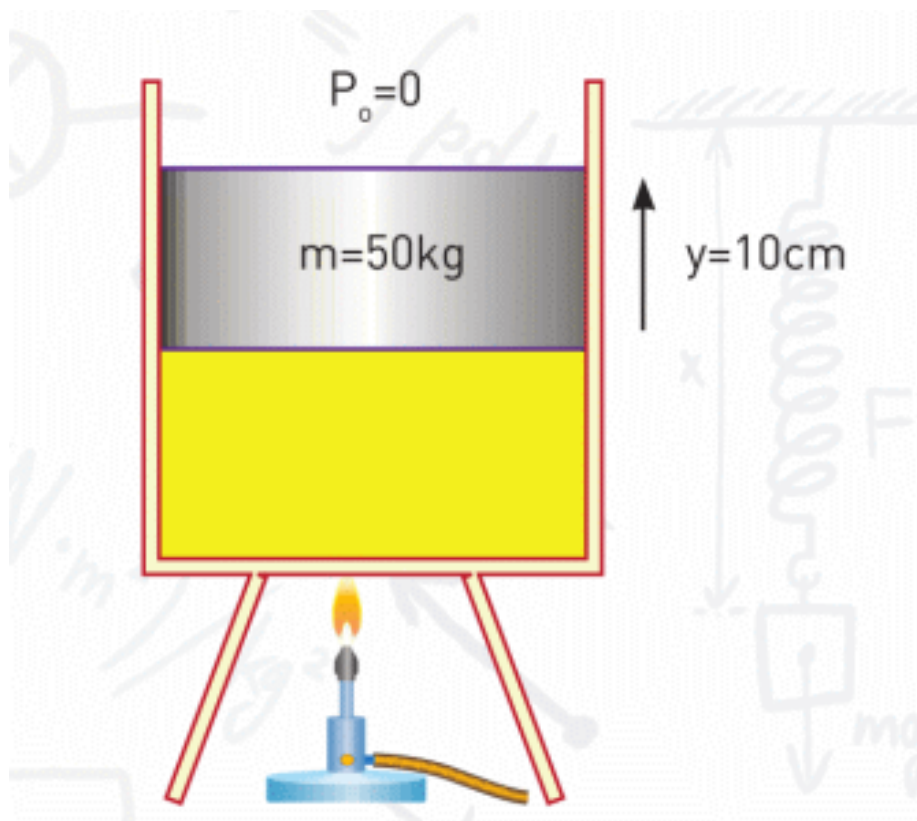

HEAT ENGINES

1. A heat engine does 3000 J of work and releases 2000 J of heat from its exhaust. What is the efficiency of this engine?

2. A heat engine of $\eta = 30\%$, loses 5000 J heat. What is the work done by the engine?

3. A steam power plant burns 50 tons of coal every hour. The useful power of the plant is 130 MW. $q_{\text{coal}} = 30 \text{ MJ/kg}$

a) How much useful energy does the power plant produce in 1 hour?

b) How much energy does coal give in one hour?

c) What is the efficiency of this plant?

4. Power plant of 500 MW of useful power has an efficiency of 0.45.

a) What is the useful energy produced by the plant per day?

b) How much heat energy is released to the surroundings per day?

5. A heat engine takes 480 J of heat. Work equals to one-fourth ($\frac{1}{4}$) of change in internal energy. What is A and ΔU ?

6. An automobile's motor produces 32 kW of useful power while it travels 40 km at a constant speed of 80 km/h. During the journey it uses 4 kg of diesel fuel. Find the efficiency of the motor. ($q_{\text{fuel}} = 42 \text{ MJ/kg}$)

7. A car travels 300 km at a speed of 75 km/h. Efficiency of car's engine is 25%. Useful power is 52 kW. How much diesel fuel did car use? ($q_{\text{diesel}} = 42 \text{ MJ/kg}$)

8. Classify the following examples into two groups:

I. Allowed by first law, but not allowed by second law.

II. Not allowed by both first and second laws.

a) A heat engine absorbs 100 J of heat and does 100 J work

b) A heat engine absorbs 100 J of heat and does 110 J of work

c) The cold body releases 20 J of heat, the hot body absorbs these 20 J of heat.

d) A coin lying on a table suddenly gets colder by itself and jumps upwards.

e) A glass of water at room temperature turns into ice, making the air slightly hotter.

f) A mixture of salt and pepper is separated by shaking.

ANSWER THE TEST QUESTIONS

1.

I. heat

II. carbon dioxide

III. oxygen

IV. combustible substance

Which of the above are necessary for burning?

A) I, II, III

B) II, III

C) I, III, IV

D) I, II, III, IV

2. Which one is not a property of a good fuel?

A) Must burn at a steady rate.

B) Must give energy in huge amounts.

C) Must not release poisonous substances.

D) Must be expensive.

PHYSICS IN LIFE

1. When you pour 10 litres of gasoline, the car “loses” about 6 litres. What does it mean?



2. Airplanes use rotating turbines. Why?



3. There are some “explosions” in every car. Why?

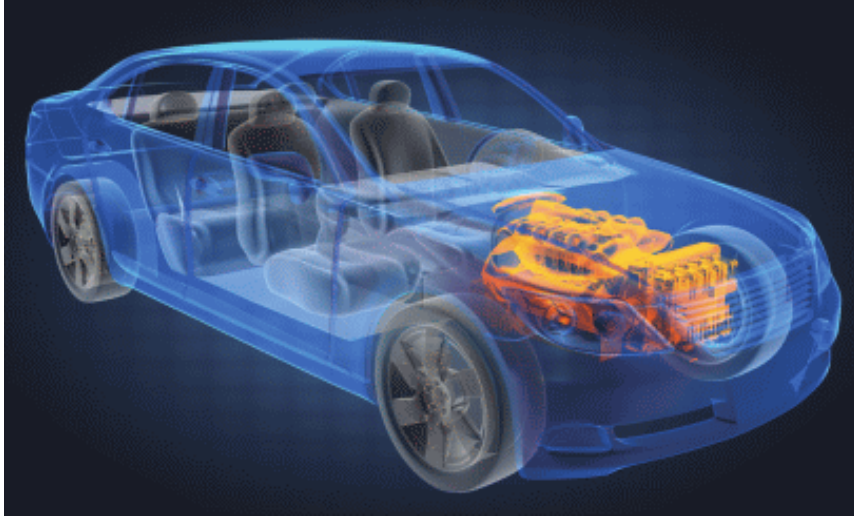

4. We get about 60% of electricity from coal. How?



5. Wind turbines and solar panels are called “sources of green technology”. What is the reason?



CHAPTER 4

ELECTROSTATICS

4.1 ELECTRIC CHARGE

4.2 CHARGING METHODS

4.3 CONSERVATION OF CHARGE. COULOMB'S LAW

4.4 ELECTRIC FIELD PART 1

4.5 ELECTRIC FIELD PART 2

4.6 ELECTRIC POTENTIAL. POTENTIAL DIFFERENCE

4.7 CAPACITANCE & CAPACITORS

SUMMARY

PROBLEMS



4.1 ELECTRIC CHARGE

YOU WILL:

- - characterize electric charge;
- - explain charging by friction and induction;
- - give examples of positive and negative effects of charging.

QUESTION

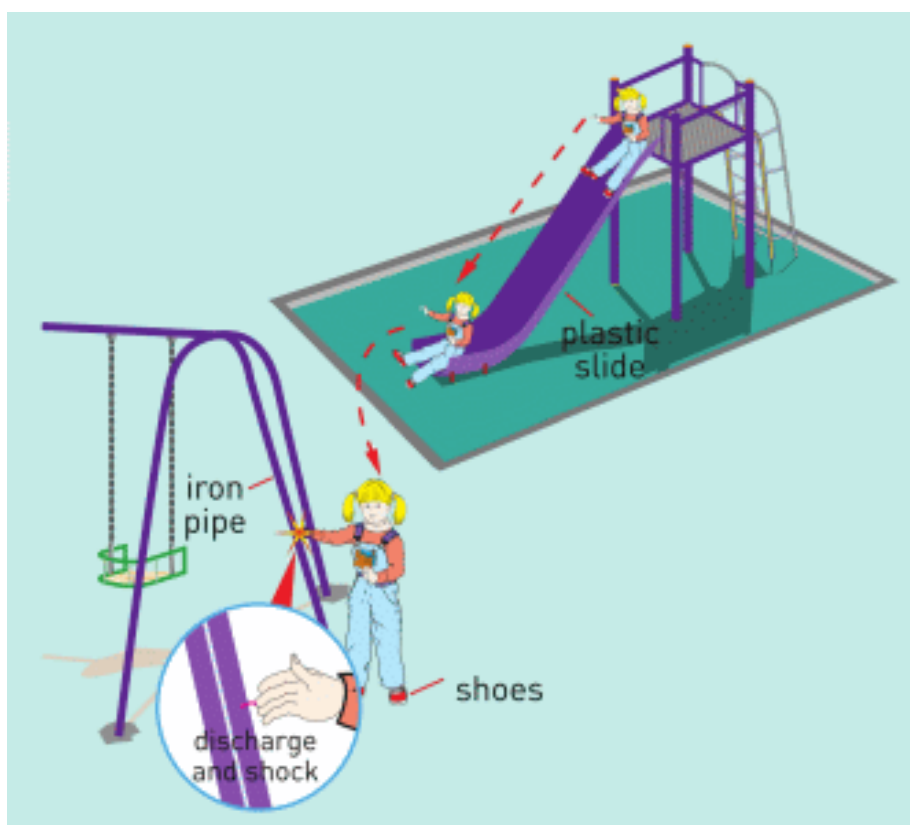

What is happening in the picture?

ELECTRIC CHARGE

An atom consists of 3 main particles: Nucleus: protons, neutrons and electrons.

a) Protons: positive (plus) charges. The number of protons defines a type of substance. For example, iron-26 protons, copper-29 protons.

b) Neutrons: neutral (zero) particles of an atom.

c) Electrons: negative charges (minus). They rotate around the nucleus. Electrons help to connect to other atoms, Figure 1.

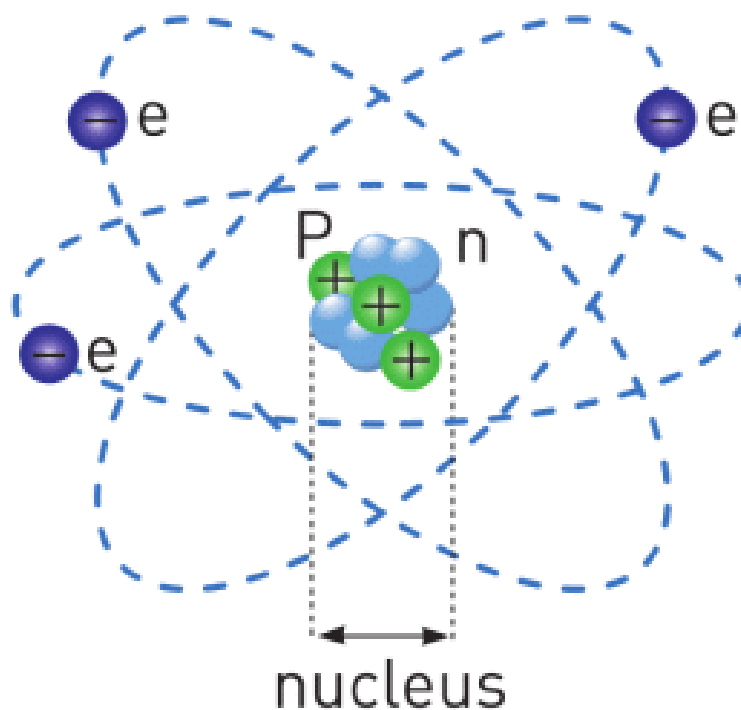

Figure 1

Зарядтар бір-біріне тартылады немесе бір-бірінен тебіледі.

Атас (бірдей) зарядтар бір-бірінен тебіледі, ал әр атас (қарамақарсы) зарядтар бір-біріне тартылады, Figure 2.

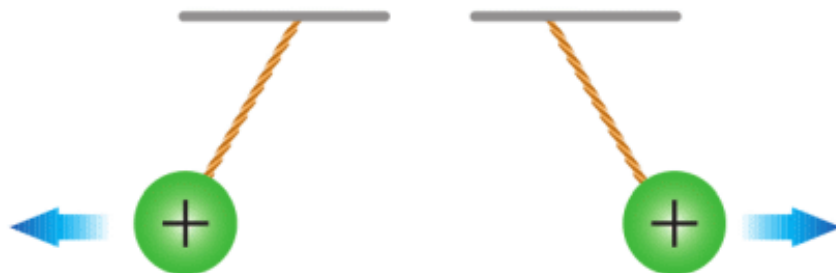

Figure 2

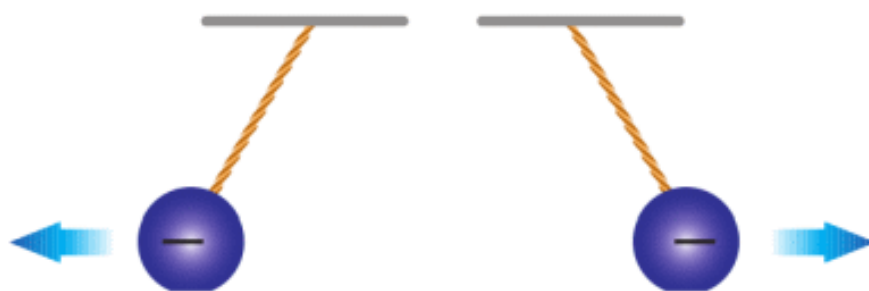

Figure 2



Figure 2

Зарядтардың тартылуы мен тебілуіне себеп болатын күш электростатикалық күш деп аталады.

Мысал ретінде шашыңыз пластикалық тарақпен таралғанда тарақ электрленеді. Осы тарақты ұсақталған қағаздарға жақындатқанда, электростатикалық күштің әсерінен қағаздар тараққа тартылады, Figure 3.

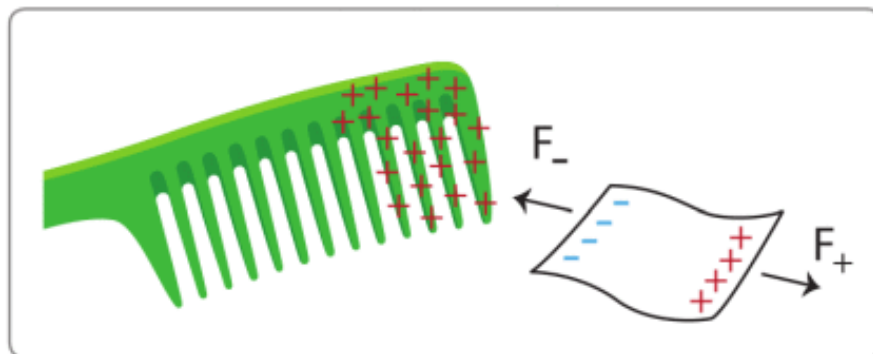
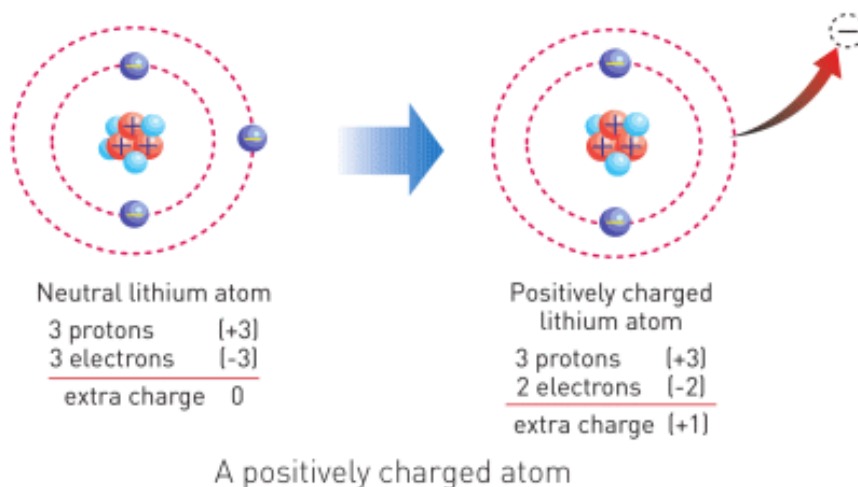
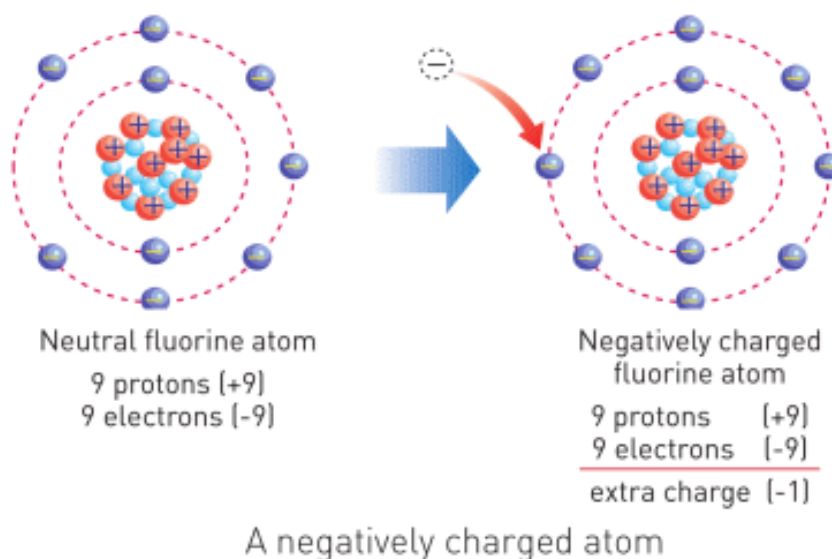

Figure 3

Металл өткізгіштерде электрондар бір денеден екінші денеге еркін өтіп қозғала алады. Ал протондар мен нейтрондар, атом ядросында орналасқаны үшін қозғала алмайды.

Теріс зарядты дененің электрондар саны протондар санынан көбірек болса, оң зарядты дененің протондар саны электрондар санынан көбірек болады. Егер де, денеде электрондар мен протондар саны бірдей болса, ол бейтарап зарядты дене деп аталады.



IT-LINK

Go to phet.colorado.edu.

Search “Balloons and Static electricity” and “John Travoltage”.

FACT

Electric charge is a physical quantity and its SI unit is the Coulomb (C). In practice, we use microcoulomb = $\mu\text{C} = 0.000001 \text{ C}$ and nanocoulomb = $\text{nC} = 0.000000001 \text{ C}$

FACT

Painting by charging. A car is positively charged. Paint droplets are negatively charged. Paint lays thin and uniform.

EXAMPLE

№	Proton	Neutron	Electron	Positive	Negative
1	8	8	9		✓
2	16	16	13		
3	3	3	3		
4	24	24	25		
5	5	5	4		

Fill the table.

RESEARCH TIME

Шарларды үрлеп, оларды бір-біріне жақын іліңіз (тигізбей).

Тәжірибе №1.

Оларды жүннен жасалған матамен үйкеп, өзгерісті бақылаңыз.

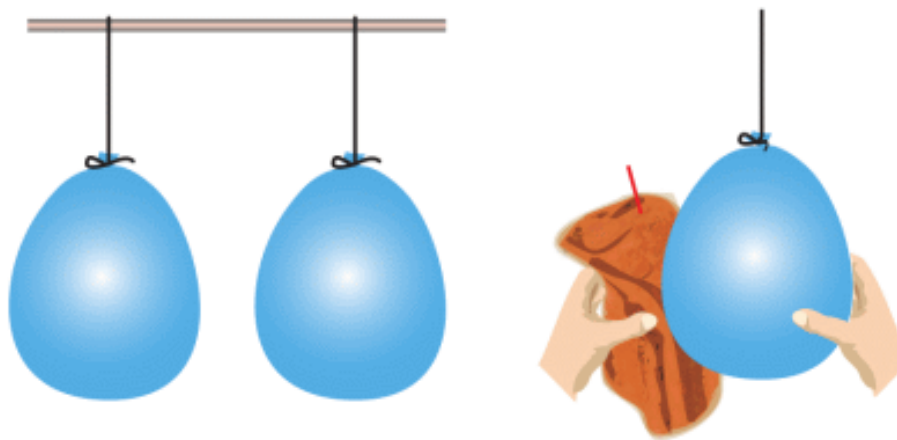

Experiment 1

Тәжірибе №2.

1-ші шарды жүннен жасалған матамен, 2-ші шарды нейлоннан жасалған матамен үйкеп, өзгерісті бақылаңыз.

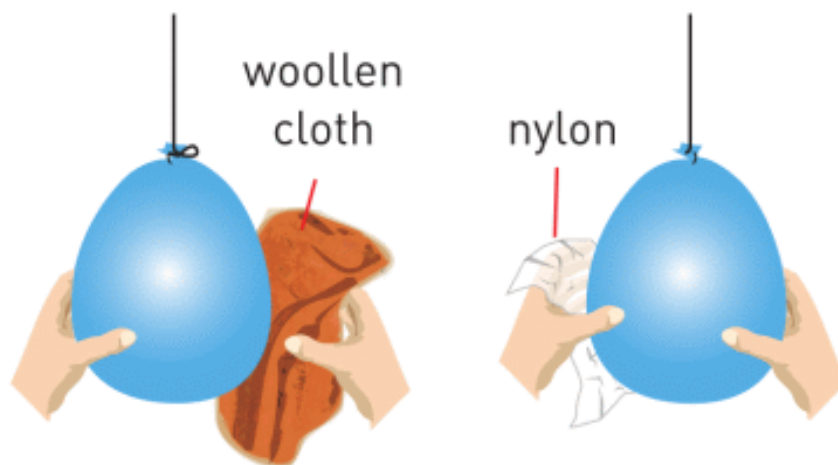

Experiment 2

LITERACY

1. When a bee collects pollen, it rubs itself with legs. Why?
2. What would happen if protons easily moved as electrons?
3. How can you prevent shock when you play on a plastic slide?
4. What is happening in the picture below?



ART TIME

Make origami (paper model) of an atom (protons, neutrons and electrons). Show it to your parents, teachers and friends.

TERMINOLOGY

charge - заряд / заряд nucleus - ядро / ядро

electrostatic - электростатикалық / электростатически

positive - оң / положительный

negative - теріс / отрицательный

4.2 CHARGING METHODS

YOU WILL:

- - explain charging by rubbing, induction and contact;
- - give examples of positive and negative effects of charging.

QUESTION

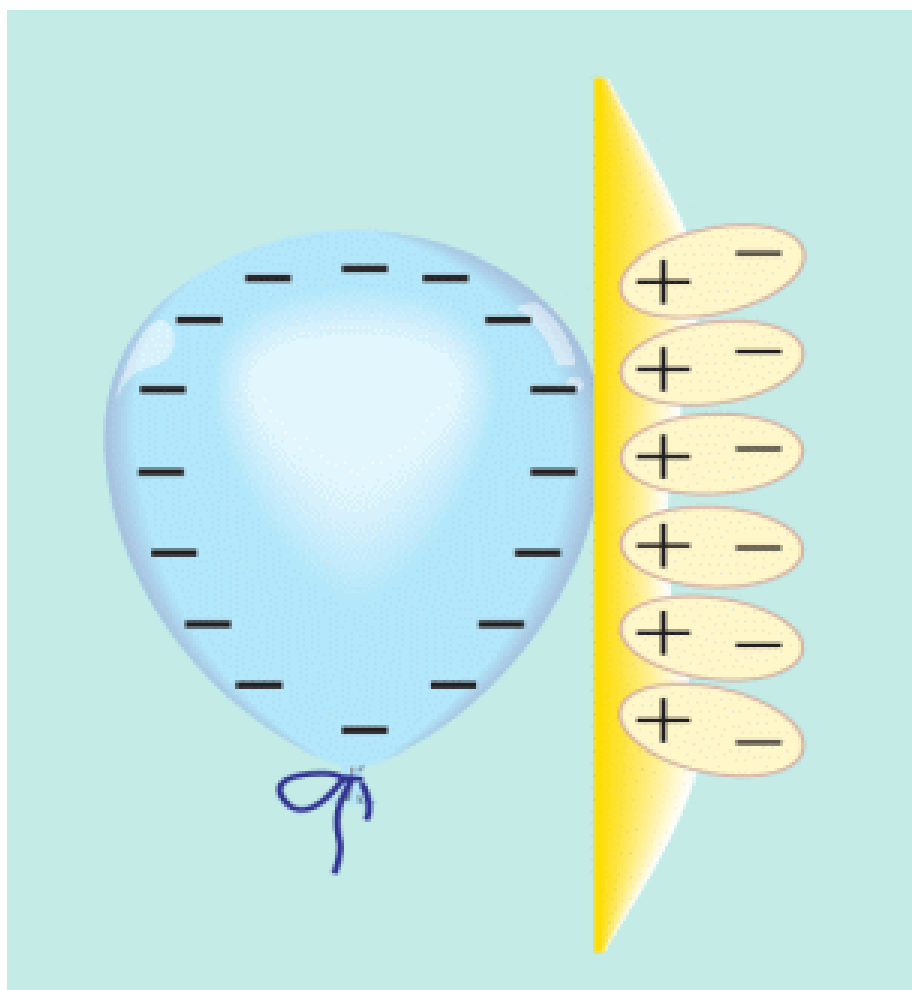

What should you do with balloon to make it stick to the wall, as shown in the picture?

CHARGING BY RUBBING

Бұл әдіс электрленудің негізгі түрі болып табылады. Екі затты бір-біріне үйкеген кезде бірі оң, ал екіншісі теріс заряд алады, Figure 1. Нәтижесінде, екі дене электрленіп, бір-біріне тартылады.

Мысал ретінде, эбонит таяқшасы жүн матасына үйкелген кезде, өз бойына теріс заряд алып, теріс зарядталады. Ал, жүн мата болса, оң зарядталады.

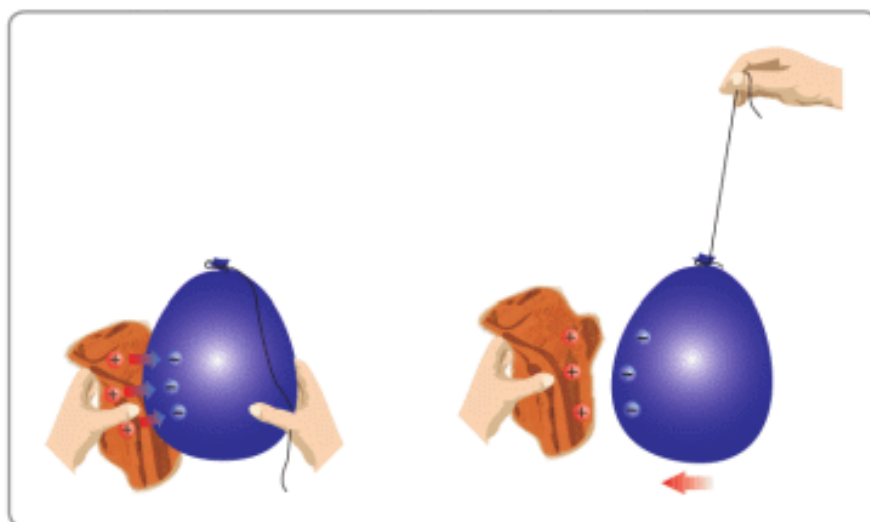

Figure 1

CHARGING BY INDUCTION

Теріс зарядталған эбонит таяқшасын бейтарап сфераға жақындатайық, Figure 2. Электростатикалық күштің әсерінен бейтарап сфераның еркін электрондары сфераның арғы бетіне ығысады. Нәтижесінде сфераның бір жағы оң, екінші жағы теріс электрленеді.

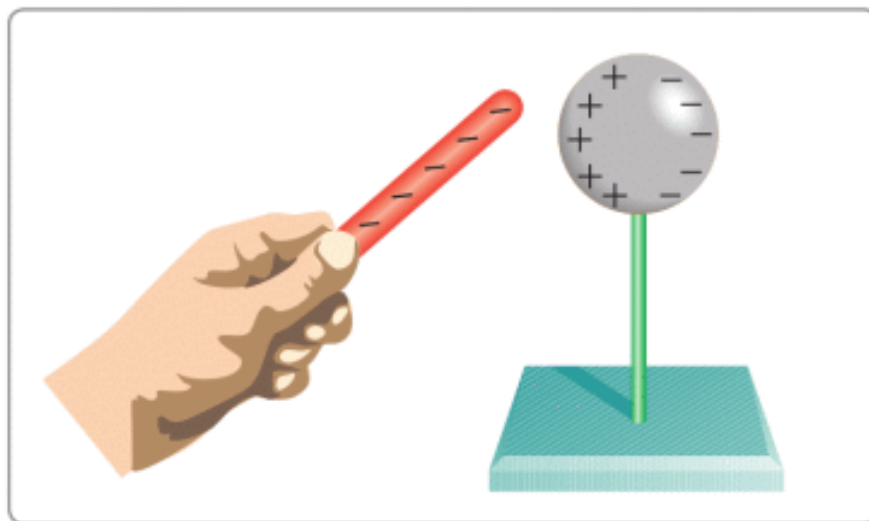

Figure 2

CHARGING BY CONTACT

Егер де, теріс зарядталған және бейтарап денелерді бір-бірімен байланыстырсақ, электрондардың бір бөлігі зарядталған денеден бейтарап денеге ауысады, Figure 3. Егер де, теріс зарядталған дене орнына оң зарядталған дене болса, нәтиже қалай өзгерер еді?

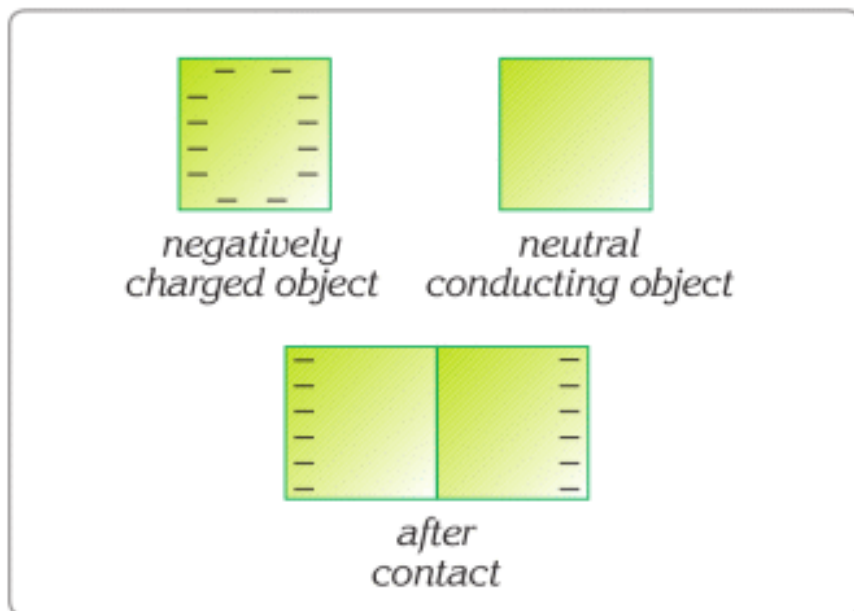

Figure 3

WHAT IS AN ELECTROSCOPE?

Кез келген дененің электрленгенін байқауға арналған аспап электроскоп деп аталады. Figure 4-те көрсетілгендей металл корпус ішінде пластмасса тығын арқылы, ұшына жұқа екі металл тілшелері бекітілген, металл таяқша өткізіледі. Ауа ылғалдылығынан қорғану үшін корпус шынымен қапталады. Металл таяқша корпустан оқшаулағыш затпен бөлінеді.

Электроскоп негізінде бейтарап және оның тілшелері бір-біріне өте жақын орналасқан болады. Егер де, электроскопқа заряд берілсе, металл тілшелер бір-бірінен тебіліп, алшақтайды.

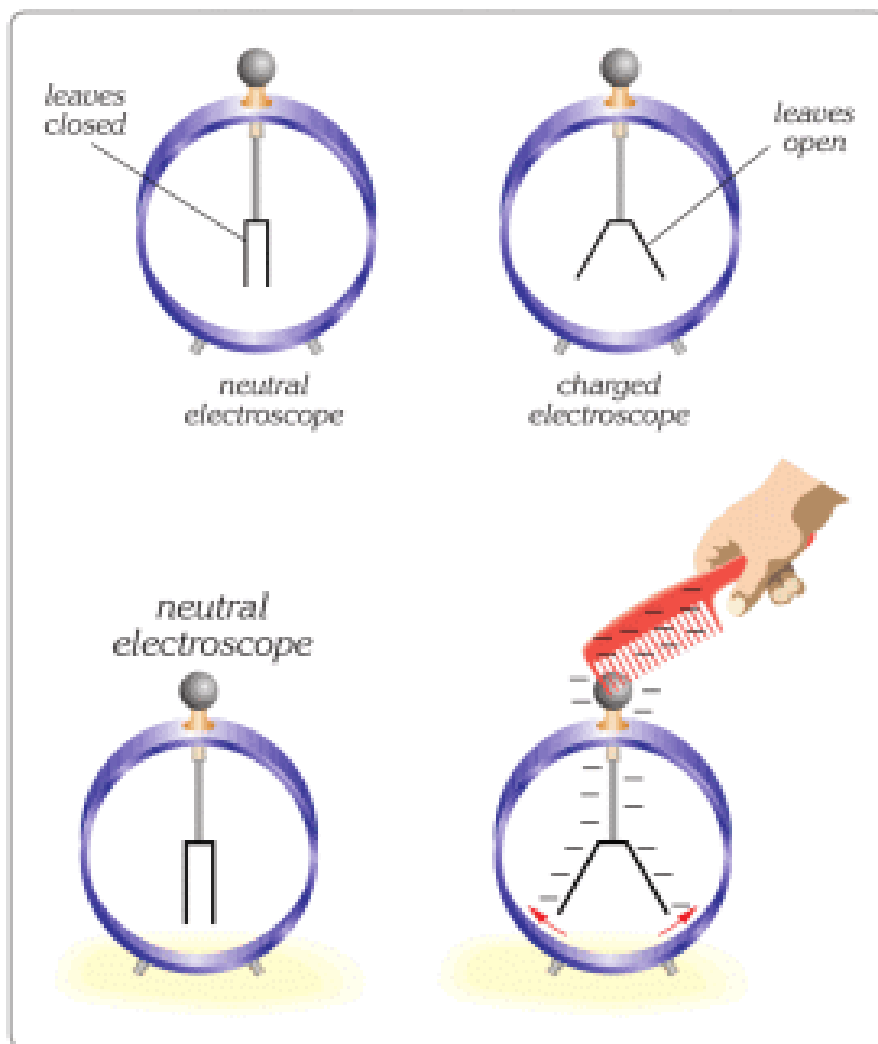

Figure 4

GROUNDING

A charged object can also be grounded using a conducting wire.

For example: if a negative conducting sphere is connected to the earth with a wire, as shown in Figure 5, the extra electrons on the sphere flow to the earth and the sphere becomes neutral.

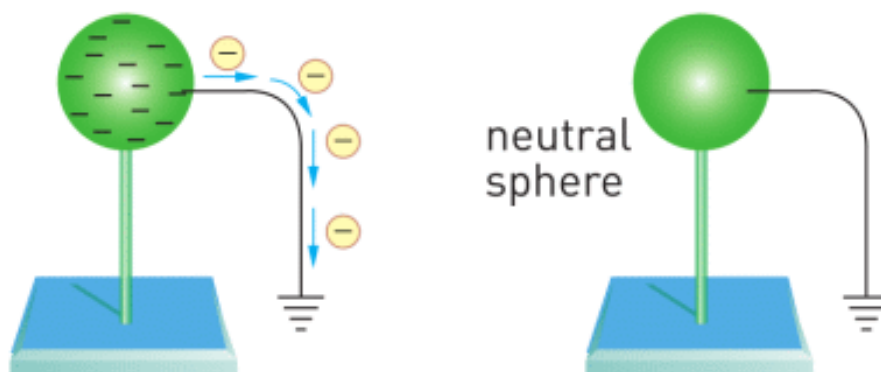

Figure 5

If a positive sphere is grounded, it attracts electrons from the earth through the wire and the sphere becomes neutral, Figure 6.

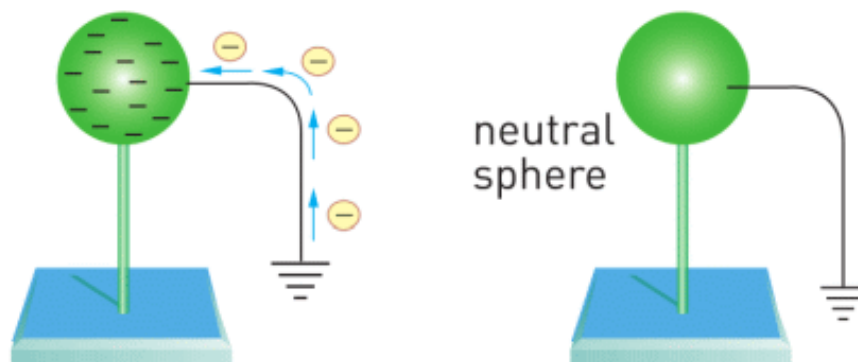
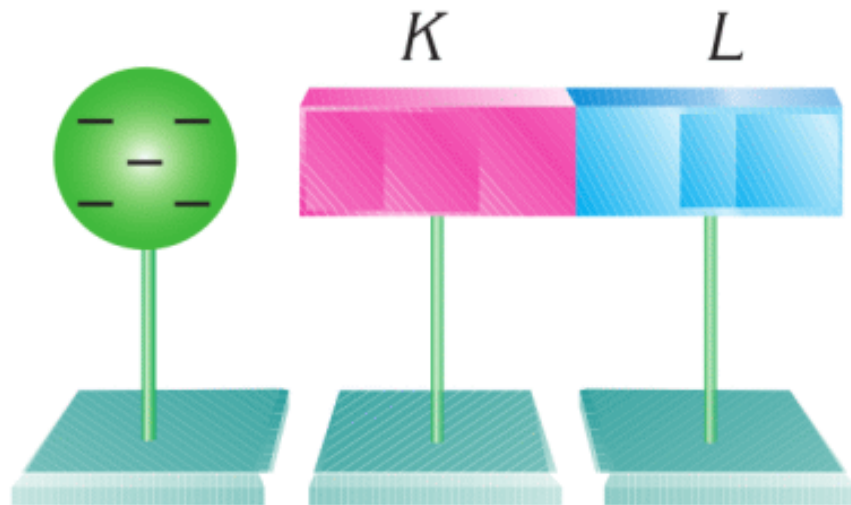

Figure 6

EXAMPLE

A negatively charged object is brought near to neutral objects K and L. What are charges of all objects when K and L are separated?



Solution:

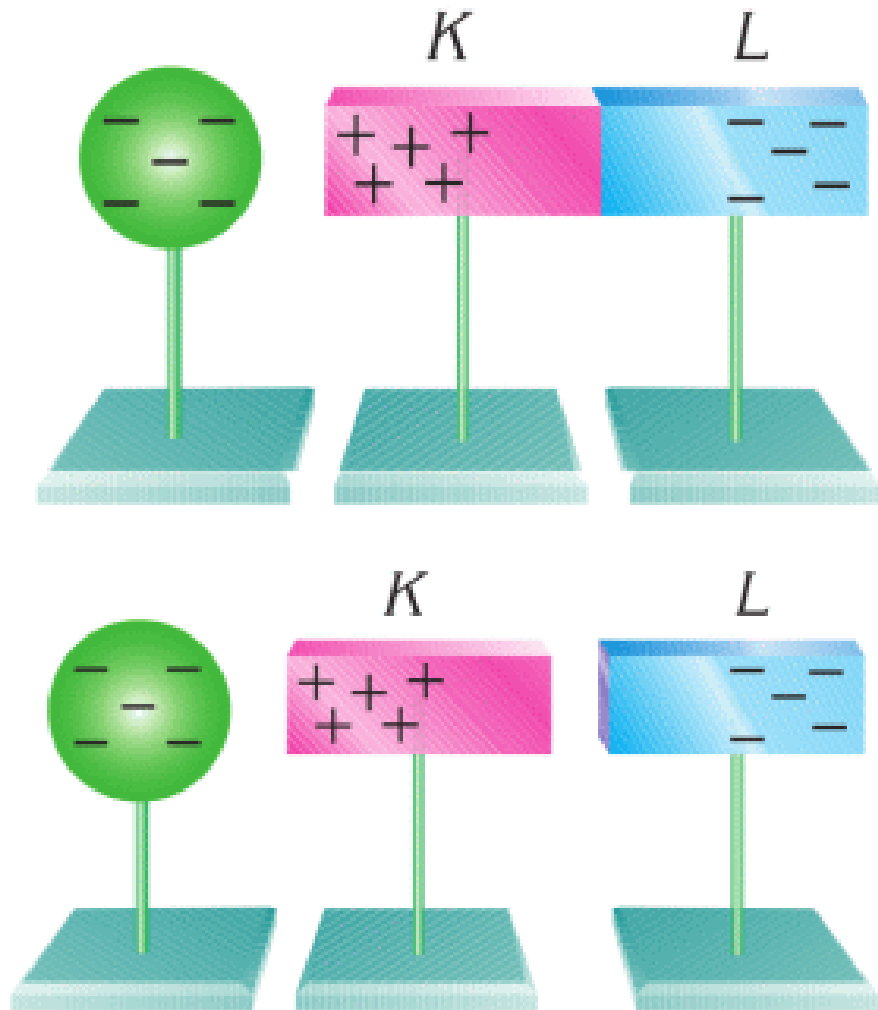

The negative charges of the sphere will repel some electrons from K towards L.

As a result, K will be positively charged, and L - negatively charged.

Then, we separate K and L without moving the sphere. In the end, K carries a positive charge, and L carries a negative charge.

RESEARCH TIME

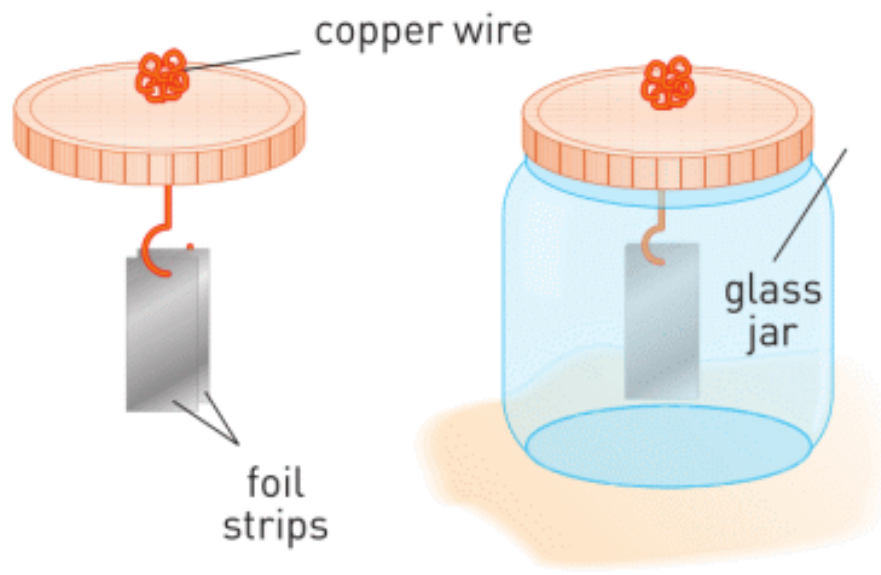

Make simple electroscope and check it.

ACTIVITY

a) Why does the woman feel electric shock?



Why does this happen?

Give more examples.

b) Electric shocks can be dangerous. Why?

What can we do to prevent accidents?



GASOLINE STATION

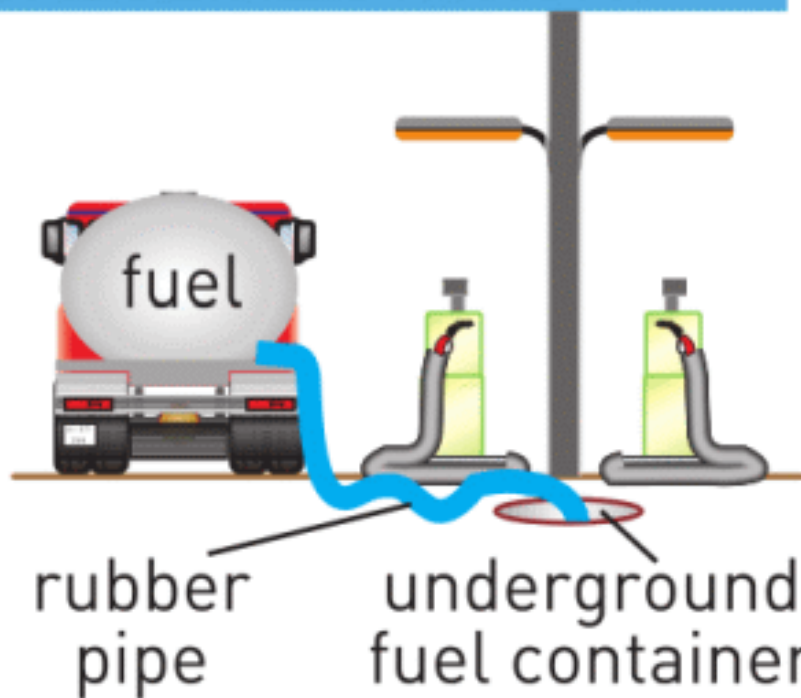

Give more examples.

c) Electrostatics can be useful. How?

Explain pictures below. Give more examples.



Plastic wrap

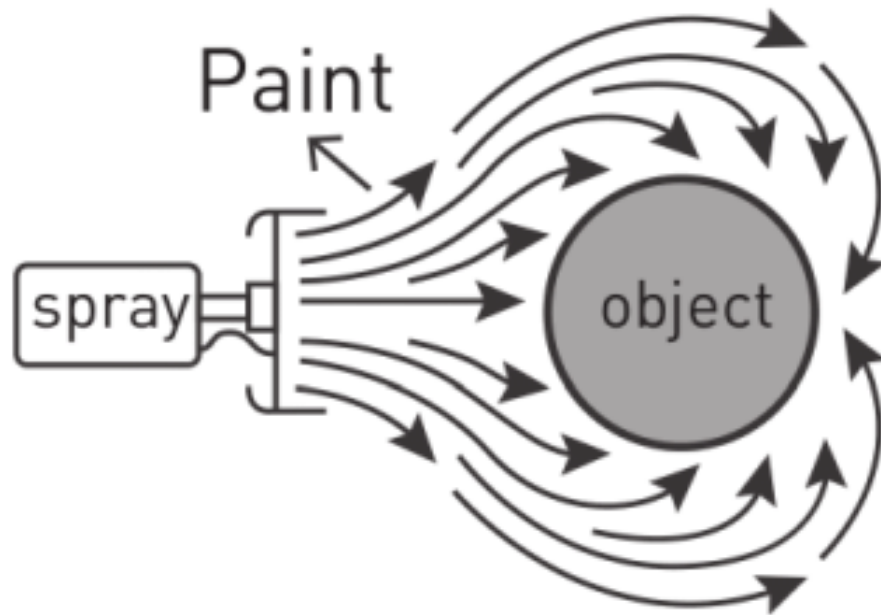

Electrostatic Paint

FACT

Lightning rods.

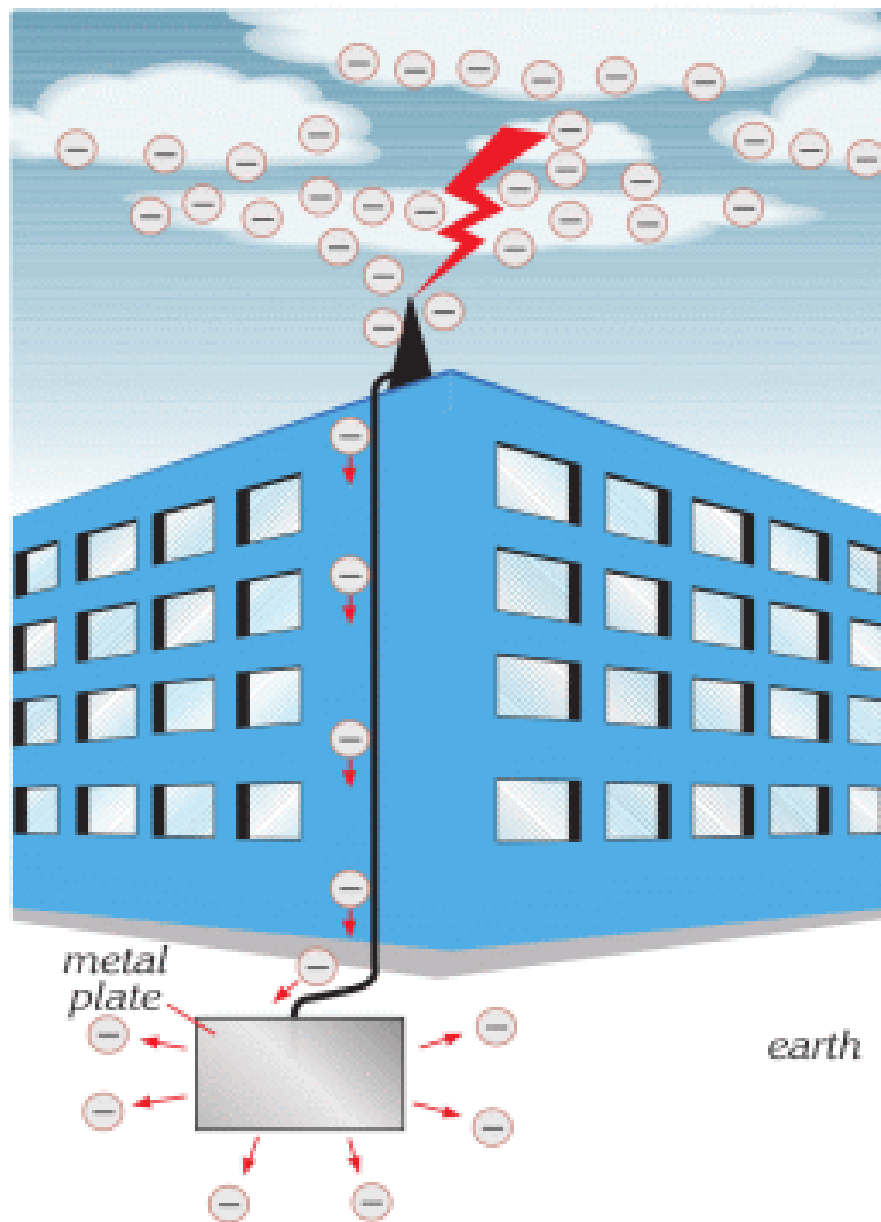

It is a thick conducting wire with one end fixed at the highest point of the building and the other end fixed to a metal plate buried deep in the ground. A lightning rod provides the shortest path for electrons to travel to the ground. In case of a lightning strike, the rod carries charges to the ground without any damage to the building.

LITERACY

1. Describe how you could charge objects. Explain methods to measure charge.
2. Explain methods to discharge objects safely, where grounding can be used.

TERMINOLOGY

- induction - индукция / индукция
- grounding - жерге тұйықтау / заземление
- neutral - бейтарап / нейтральный

4.3 CONSERVATION OF CHARGE. COULOMB'S LAW

YOU WILL:

- - explain law of conservation of charge;
- - apply Coulomb's law for problem solving.

QUESTION



When you comb you hair, sometimes a comb can attract your hair.

Why does this happen?

CONSERVATION OF ELECTRIC CHARGE

Кез келген дененің электрондар саны өте көп. Түсінікті болуы үшін оны белгілі санмен сипаттайық. Мысалы, бір-біріне үйкелетін әуе шары мен жүн матаның бойында 4 "протоннан" және 4 "электроннан" бар деп есептейік, Figure 1.

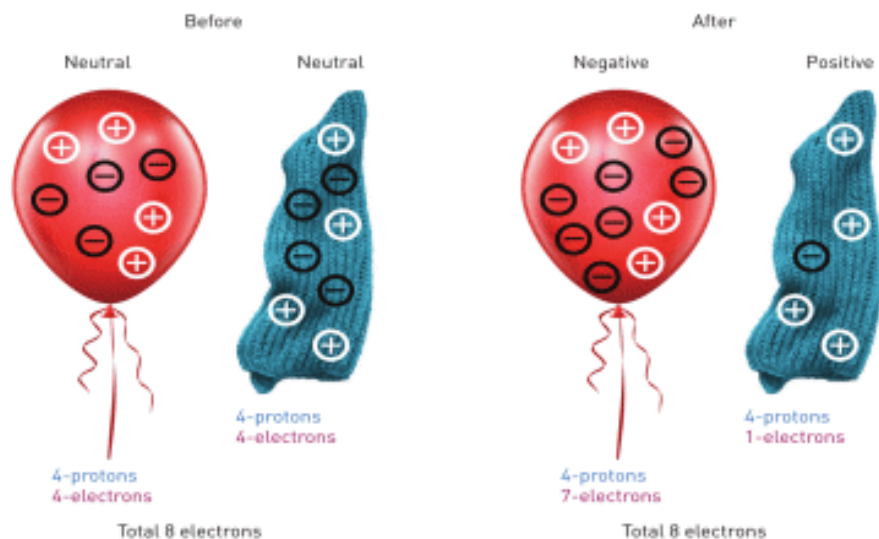

Figure 1. From the picture above, after electrification of balloon, total number of charge will be conserved. 3 "electrons" passed from cloth to balloon, but total number of charges are the same.

We conclude that in any electrification process the sum of the electric charges on both objects is constant. This is known as the law of conservation of electric charge and can be stated as the total amount of electric charge in an isolated system is constant. This is expressed as,

$$q_1 + q_2 + q_3 + \dots + q_n = \text{constant}$$

where q is the symbol for the electric charge on each object in the process. Electric charge is a physical quantity and its SI unit is the Coulomb (C).

INTERACTION BETWEEN CHARGES. COULOMB'S LAW

Зарядтардың арасындағы байланысты алдыңғы тақырыпта қарастырған едік, Figure 2.

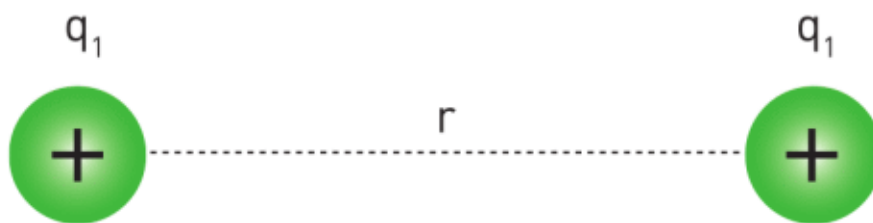

Figure 2

Ал сол зарядтардың арасындағы күшті француз ғалымы Чарльз Кулонның ұсынған, формула арқылы анықтап алуға болады.

$$F = k \frac{|q_1| \times |q_2|}{r^2}$$

F - force between charges. Unit: Newton [N]

q_1 - charge one. Unit: Coulomb [C]

q_2 - charge two. Unit: Coulomb [C]

r - distance between centres of charged objects. Unit: meter [m]

k - constant number: $9 \times 10^9 \text{ N} \cdot \text{m}^2 / \text{C}^2$

1 Кулон өте үлкен шама: 6.3×10^{18} электрон заряды 1 Кулон зарядты құрайды. Материалдар бір - біріне үйкелген кезде, шамамен 1 микрокулон заряд пайда болады.

1 микроКулон = 1 мКл = 10^{-6} Кл = 0.000001 Кл

Табиғаттағы ең кіші заряд ол электронның заряды және ол элементар заряд деп аталады. Электрон e - әрпімен белгіленеді:

$e = -1.6 \times 10^{-19}$ Кл - элементар заряд

Протонның заряды электрондікіне тең, бірақ таңбасы оң.

Any charge of object could be divided to integer number of electrons, so

$$q = n \times e$$

(n - integer number)

IT-LINK

Go to <https://phet.colorado.edu/>

Search “Electric field hockey”

EXAMPLE

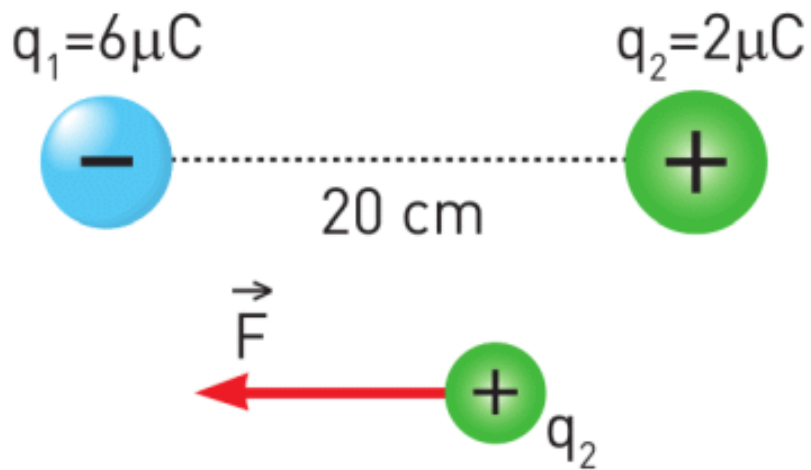

Calculate the force between two charges.

Solution:

$$F = k \frac{|q_1| \times |q_2|}{r^2}$$

$$F = (9 \times 10^9) \frac{(6 \times 10^{-6})(2 \times 10^{-6})}{(2 \times 10^{-1})^2} = 2.7 \text{ N}$$

The force is a vector, so it is directed to each other, for example for second charge; it's directed to the left.

FACT

Electrostatics in bakery.

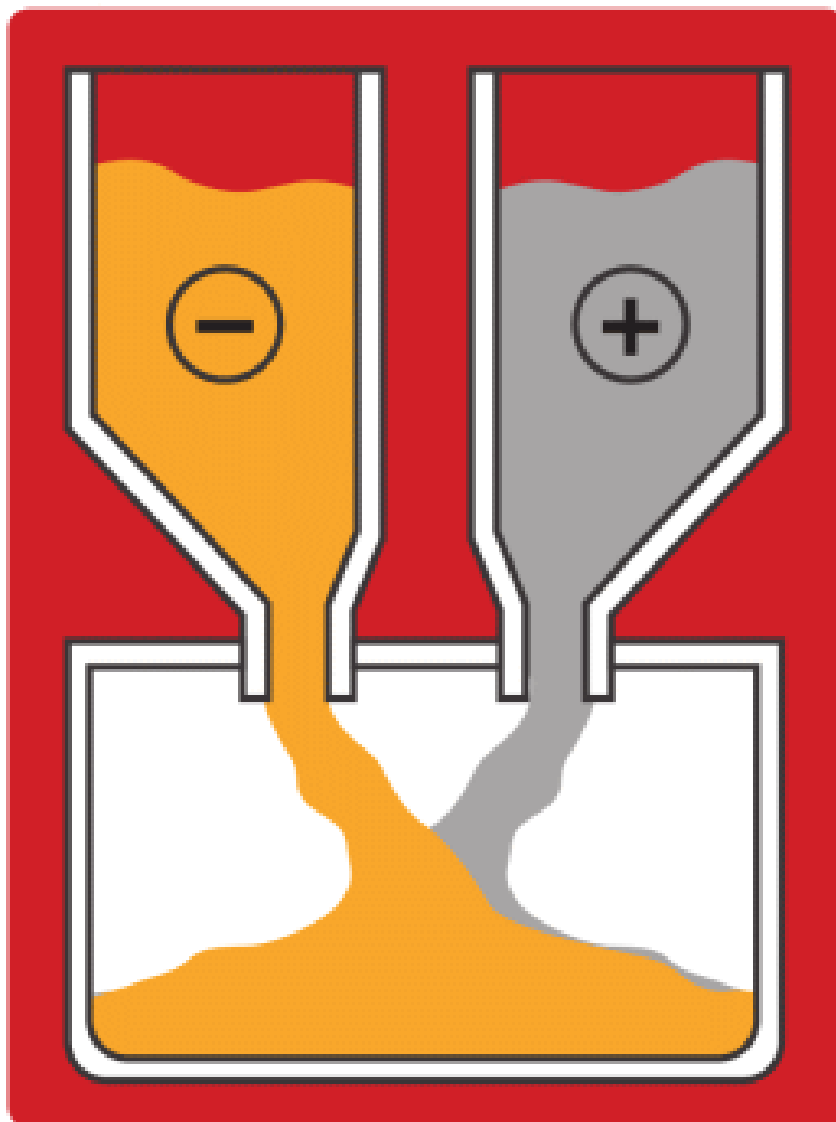

In bakery flour particles are positive. Water droplets are negative. They attract each other and mix.

ART TIME

Make a video that shows attraction and repulsion between charges. Show it to your parents, teachers and friends.

LITERACY

1. You have a neutral balloon and woollen cloth. You rub the balloon with woollen cloth. Balloon becomes negatively charged by -5 nC (nano = 0.000 000 001). What is the charge of the woollen cloth? Is it positive or negative? Why?
2. The 10 nC balloon and 10 nC balloon are on the distance of 1°Cm from each other. Do they pull or push each other? Why? How many Newtons is the electric force? How many grams of load can you lift with this force?

TERMINOLOGY

- to rub – үйкеу / натирать
- wool – жүн / шерсть
- interaction – әрекеттесу / взаимодействие
- bakery – наубайхана / пекарня

4.4 ELECTRIC FIELD. PART 1

YOU WILL:

- - explain physical meaning of "electric field" and determine its dynamics characteristics;
- - calculate force applied on charge by electric field;
- - show electric field by using electric field lines.

QUESTION



What can you do to make a droplet fly?

ELECTRIC FIELD

When we want to move something, we need to push or pull it. In order to apply a force on an object, we must touch it. For example, Figure 1 a.

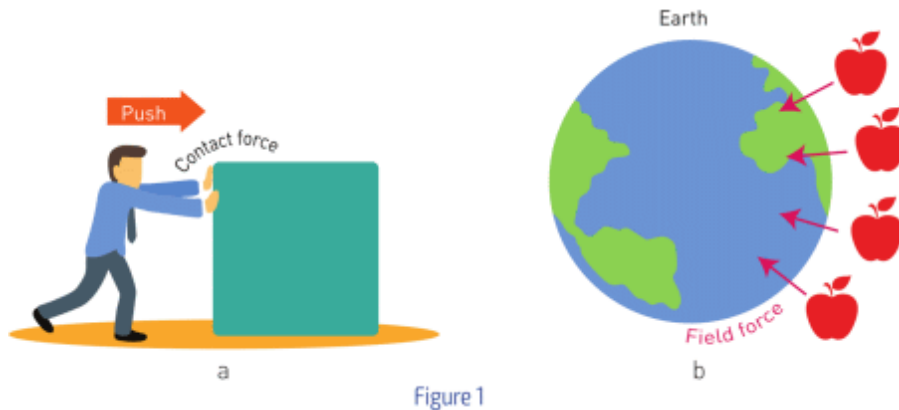

However, the Earth pulls objects with no contact, Figure 1b. Earth has a field that pulls everything. This field is called gravitational field.

Gravitational field produces force – gravitational force.

Similarly, there is no contact between charges when they push (or pull) each other. Charges produce field around them. This field is called electric field. Electric field produces force that is electric force.

Гравитациялық және электр өрістері көзге көрінбейді. Алайда біз бұл өрістерді графикалық түрде суреттей аламыз. Өрісті суреттеу үшін күш сызықтары пайдаланылады. Ол үшін оң зарядтан теріс зарядқа бағытталған сызықтар сызуымыз керек, Figure 2.

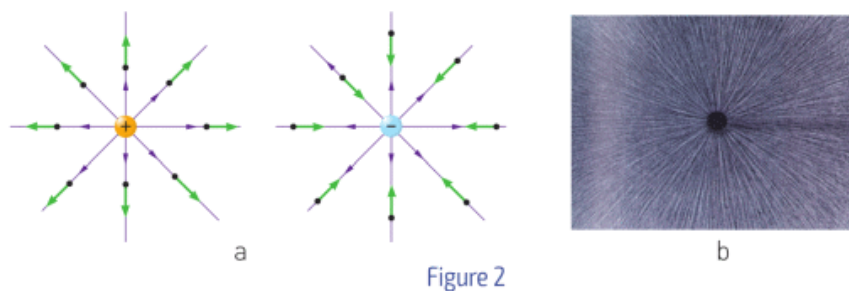

Әр зарядталған дененің айналасында электр өрісі пайда болады.

Егер де, сол өріске зарядталған екінші денені енгізсек, оған бірінші дененің электр өрісінен туындаған күш әсер ете бастайды. Figure 3 а -да көрсетілген $+q$ зарядына назар аударайық.

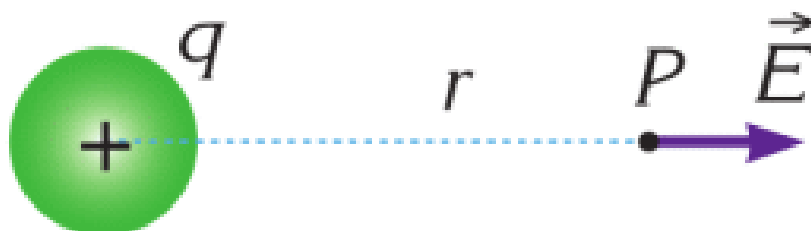
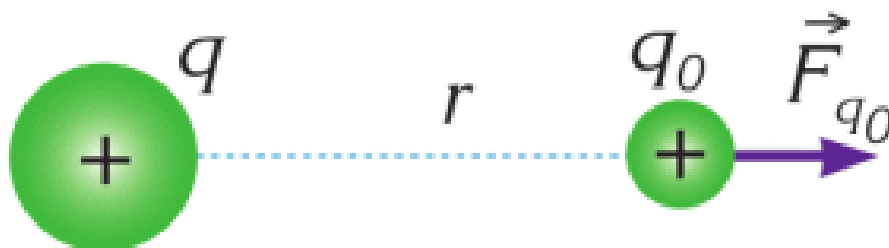

а

Figure 3

Өзінен өте кішкентай заряды бар нүктелік зарядты $+q_0$, $+q$ зарядының электр өрісіне орналастырсақ, $+q$ зарядының электр өрісінің күші нүктелік зарядқа әсер ете

бастайды. Нүктелік зарядтың оң екенін және $+q$ заряд өрісінің жайылуына еш әсер ете алмайтындай кішкентай зарядқа ие екенін естеріңізде сақтаңыздар.

Нүктелік зарядқа әсер еткен күштің сол нүктелік зарядтың өзіне бөлінген кезде, нүктелік зарядтың орналасқан жеріндегі электр өріс кернеулігін анықтаймыз. Сонда:

$$\vec{E} = \frac{\vec{F}_{q_0}}{|q_0|}$$

SI жүйесінде электр өріс кернеулігінің (электр өрісі) өлшем бірлігі Ньютон/Кулон (N/C).

If you put positively charged small object in the field, the field line will show the direction of resultant force. If charge is negative, the direction is opposite.

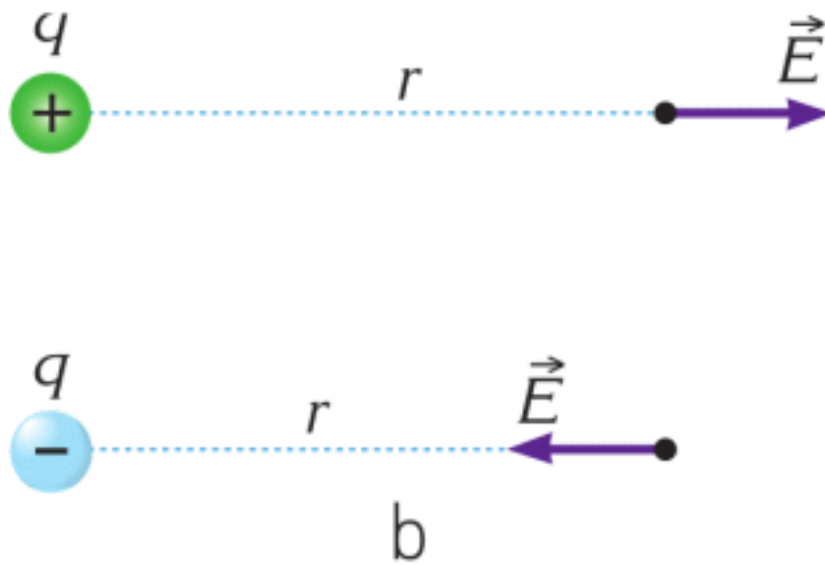

Figure 3

The resultant force acting on charge q placed in electric field can be found using formula:

\vec{F}	=	$ q $	×	\vec{E}
Force		Charge		Electric field
Newtons, [N]		Coulombs [C]		Newton/Coulomb, [N/C]

This formula is analogical to $F = m(\text{mass}) \times g$ (gravity). This is because g means the force acting on each kg of mass, and E means the force acting on each C of charge.

RESEARCH TIME

Go to <https://phet.colorado.edu>

Search

a) "Charges and fields"

b) "Electric field hockey".

What can you say about these simulations?

FACT

"Millikan's experiment"

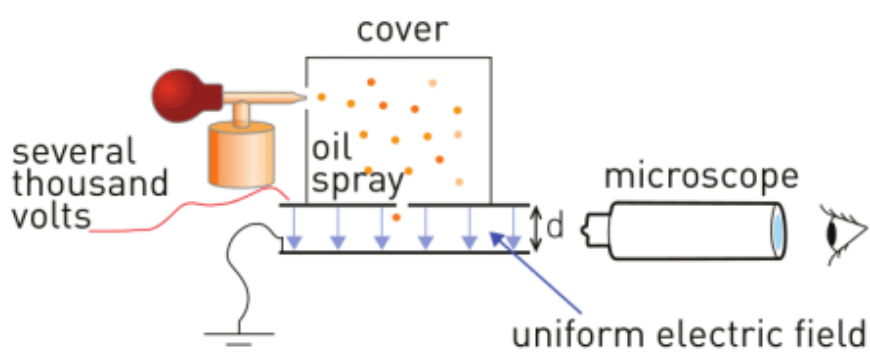

In this experiment oil drops are charged in covered chamber.

Then, oil drops fall into uniform electric field where it could be suspended (gravity balanced with electric force). This experiment helped to find the charge of electron.

EXAMPLE

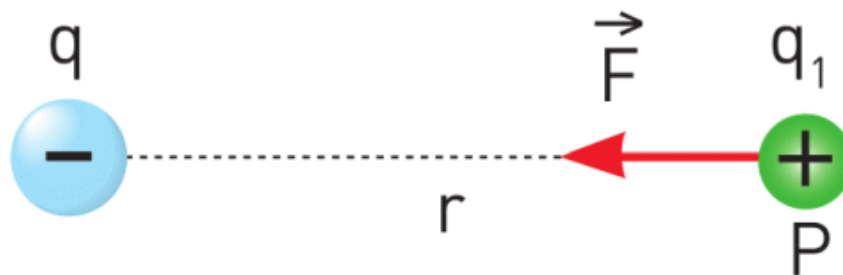

The magnitude of electric field of charge q at point P is 9×10^5 N/C. What force does a charge of $q_1 = +1 \mu\text{C}$ experience if it is placed at point P ?

Solution:

$$F = |q_1| \times E = 10^{-6} \text{C} \times 9 \times 10^5 \frac{\text{N}}{\text{C}} = 0.9 \text{N}$$

ART TIME

Make “Kelvin water dropper”. Make it and show to your parents, teachers and friends.

LITERACY

1. Why you are not able to push or pull objects on a distance (without touching them)? Why can charges and magnets pull or push on a distance?
2. You push wall with your hand. Do atoms of your hand and atoms of wall touch each other? Explain your answer.
3. Can you fly? No, you cannot, but electricity can help you overcome gravity. What should your charge be so you can overcome the gravity? Electric field of the Earth is about 130 N/C.

TERMINOLOGY

- field – өріс / поле attraction – тартылыс / притяжение
- repulsion – тебіліс / отталкивание

4.5 ELECTRIC FIELD. PART 2

YOU WILL:

- - show electric field using electric field lines.

QUESTION

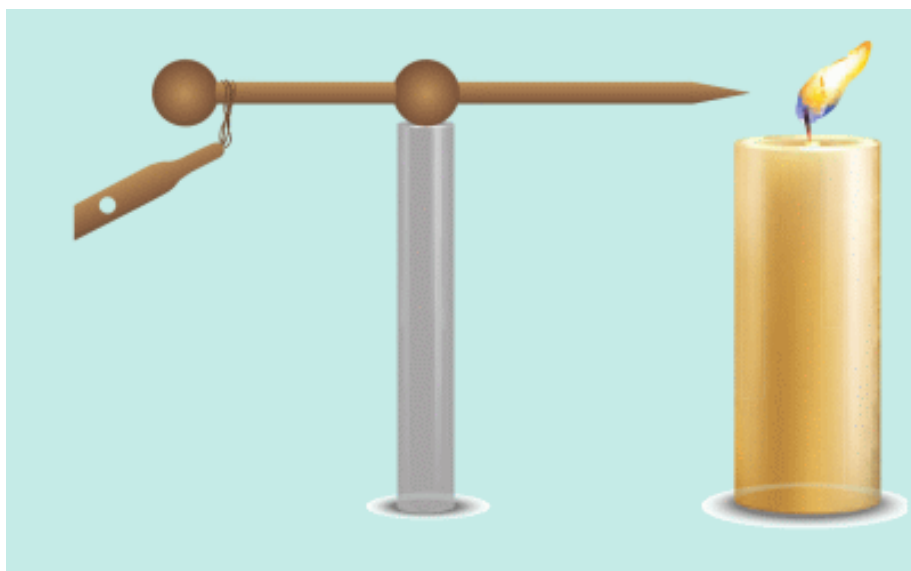

“Ion wind” - an effect at which you can influence an object at distance by electricity. It can even put off a fire of candle. Try to explain this.

ELECTRIC FIELD

Зарядталған дененің тудырған электр өрісінің кернеулігі векторлық шама болып табылады. Оның бағыты сол өрістегі оң сынақ зарядына әсер ететін электрлік күші бағытында болады. Басқа да вектор шамалары секілді

электр өрісі кернеулігі де көрсеткіш оқпен (an arrow) белгіленеді.

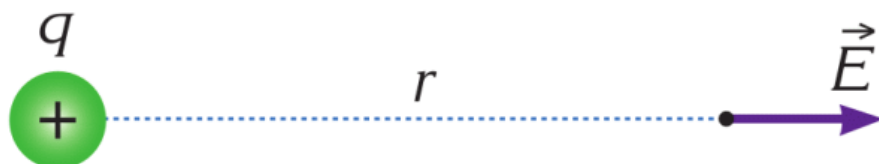

Оның мәні зарядқа әсер ететін күштің сол зарядқа қатынасына тең. Нүктелік зарядтың тудыратын электр өрісінің кернеулігін төмендегі формула арқылы табуға болады:

$$\vec{E} = k \frac{|q|}{r^2}$$

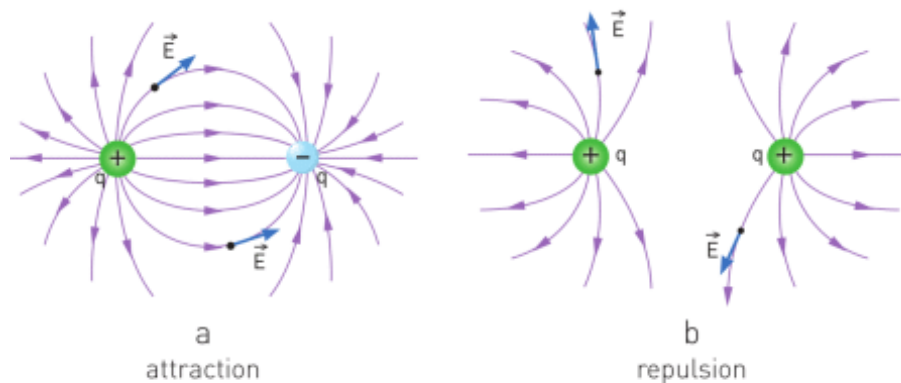

Figure 1

THE SUPERPOSITION PRINCIPLE

Электр өрісі кернеулігін қосуға немесе азайтуға болады. Бір жерде екі немесе одан да көп заряд болса, кез келген нүктедегі электр өрісі кернеулігінің мәнін табу үшін векторларды қосу әдісі қолданылады:

$$\vec{E} = \vec{E}_1 + \vec{E}_2 + \dots + \vec{E}_n$$

UNIFORM ELECTRIC FIELD

Біртекті электр өрісі кернеулігі екі қарама-қарсы зарядталған жазық металл пластиналар арасында болады.

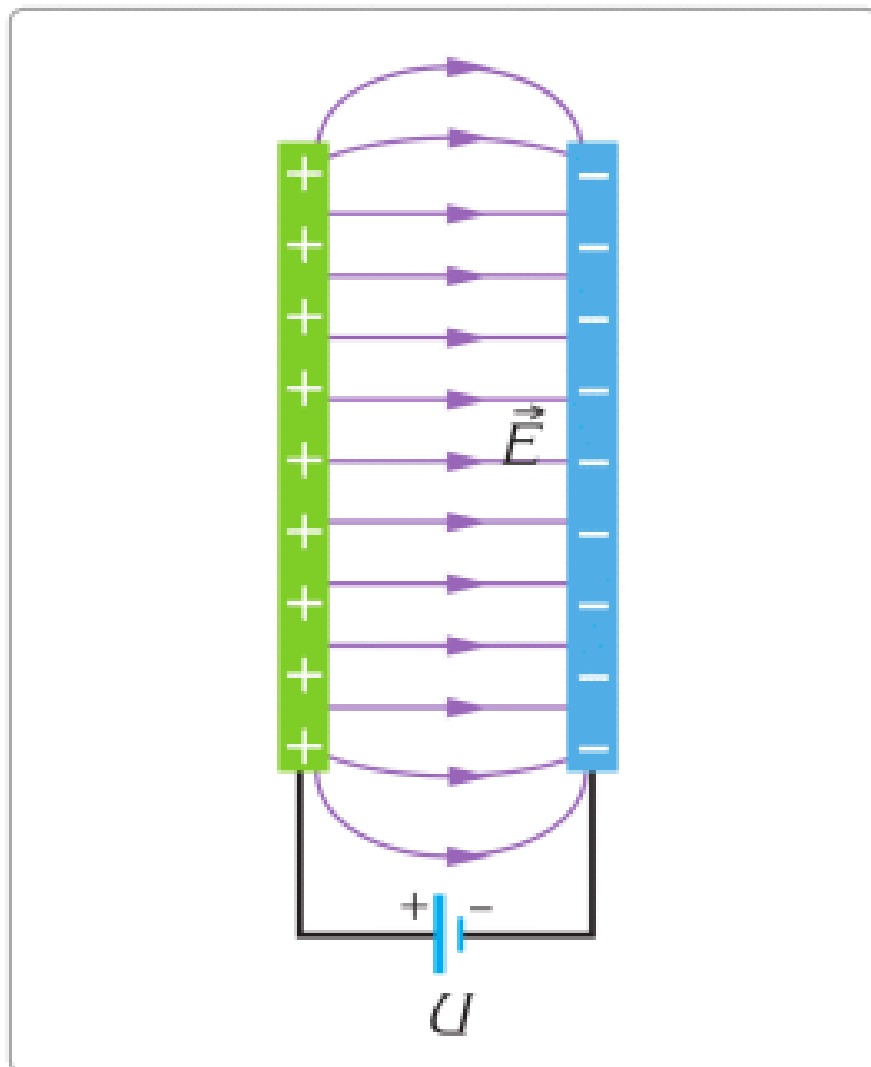
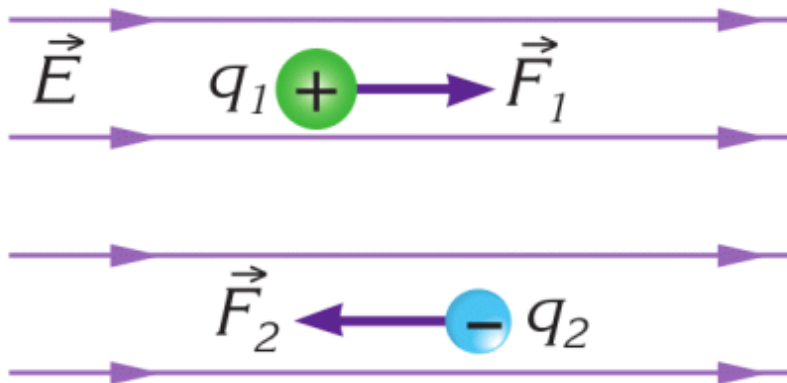

Figure 3

Осы пластиналар арасындағы электр өрісі кернеулік сызықтары бір-біріне параллель және бағыты мен мәні бірдей болады, Figure 3. Осыған қоса өріс біртекті болғандықтан зарядқа әсер ететін күш те сол аумақта бірдей болады.



EXAMPLE



The resultant electric field at point P due to the fixed charges q_1 and q_2 is zero.

What is the ratio q_1/q_2 ?

Solution:

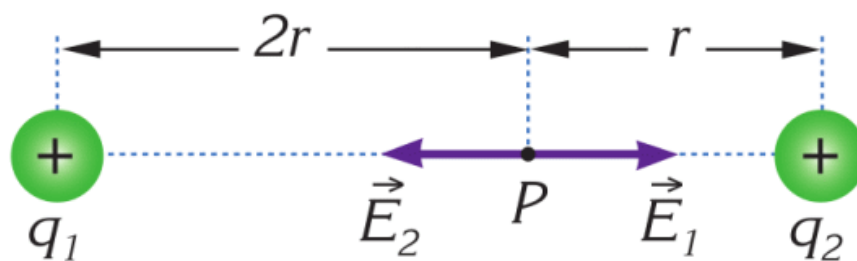

Since the net electric field at point P is zero, the electric field produced by q_1 and q_2 are equal in magnitude but opposite in direction.

So, the signs of both charges must be the same. Let us say they are both positive. The magnitude of the electric field produced by q_1 at point P is

$$E_1 = k \frac{|q_1|}{(2r)^2} \text{ and of } q_2 \quad E_2 = k \frac{|q_2|}{r^2}$$

$$\text{since } E_1 = E_2, \quad k \frac{|q_1|}{4r^2} = k \frac{|q_2|}{r^2}$$

$$\text{Therefore, } \frac{|q_1|}{|q_2|} = 4$$

RESEARCH TIME

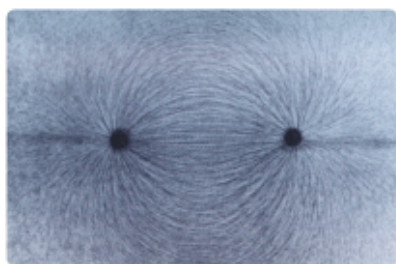

When lines connect,
there is an attraction.

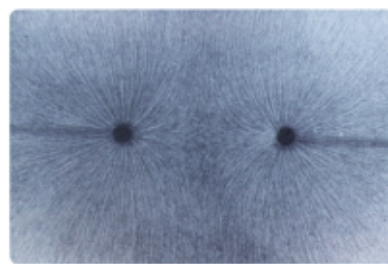

When lines do not connect,
these is a repulsion.

Figure 2

Make research about how you can represent electric field lines with hair and oil. Similar demonstration represented on Figure 2.

FACT

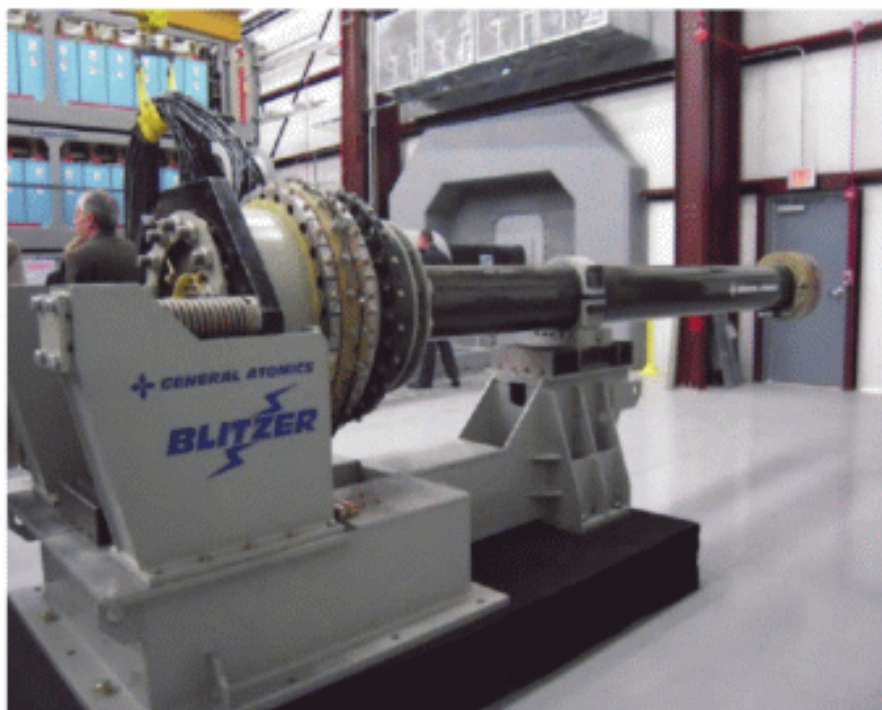

Electromagnetic gun destroys any technical device with electric field without damage to people.

LITERACY

1. Determine the electric field at point P a distance 20 cm from the negatively charged particle $q = -4 \mu\text{C}$. What force does a charge of $q_1 = +1 \mu\text{C}$ experience if it is placed at point P?

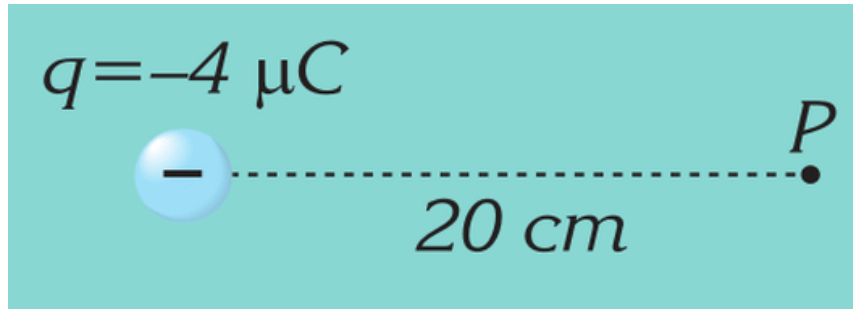

2. Strong electric field affect all objects around, and even could make damage. How?
3. Determine the electric force acting on a point charge of $q = 2 \mu\text{C}$, that is placed in a uniform electric field of $E = 10^5 \text{ N/C}$.
4. If the electric field at point P is zero, what is the ratio of distances r_1 and r_2 ?



TERMINOLOGY

- superposition – суперпозиция / суперпозиция
- net field – қорытқы өріс / суммарное поле
- fixed – бекітілген / закрепленный

4.6 ELECTRIC POTENTIAL. POTENTIAL DIFFERENCE

YOU WILL:

- - explain physical meaning of electric potential and potential difference.

QUESTION

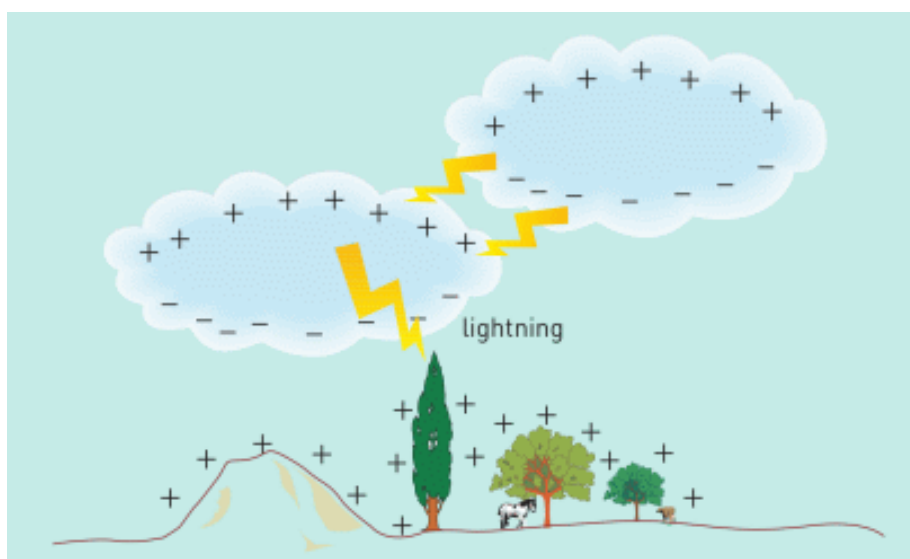

Why does lightning strike the ground?

ELECTRIC POTENTIAL. POTENTIAL DIFFERENCE

Егер де А нүктесінен алма жіберілсе, онда оның В нүктесіне жетерде кинетикалық энергиясы болады. Дәл солай, С нүктесінен теріс заряд жіберілсе, D нүктесіне

жетерде оның да кинетикалық энергиясы болады, Figure 1 а.

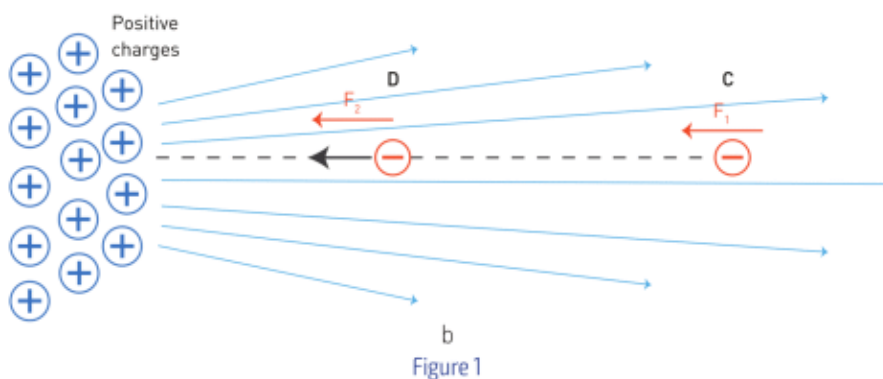
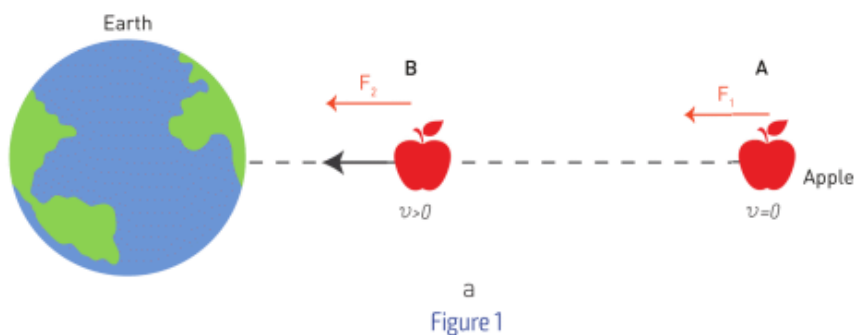

Алманың жылдамдығы екі нүкте (А мен В) арасындағы гравитациялық потенциал энергиялар айырмашылығынан туындайды.

Ал екінші жағдайдағы теріс зарядтың жылдамдығы, сол екі нүкте (D мен C) арасындағы электр потенциал энергиялар айырмашылығынан туындайды.

СИ жүйесінде кез келген екі заряд (q мен q_0) арасындағы потенциалдық энергия төменде көрсетілген формула арқылы табылады (Figure 2 а):

$$E_p = k \frac{q \times q_0}{r}$$

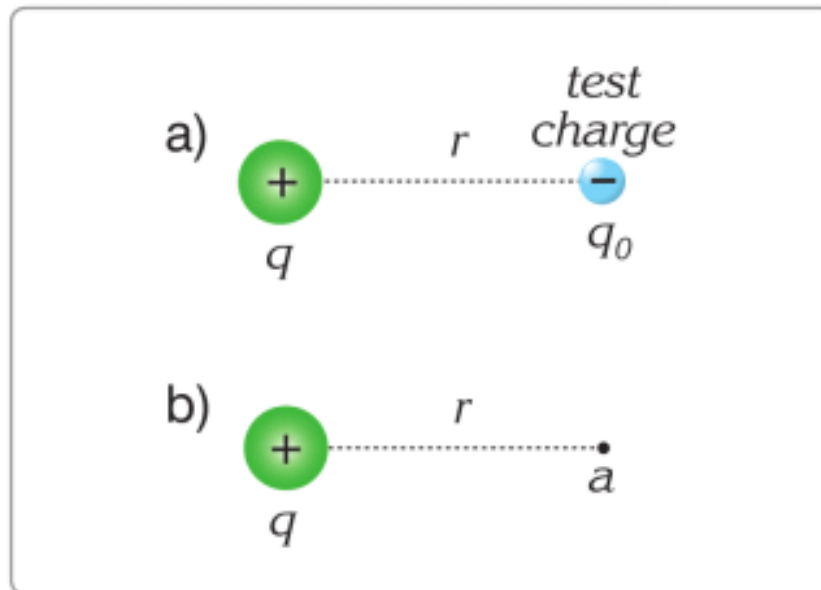

Figure 2

We generally need to know the ratio of electric potential energy to the charge. This ratio is called electric potential. We use ϕ for electric potential. The electric potential at a point a, shown in Figure 2 b, where the test charge was placed is denoted by ϕ_a . Hence,

$$\varphi_a = \frac{E_p}{q_0} = \frac{k \frac{q \times q_0}{r}}{q_0} \Rightarrow \varphi_a = k \frac{q}{r}$$

Note that the electric potential of the charge q at point a is independent of the test charge. Electric potential is a scalar quantity. The SI unit of electric potential is the Joule/Coulomb and is given the special name of the Volt, (V), in honour of Alessandro Volta, the inventor of the electric battery. Then

$$1 \text{ V} = 1 \text{ J/C}$$

On the Figure 1 b, Point D has high electric potential ϕ_D , and point C has low electric potential ϕ_C . Electric potential energy difference depends on the difference $\phi_D - \phi_C$. The difference ($\phi_D - \phi_C$) is called potential difference.

9 Volts and 12 Volts mean that they give 9 J and 12 J or energy to move 1C of charge. If they push 3C of charge, they give 27J and 36J of energy, Figure 3. That means 12 Volts battery is “stronger” than 9 Volts battery.

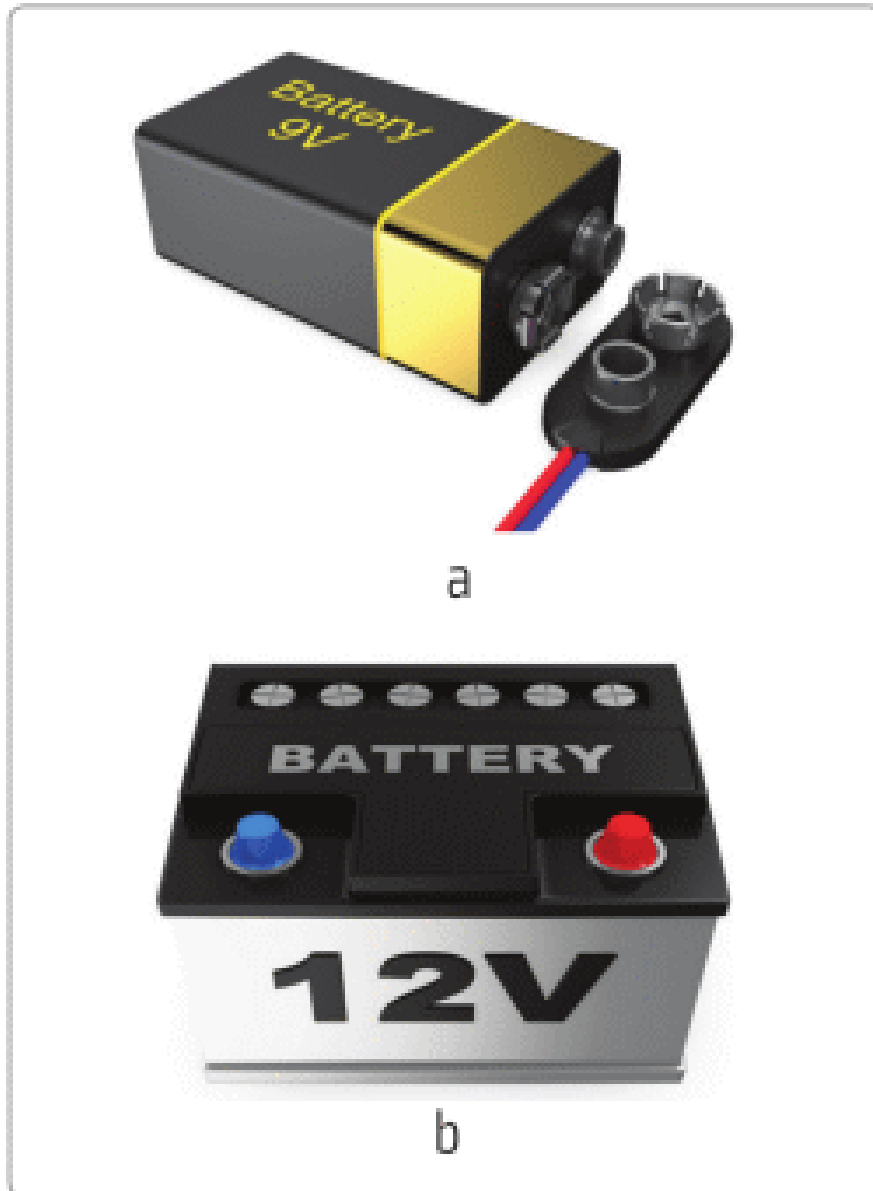

Figure 3

The potential difference can be denoted as $\Delta\phi$ or U which represents

$$U = - \Delta\varphi = \varphi_D - \varphi_C$$

Note that φ_D is the potential at the final point D and φ_C is the potential at the initial point C. We know that

$$\varphi_C = \frac{E_{P \text{ at } C}}{q} \quad \text{and} \quad \varphi_D = \frac{E_{P \text{ at } D}}{q}$$

where $E_{P \text{ at } C}$ and $E_{P \text{ at } D}$ are the electric potential energies at the points C and D, respectively. By substituting these into the formula

$$U = \varphi_D - \varphi_C = \frac{E_{P \text{ at } D}}{q} - \frac{E_{P \text{ at } C}}{q} \Rightarrow U = \frac{\Delta E_p}{q}$$

As the charge is moved from the initial point A to the final point B, by an external force, it does positive work against the electric force. The electric potential energy of the charge increases. We can write

$$\Delta E_p = W_{CD} \Rightarrow U = \frac{W_{CD}}{q}$$

In short, potential difference is defined as work per unit charge (or change in potential energy per unit charge).

The SI unit of potential difference is the Volt (V), for this reason potential difference is also called voltage.

DISCUSSION

How would you determine terminals of battery if + and - signs are erased?

EXAMPLE

Find the potential energy of a system of point charges of $q_1 = 20 \mu\text{C}$ and $q_2 = -10 \mu\text{C}$ when they are $r_1 = 20 \text{ cm}$ apart.

Solution:

$$E_p = k \frac{q_1 \times q_2}{r_1} = 9 \times 10^9 \frac{\text{Nm}^2}{\text{C}^2} \frac{(20 \times 10^{-6}\text{C}) \times (-10 \times 10^{-6}\text{C})}{(0.2\text{m})} = -9 \text{ J}$$

LITERACY

1. How does the electric potential energy of a charged object change if it moves: a) perpendicular to the direction of; b) in the same direction as; c) in the opposite direction to the Coulomb force acting upon it?
2. When a positively charged particle moves in a direction parallel to the electric field, how does its electric potential energy and electric potential change? Which force is doing positive work?

3. You saw lightning many times. Did you know that clouds and Earth form capacitor? Potential of earth -50000 Volts and potential of sky is 200000 Volts. Find potential difference.

ART TIME

How would you illustrate the meaning of the word “potential”?

TERMINOLOGY

- to gain – алу / получать
- ratio – қатынасы / соотношение

4.7 CAPACITANCE & CAPACITORS

YOU WILL:

- - describe structure of capacitor and its function.

QUESTION



Look at the picture of camera's flash. How do you think the flash works?

CAPACITANCE & CAPACITORS

Кейбір құрылғылар (өткізгіштер) электр зарядын жинақтай алады. Осындай құрылғыларды конденсатор деп атаймыз. Ең қарапайым конденсатор бір-бірінен

оқшауланған екі параллель жазық металл пластинадан тұрады. Егер оларды батареяға жалғасақ, бір пластинасы оң болып, екіншісі теріс болып зарядталады, Figure 1. Конденсаторға түсірілген потенциал айырымы (кернеуі) қаншалықты артса, олардың бойында жинақтай алатын заряд мөлшері соншалықты артады. Демек, конденсатор зарядының кернеуге катынасы тұрақты болып табылады.

$$C = \frac{q}{U}$$

Осы тұрақты конденсатор электрсыйымдылығы деп аталады.

C - электрсыйымдылық,

q - пластинаның біреуіндегі зарядтың абсолют шамасы,

U-кернеу.

Конденсатор электрсыымдылығының СИ жүйесіндегі бірлігі 1 фарад (Ф) болып табылады,

$$1 \text{ Ф} = 1 \text{ Кл/В}$$

Көбінесе конденсаторлардың электрсыымдылығын көрсету үшін микрофарад (мкФ), нанофарад (нФ) және пикофарад (пФ) қолданылады.

$$1 \text{ мкФ} = 10^{-6} \text{ Ф}$$

$$1 \text{ нФ} = 10^{-9} \text{ Ф}$$

$$1 \text{ пФ} = 10^{-12} \text{ Ф}$$

Capacitors are used in computers, smartphones and other electronic devices.

The simplest capacitor consists of two metal plates. Battery charges capacitor, Figure 1 a. Then plates can store charges, Figure 1 b. Then it can give electricity for a very short time, Figure 1 c. The lamp gives short flash, and then it fades.

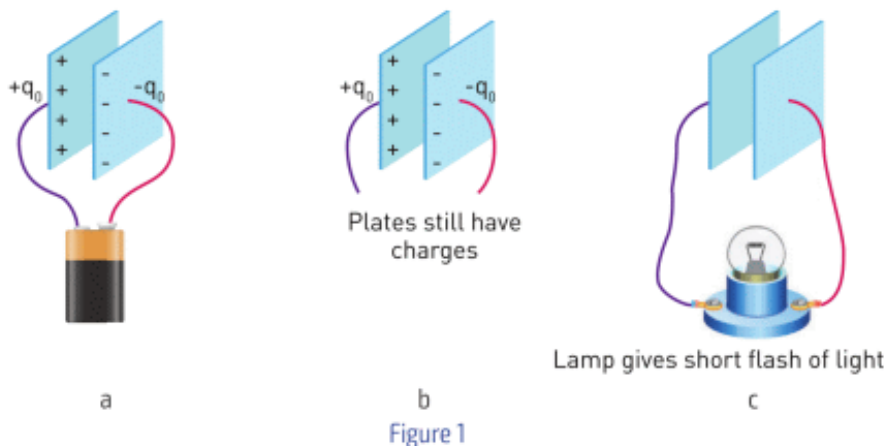

PARALLEL PLATE CAPACITORS

Жазық конденсаторлар ауданы S , арақашықтығы d екі жазық металл пластинадан тұрады, Figure 2.

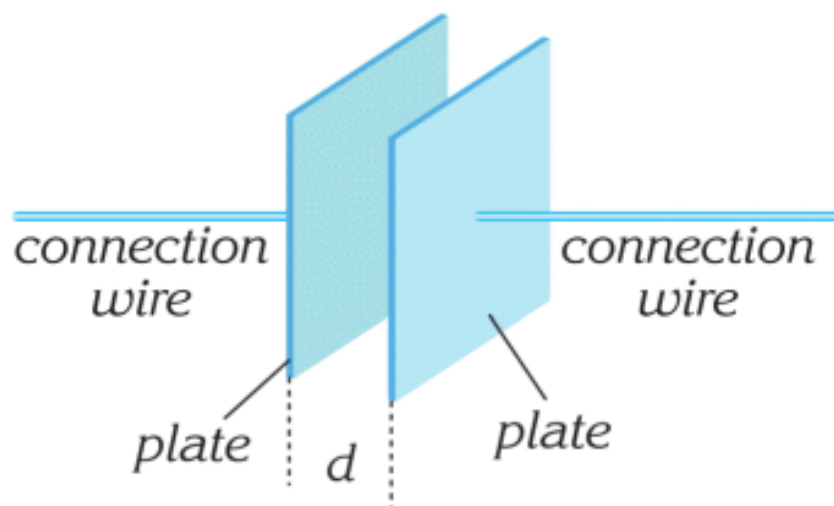

Figure 2

Конденсатор заряды бір пластинасындағы заряд мөлшеріне тең.

Figure 3 a конденсаторды зарядтау жолын көрсетеді.

Зарядталғаннан кейін екі пластина арасында біртекті электр өрісі пайда болады, Figure 3 b and Figure 3 c.

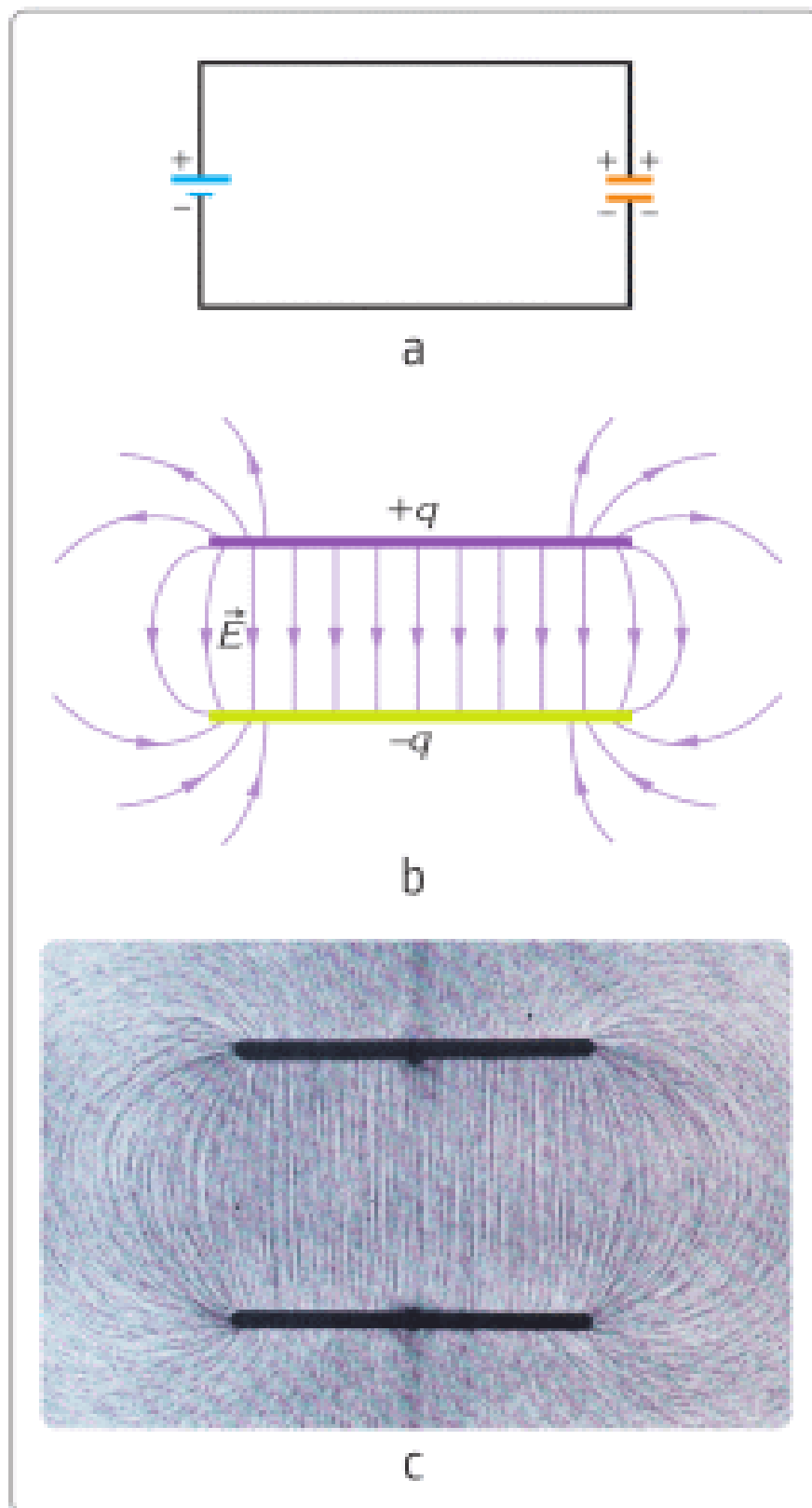

Figure 3

Жазық конденсатордың электрсыйымдылығы:

- Пластиналар арасындағы диэлектрик (ток өткізбейтін зат) өтімділігі тұрақтысына, ε , және электр тұрақтысына, $\varepsilon_0=8.85 \times 10^{-12}$ Фарад/метр.

- Пластина ауданына, S , тура пропорционал.

- Пластиналар арақашықтығына, d , кері пропорционал.

$$C = \varepsilon_0 \varepsilon \frac{S}{d}$$

Конденсаторлардың басқа да пішіндері кездеседі, мысалы, цилиндрлік және сфералық конденсаторлар.

ФАКТ

"Ust-Kamenogorsk Capacitor Plant" was established in 1959. It is the only plant in Kazakhstan that produces capacitors.

ФАКТ

Touchscreen.

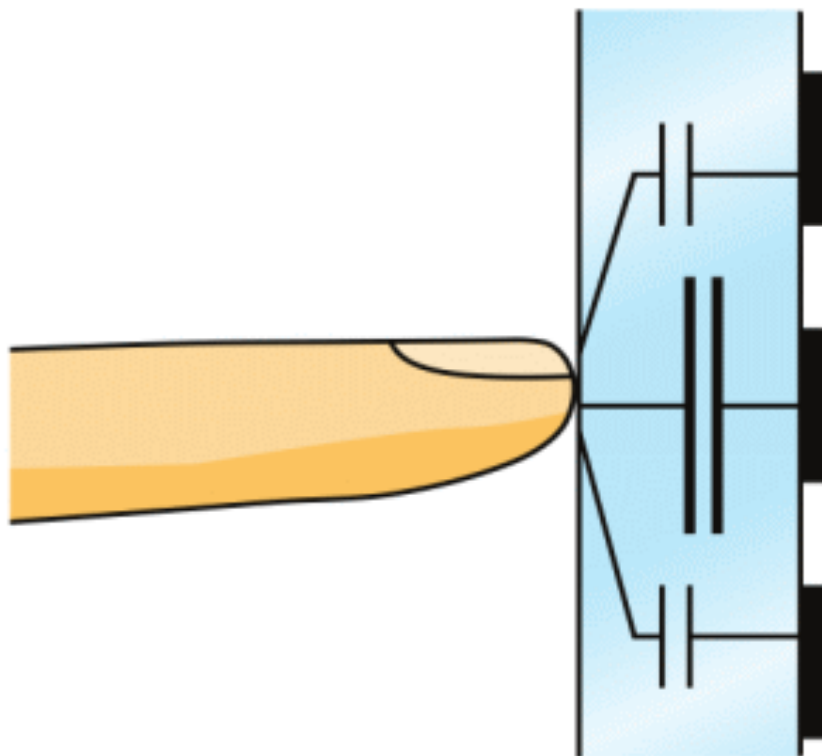

There is a grid of electrodes on the inner side of the screen. This electrode with a human body forms a capacitor. Electronics measure a capacity of capacitors.

RESEARCH TIME

You can build a simple capacitor. It is called “Leiden jar”.

EXAMPLE

Camera flash has a capacitor. Capacitor stores charge at 300 Volts. Then capacitor loses half of the charge. What is the voltage of the capacitor?

Solution:

Charge decreases two times. That means voltage decreases two times. Voltage is 150 Volts.

EXAMPLE

A parallel plate capacitor of capacitance $4 \mu\text{F}$, carries a charge of $60 \mu\text{C}$. What is the potential difference between the plates of the capacitor?

Solution:

$$\text{From } C = \frac{q}{U}, \text{ we can write, } U = \frac{q}{C}. \text{ Substituting in the values, } U = \frac{60 \mu\text{C}}{4 \mu\text{F}} = 15\text{V}$$

LITERACY

1. How many Volts do you get from electrical socket? How many Volts do you get from AA battery? Why are they different?
2. When you run a lot of programs on a computer, its capacitors work fast. Why?
3. A parallel plate capacitor of capacitance $20 \mu\text{F}$, carries a charge of $10 \mu\text{C}$. What is the potential difference between the plates of the capacitor?
4. How can you make capacitor that stores lightning?

ART TIME

Make theatre play that explains “lightning” and show it to your parents, teachers and friends.

TERMINOLOGY

- to store – сақтау / хранить
- electric capacitance – электр сыйымдылық / электрическая емкость

SUMMARY

- Atom consists of 3 main particles: protons, neutrons, and electrons.

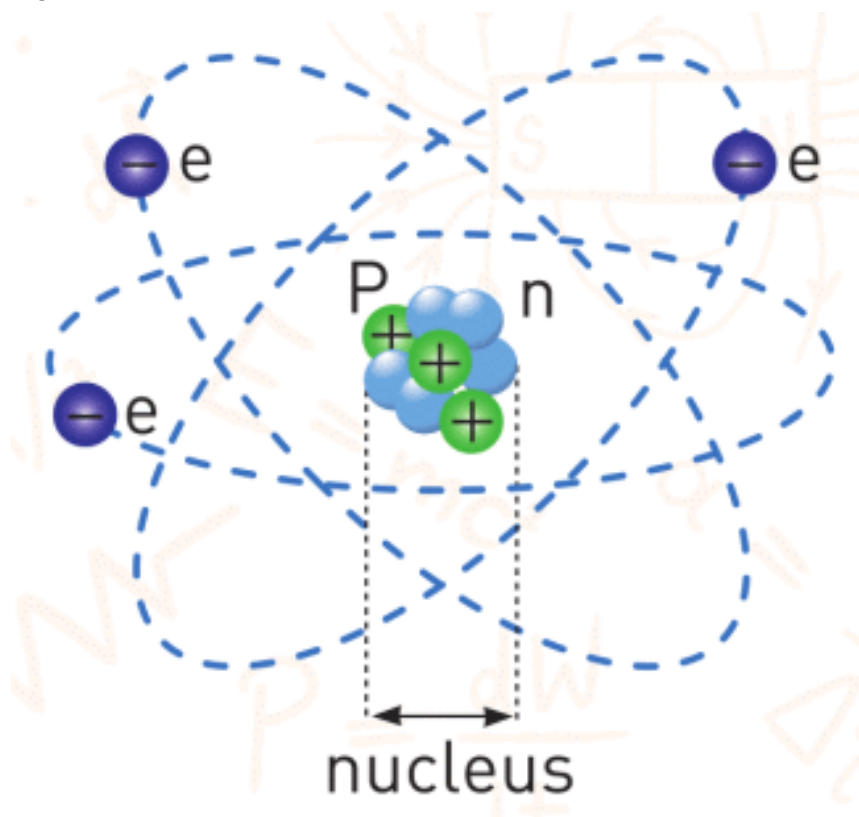

- Like (same) charges repel each other. Unlike (not same) charges attract each other. This force is called electrostatic force.

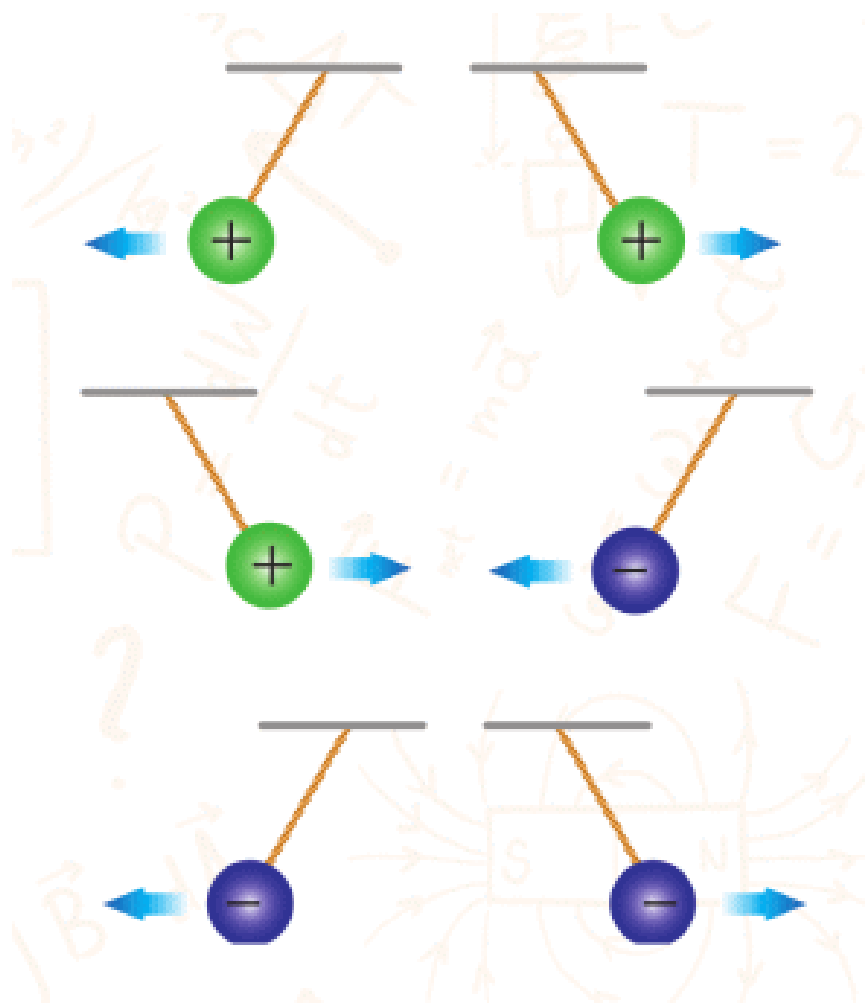

- Negatively charged object has more electrons than protons. Positively charged object has more protons than electrons.
- Law of conservation of charge states that charge can be transferred, but total charge is always constant.
- We can calculate force between charges using the Coulomb's law:
-

$$F = k \frac{q_1 \times q_2}{r^2}$$

- The smallest charge in nature is called elementary charge and it is charge of one electron. Proton has the same charge, but it is positive.
- $e = -1.6 \times 10^{-19} \text{ C}$
- Charges produce field around them. It is called electric field. Electric field produces force - electric force.
- $F = q \times E$

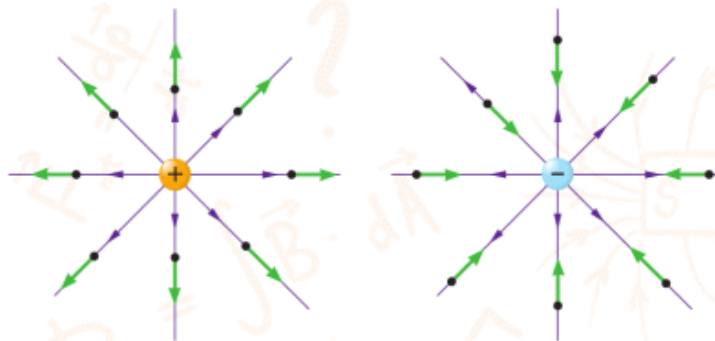

- Electric field stores energy. This energy depends on charges and distance between them. Energy per unit charge is called electric potential. Symbol ϕ is used to denote potential. Volt is the unit of potential.



- Capacitor is device that stores electric charge.
-

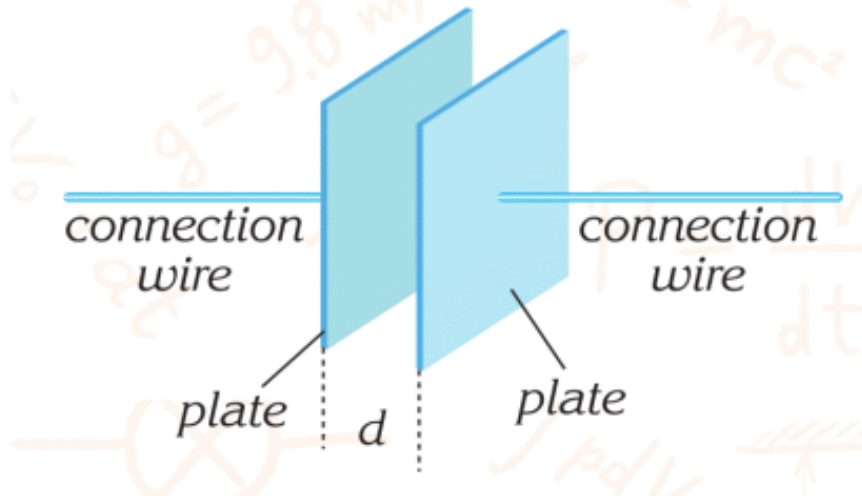

PROBLEMS

ELECTRIC CHARGE

1. When you rub a comb or a pen on a dry cloth, paper is attracted to the comb. Explain why.
2. Is it possible to produce a single type of charge in a rubbing process? Explain.
3. Does the mass of a positively charged metallic sphere change if you touch it? How about a negatively charged sphere?
4. What are the different types of charge? Where is the location of these charges in materials?
5. What is a neutral object? Explain.

INSULATORS AND CONDUCTORS

6. Why do we use silk threads to suspend charged rods instead of metallic threads?
7. You can never charge a plastic rod by contact or by induction. Why?

INDUCED CHARGE

8. A balloon is charged by rubbing and brought near a tiled wall. It is observed that when the balloon is released, it sticks to the wall. Why?

9. Three neutral, identical conducting spheres K, L and M are brought into contact and then a positively charged sphere, S, is brought nearby. Suppose K and M are separated from L by holding them by their insulating stands, and then sphere S is removed.

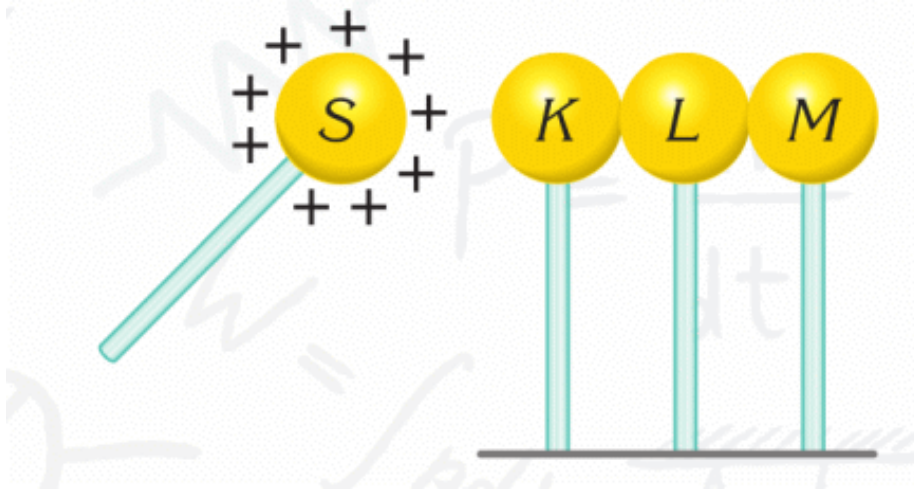

What is the final type and magnitude of charges on the spheres K, L and M?

10. A positively charged object A is brought near to a neutral sphere B, which is in contact with a grounded neutral sphere. What will the charges on objects A, B and C be if, after cutting the ground connection, the spheres are separated and object A removed.

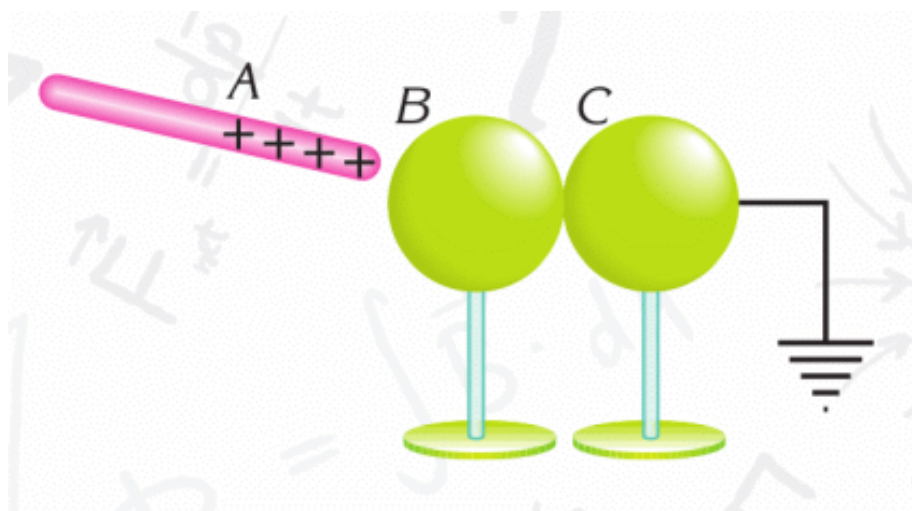

ELECTROSCOPE

11. When a charged rod is brought near to a negatively charged electroscope, the leaves of the electroscope collapse. What is the charge on the rod?

12. Positively charged object K is brought between the two neutral conducting materials, as shown in the figure. What is observed on the electrosopes in figures I and II?

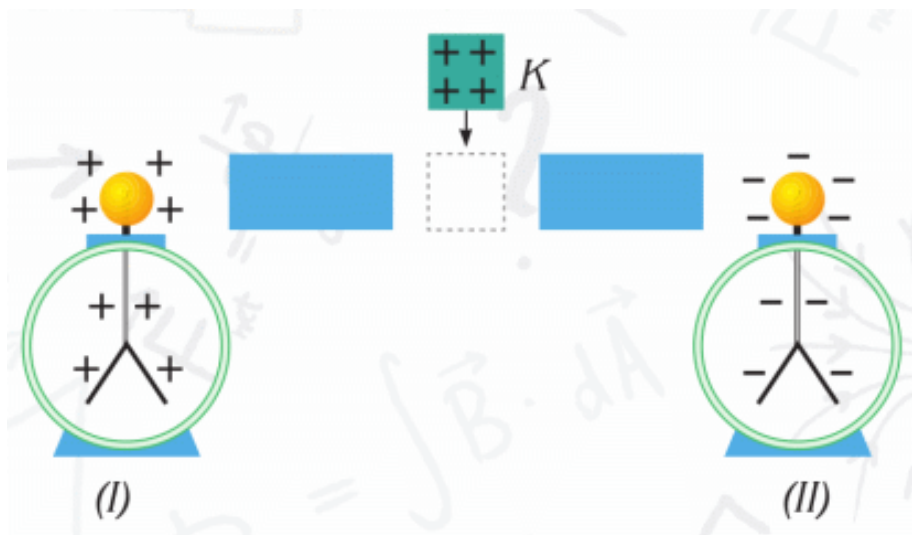

COULOMB'S LAW

13. Two identical spheres, with charges $q_1 = 4 \cdot 10^{-8}$ C and $q_2 = 2 \cdot 10^{-8}$ C, are separated by a distance of 0.1 m. Find the electrostatic force exerted by one charge on the other.

14. The electric force between the charges of $q_1 = 2.5 \mu\text{C}$ and $q_2 = -4 \mu\text{C}$ is $3.6 \cdot 10^{-4}$ N. What is the distance between them? ($1 \mu\text{C} = 10^{-6}$ C) 15. What is the electric force between two clouds, having charges $q_1 = 20$ C and $q_2 = 10$ C, if the average distance between them is 5 km.

16. How does electric force change when the distance between two point charges is increased three times?

ELECTRIC FIELD. ELECTRIC FIELD LINES

17. Find the magnitude of the electric field at a point 10 cm from a point charge of $q = -6 \mu\text{C}$.

18.

a) The electric field at a point 27 cm from a charged particle is 10^5 N/C toward the particle. What is the charge on the particle? Find force acting on $q = -1 \mu\text{C}$ at that point.

b) A point charge of $1 \mu\text{C}$ experiences an electric force of 0.02 N. What is the magnitude of electric field at that point?

ELECTRIC POTENTIAL

19. Find the electric potential of a charge $3 \cdot 10^{-7}$ C, at distances away from its position of 5 cm and 20 cm.

20. Find the electric potential at point P for the system of charges q_1 and q_2 , shown in the figure.

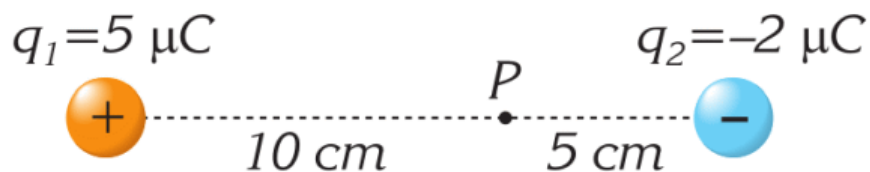

21. The work done by the electric force to move a charge $q = 3 \cdot 10^{-7} \text{ C}$ is 6000 J. What potential difference does the charge move through?

22. Two point charges of $1 \mu\text{C}$ each are located 50 cm apart. What work is done to bring the charges to a separation of 5 cm?

CAPACITANCE. CAPACITORS

23. What happens to the charge on a capacitor if the potential difference between its conductors is:

- a) Doubled.
- b) Tripled.
- c) Halved.

24. A 4 volt source is connected across a $2 \mu\text{F}$ capacitor. Find the charge on this capacitor.

PARALLEL PLATE CAPACITORS

25. Find the capacitance of a parallel-plate capacitor if the area of each plate is 200 cm^2 and the distance between them

is 2 mm.

26. The area of each plate of a parallel-plate capacitor is 500 cm^2 . What separation must the plates have in order for their capacitance to be 500 pF ?

27. A parallel-plate capacitor of plate area 200 cm^2 and separation 4 mm, is connected to a voltage source of 3 kV. What is the charge on each plate?

USE THE WORDS BELOW IN YOUR OWN SENTENCES

nucleus, electron, charge, neutral, conductor, plastic wrap, photocopying machine

FILL IN THE BLANKS WITH APPROPRIATE WORDS

1. All matter is made up of
2. Most atoms are electrically
3. Like charges each other. But unlike charges each other.
4. are materials which do not allow electrons to pass through.
5. An can detect whether an object has charge.

ANSWER THE QUESTIONS

1. What particles are contained in an atom? What are their charges and positions?

2. How can charges be built-up on an object? Explain three different methods.

3. How do the leaves of a neutral electroscope behave when a charged rod is brought close to the knob of the electroscope?

4. If two objects attract each other, must both of them be charged? Explain.

5. What is grounding? Explain, giving an example from everyday usage.

ANSWER THE TEST QUESTIONS

1. When an object is charged, which of the following changes?

A) the number of protons

B) the number of electrons

C) the number of neutrons

D) the number of protons and electrons

2. When you walk on a rug and then touch a conducting object, you often get an electric shock due to an electric discharge because:

A) Electricity is produced due to friction between the rug and your body.

B) Your body produces electricity.

C) The rug produces electricity.

D) The conducting object produces electricity.

3. If a charged sphere is brought close to a neutral metal sphere as shown in the figure above. Which of the sketches below indicates how charge distributes along the neutral sphere?

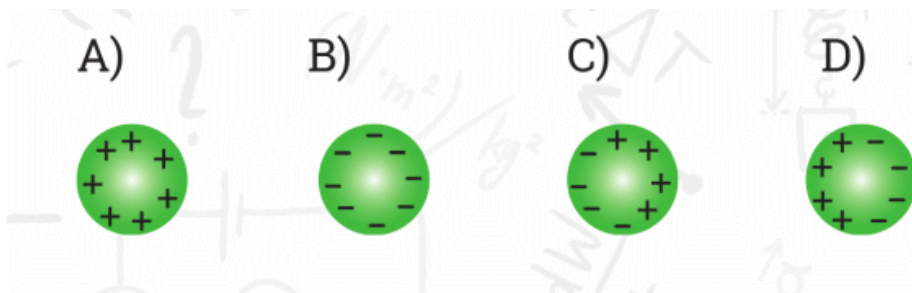
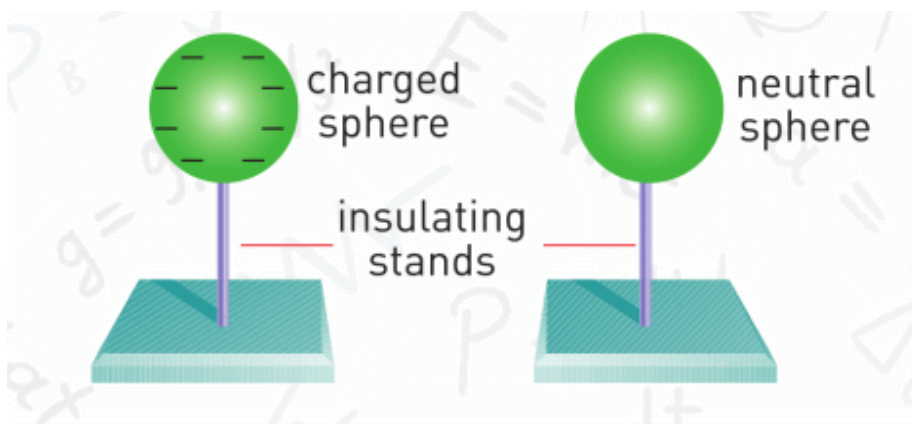

4. A positively charged conducting object becomes neutral when it is grounded. Which of the following explains this phenomenon?

- A) Extra protons on the object have moved to the ground.
- B) Electrons in the grounding wire have travelled up to the object.
- C) Positive charges have attracted electrons from the ground.
- D) Neutrons in the object have travelled to earth.

5. When rod (I) is brought close to the knob of a negatively charged electroscope, the leaves rise up, when rod (II) is brought close, the leaves drop down.

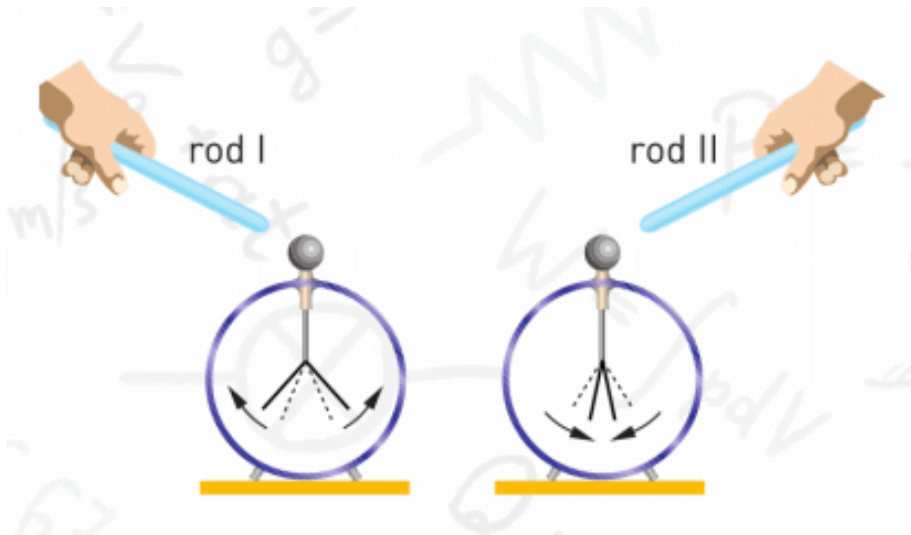

What can be said about the charges on the rods?

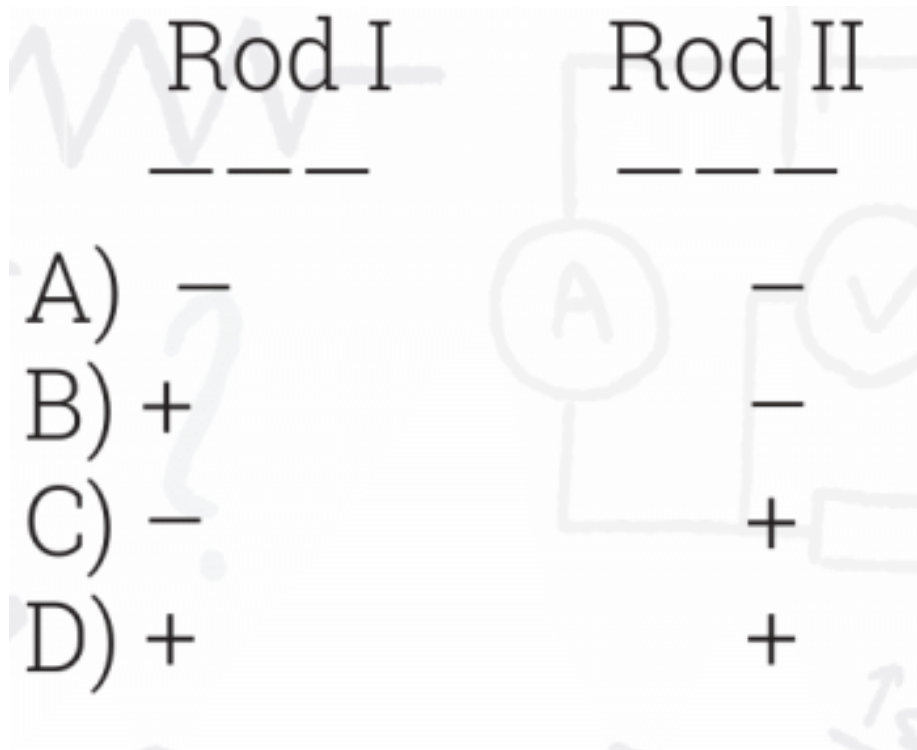

- A) -
- B) +
- C) -
- D) +

6. When a comb is rubbed through hair, it gains charge. What are the charges on the hair and the comb?

- A) hair (-), comb (-)
- B) hair (+), comb (+)
- C) hair (-), comb (+)
- D) hair (+), comb (-)

PHYSICS IN LIFE

1. Flower pollen sticks to bee's body. Why?



2. Plastic wrap does not have glue on it, but it can stick. Why?



3. This man uses electricity in car painting. Why?



4. We generally see lightning during the rain. Why?



5. Toner in printers "knows" where to stick on the paper.
How?



6. Electrophoresis can "push" medical drug into human body? How?



7. Some engineers wear ground bracelet. Why?



CHAPTER 5

ELECTRIC CURRENT

5.1 ELECTRIC CURRENT

5.2 ELECTRIC CIRCUIT. VOLTAGE

5.3 ELECTRICAL RESISTANCE

5.4 RESISTIVITY

5.5 PARALLEL AND SERIES CONNECTIONS OF RESISTORS

5.6 ELECTRICAL ENERGY AND POWER

5.7 SHORT CIRCUIT

5.8 ELECTRIC CURRENT IN LIQUIDS AND GASES

LAB WORK 3

LAB WORK 4

LAB WORK 5

LAB WORK 6

LAB WORK 7

SUMMARY

PROBLEMS

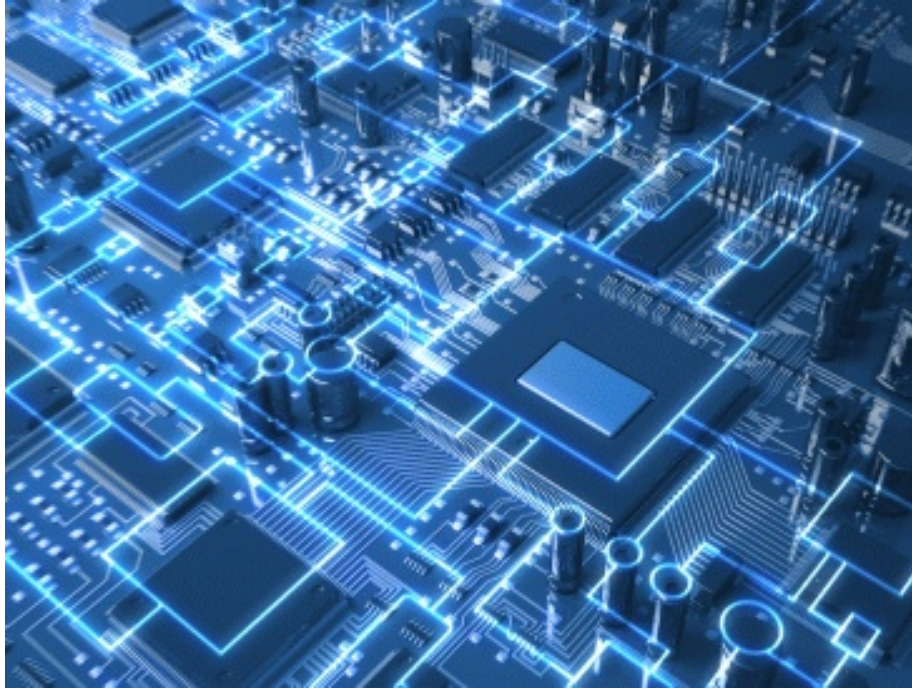

5.1 ELECTRIC CURRENT

YOU WILL:

- - explain conditions for production of electric current.

QUESTION

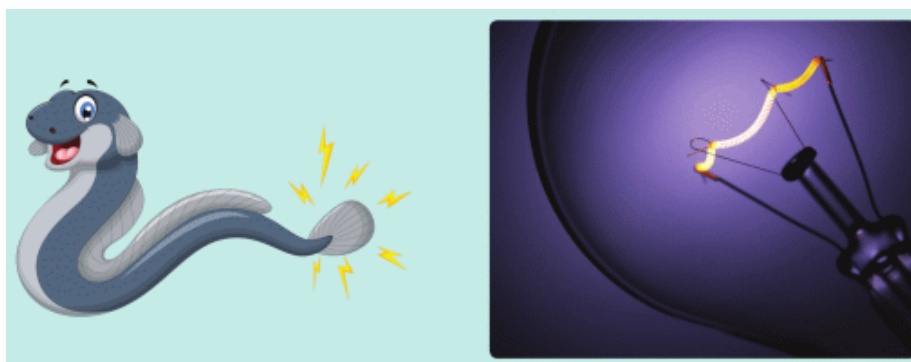

What is the similarity between an electric eel and a bulb?

ELECTRIC CURRENT

The potential difference (voltage) of battery “pushes” electrons through wires. The directed motion of charged particles in a circuit is called electric current, Figure 1.

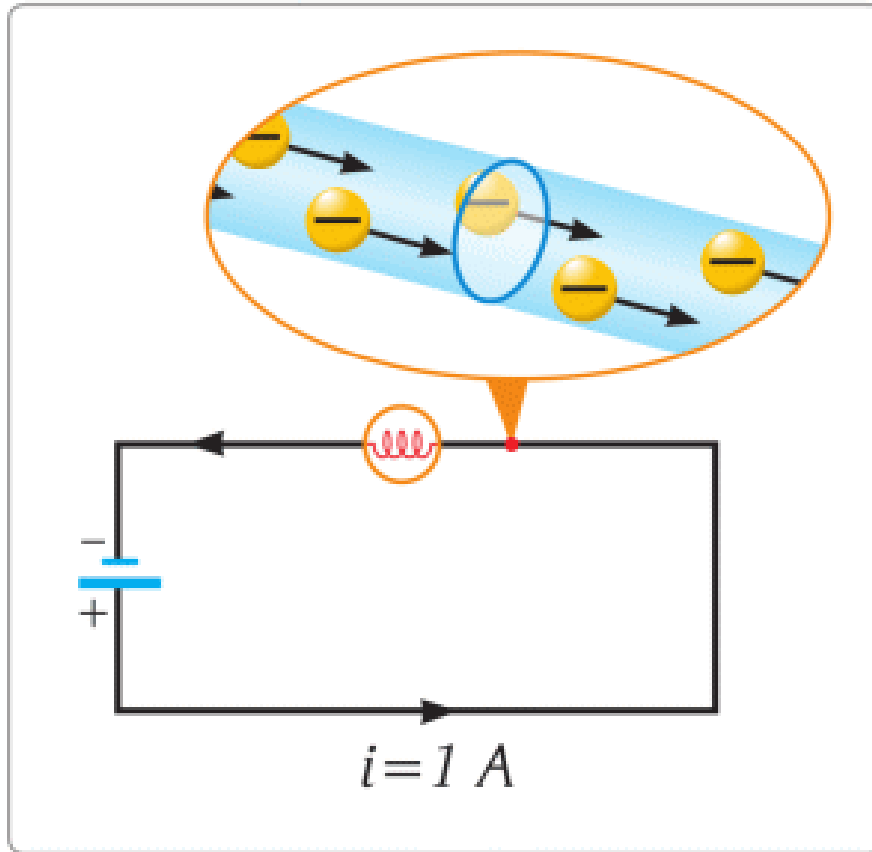

Figure 1

Electric current is similar to the water flow in pipes, Figure 2.

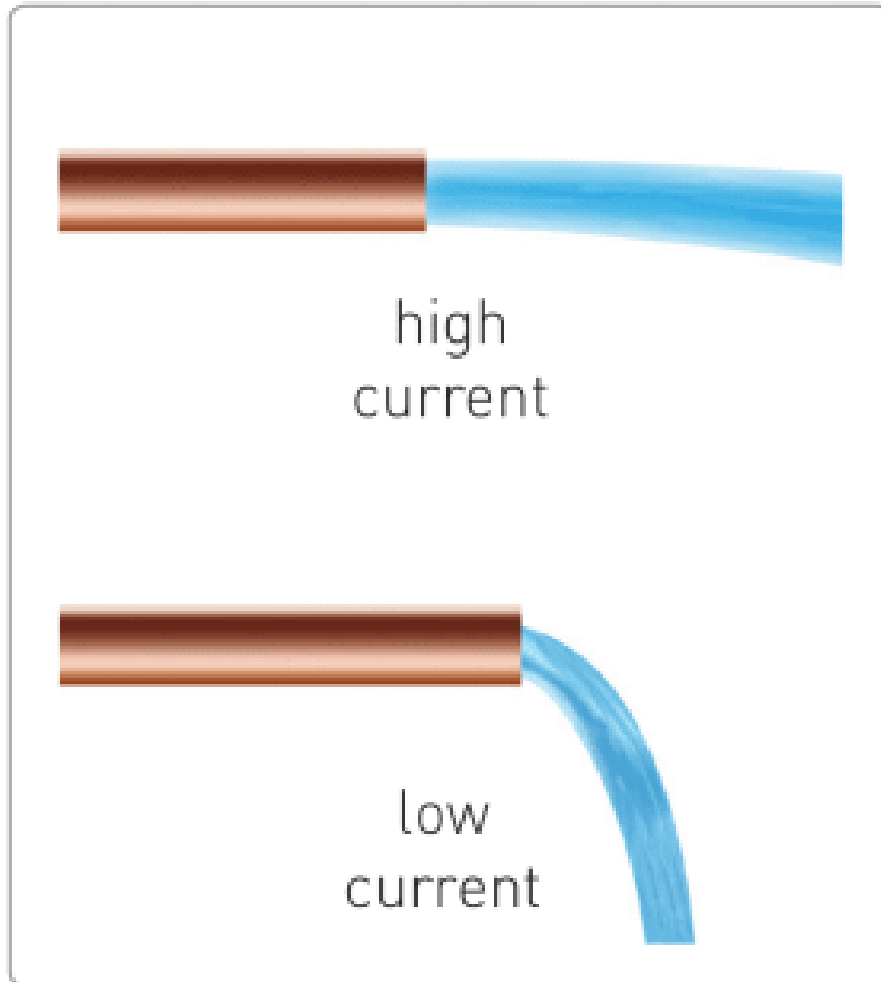

Figure 2

The formula of electric current is:

$$I = q / t$$

I	=	q	/	t
Current (Ampere)		Charge (Coulomb)		time (second)

1 Ampere of electric current is equal to 1 Coulomb of charge passing in 1 second. That is why 1 Ampere of current equals

to $6.25 \cdot 10^{18}$ electrons passing in one second.

SOURCE OF ELECTRIC CURRENT

Электр тогының көздері Тұрақты электр тогы пайда болуы үшін ең алдымен батареялар қажет, Figure 3. Электр құралдарының көпшілігі батареямен жұмыс істейді.



Figure 3

CONDUCTORS AND INSULATORS

Өткізгіштер және диэлектриктер Кейбір материалдар электр тогын жақсы өткізеді. Бұл материалдар өткізгіштер деп аталады. Ал, кейбір материалдар керісінше, электр тогын өткізбейді. Олар диэлектриктер немесе изоляторлар деп аталады.

Материалдардың тағы бір бөлігі электр тогын белгілі шарттарда ғана өткізеді. Бұлар жартылай өткізгіштер деп аталады. Table 5.1-де мысалдар көрсетілген.

Good conductor	Poor conductor	Insulator
copper	human body	rubber
silver	earth	plastics
gold	salty water	glass
mercury	germanium	dry air

Table 5.1

FACT



High voltage electricity wires have no insulating materials on them. However, birds can safely sit on only one of them. If it touches two wires at the same time, current will hurt the bird.

EXAMPLE

What charge does pass through 0.5 Ampere lamp in 200 seconds?

Solution:

$$I = \frac{q}{t}$$

$$q = 0.5 \times 200 = 100 \text{ C}$$

ACTIVITY

Conductor and Insulator

Look at the pictures. Find conductors and insulators on them.





Why some objects are conductors and other are insulators?
What may happen if you replace them?

ACTIVITY

Батареялардың электр сыйымдылығын сипаттау үшін [мАсағ] қолданамыз.

$$1 \text{ мАсағ} = 1 \times 10^{-3} \text{ А} \times 3600 \text{ с} = 3.6 \text{ Кл}$$

Бұл формула арқылы батареяны зарядтауға кететін уақытты есептей аламыз. Ол үшін батареяның электр сыйымдылығын (мАсағ) және зарядтаушының ток күшін (А) білу керек.

Берілген кестені қолдана отырып, құрылғыларды зарядтау үшін қажет уақытты анықтаңыздар.

Device	Battery	Charger
Huawei Honor 6	3100 mAh	2 A
Acer E 15	4400 mAh	4.74 A
Mi power bank	10400 mAh	2 A
Mi band 2	70 mAh	1 A

RESEARCH TIME

a) Main materials: battery, wires, crocodile clips.

Extra materials: eraser, paper, spoon, key, etc.

Procedure: Set up the construction. Do the same with each material and fill the table.

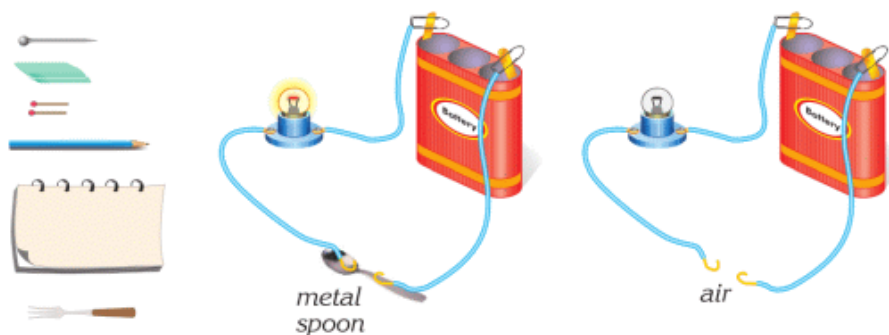

Material	Conductor	Insulator
Eraser	x	✓
Needle		
Paper		
...		

b) Why do some materials conduct current, and others do not? Can you find the information about that?

ART TIME

Make a “fruit battery” or “vegetable battery”. Show it to your parents, teachers, and friends.

LITERACY

1. A human body has cells that produce electric current. Why do we need this current? What if we do not have these cells? Can you name these cells?
2. Why do people use electric batteries? What types of electric batteries do you use in everyday life? How do electric batteries work?
3. AAA type battery can store 1 Ah (Ampere × hour) charge. How many Coulombs is it equal to?

TERMINOLOGY

- electric current – электр тогы / электрический ток

- source of electricity – ток кәзі / источник тока
- conductor – өткізгіш / проводник
- insulator – изолятор / изолятор

5.2 ELECTRIC CIRCUIT. VOLTAGE

YOU WILL:

- - use schematical drawings of elements to draw electric circuit;
- - explain physical meaning of voltage and its unit of measurement.

QUESTION



Where would you use these batteries? Why?

ELECTRIC ELEMENTS

Төмендегі суретте қарапайым электр элемент кескіндері мен белгілері көрсетілген. Бұл белгілерді электр элементтерін сыздада көрсету (сұлба) үшін қолданамыз. Себебі оларды салу жеңіл әрі қолайлы, Figure 1.

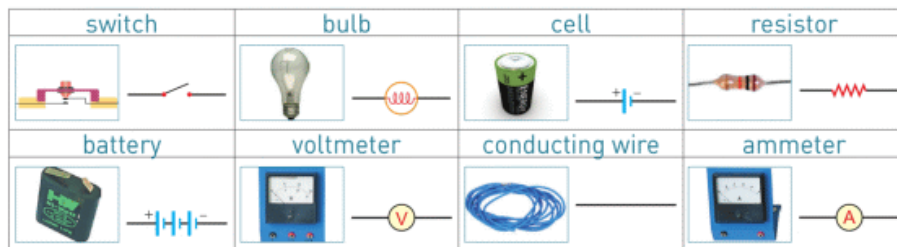

Figure 1

ELECTRIC CIRCUIT

Электр құралдарын жалғау арқылы электр құрылғыларын жасай аламыз. Мысалы, қарапайым қалташам жасау үшін батарея, шам, кілт және сымдар қажет. Бұларды бір-біріне жалғаған кезде электр тізбегі пайда болады.

Бұл электр тізбегін сұлба арқылы да көрсетуге болады Figure 2.



Figure 2

Электр құрылғылардың барлығы (смартфон, компьютер, зарядтағыш т.с.с) электр тізбегінен құралады. Әр электр құрылғының сұлбасы өзімен бірге беріледі, Figure 3.

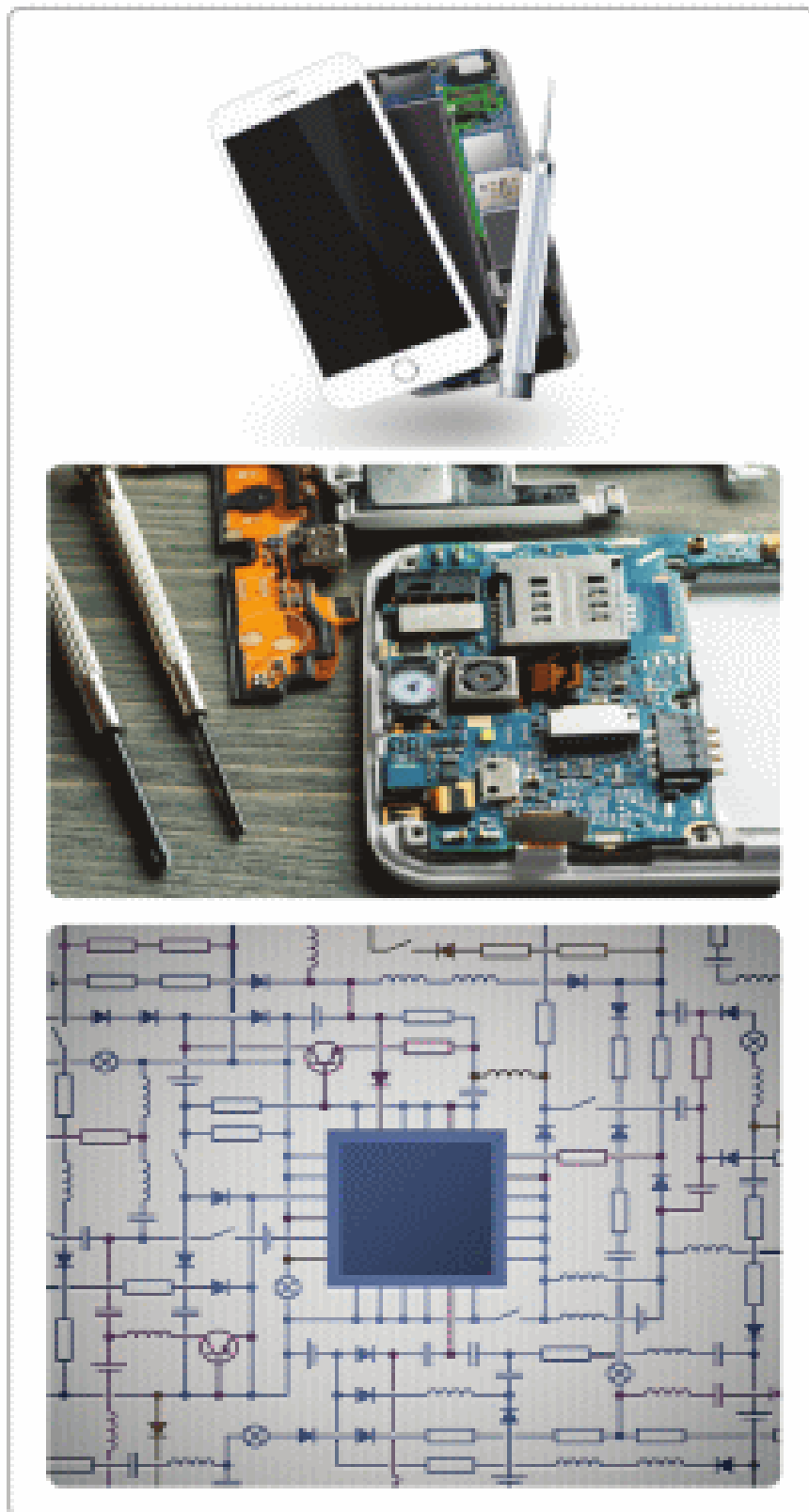

Figure 3

VOLTAGE

Электр құрылғылардың жұмысы үшін ток күші қажет. Ток күшінің пайда болуына кернеу себеп болады. Төмендегі Figure 4-ке назар аударыңыз.



1.5 Volts and 9 Volts



3.6 Volts

Figure 4



220 Volts

Батареялар мен розетканың айырмашылығы олардың кернеулерінде. Кернеу электронды қозғайтын "электр энергиясы" тәріздес. Сондықтан, кернеудің шамасы мен электр тогы бір-біріне тура пропорционал. Яғни кернеу қаншалықты үлкен болса, электр тогының шамасы да соншалықты үлкен болады.

FACT

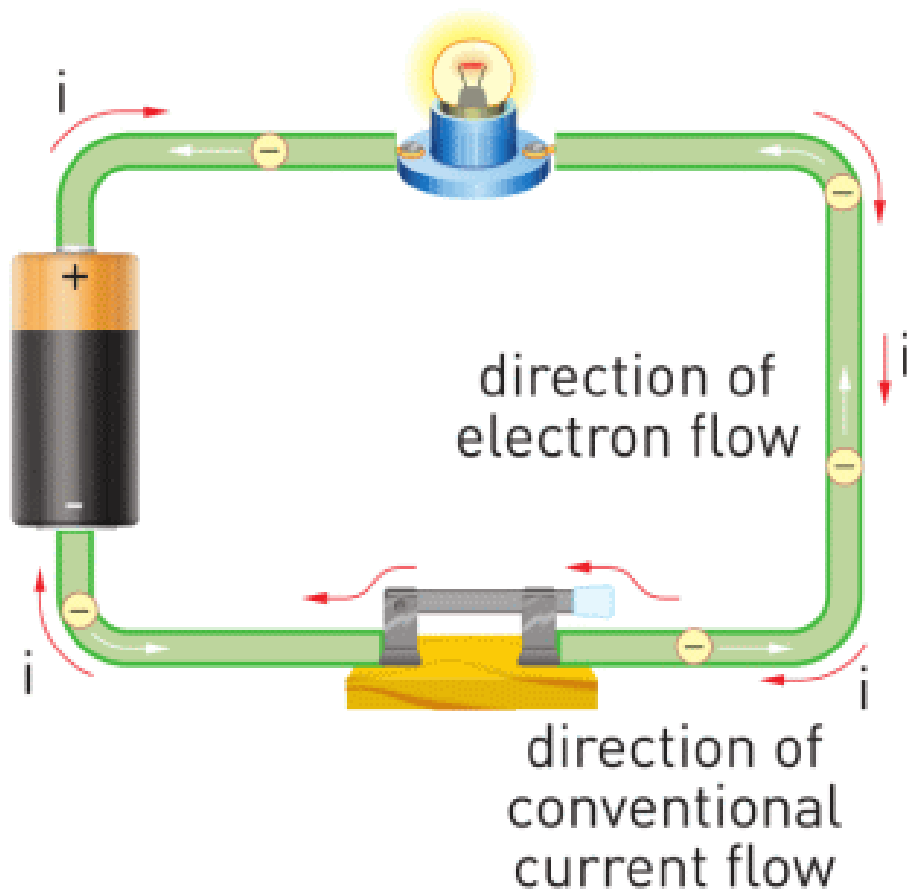

Electron flow is in the opposite direction to the flow of current.

ACTIVITY

This is a plan of a house.

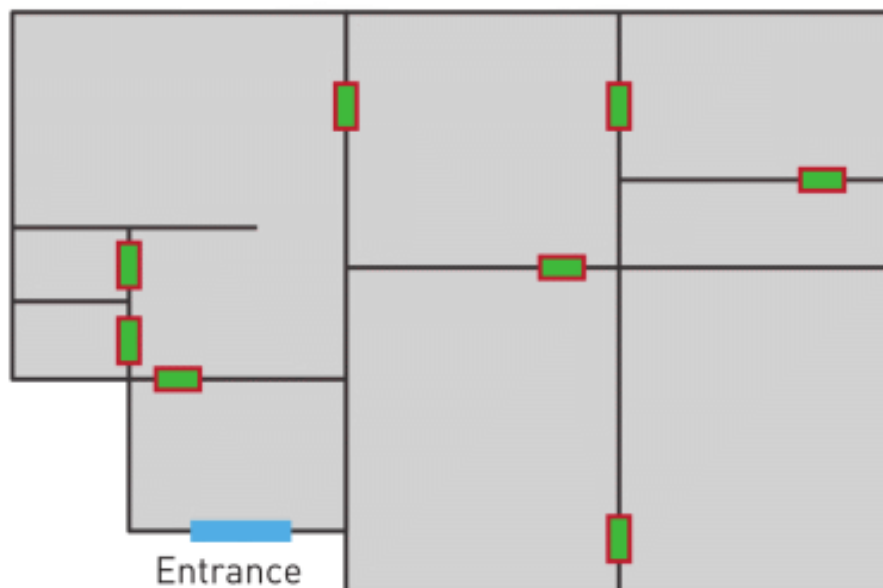

You have an unlimited number of bulbs and wires, but only 1 switch and 1 battery.

- Draw a schematic diagram of a simple electric circuit that gives light to each room. How many lamps do you use here?
- Draw a plan of your house with a simple circuit.

FACT

Store your batteries in a cool, dry place. If you put them in a refrigerator, they will last longer.

RESEARCH TIME

Do research about other circuit elements.

EXAMPLE

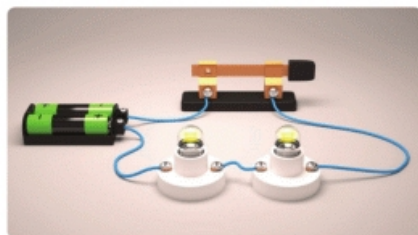

Closed circuit

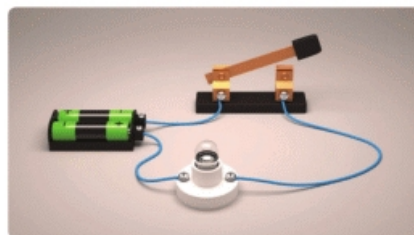

Open circuit (no current)

Draw an electric circuit diagram of these pictures.

Solution: We can draw circuits as in the images below. There is electric current in the closed circuit, and there is no current in open circuit.

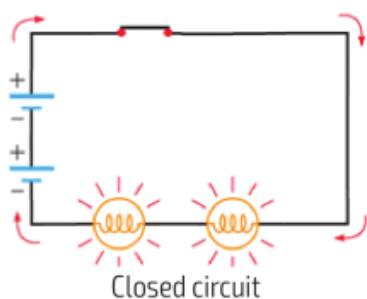

Closed circuit

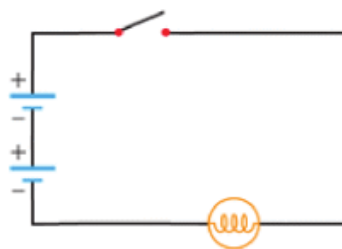

Open circuit (no current)

LITERACY

1. Why do electric socket (220 Volts), laptop (19 Volts), car battery (12 Volts) and mobile phone (3.6 Volts) use different voltage?
2. What may happen if we connect a light bulb that normally works on 20 V to 220 V?
3. What may happen if we connect a light bulb that normally works on 220 V to 20 V?
4. Why we do not use 10000 Volts in our homes?
5. Draw a circuit diagram for this image.

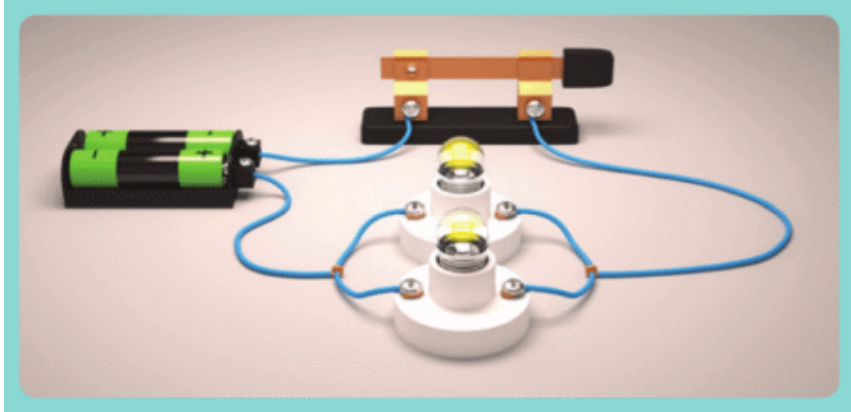

6. Draw a circuit diagram which has these: 5 batteries, 7 bulbs, 3 switches.

ART TIME

Draw a picture that shows voltage. Show the drawing to your parents, teachers and friends.

TERMINOLOGY

- electric circuit - электр тізбегі / электрическая цепь
- circuit diagram - тізбектің сұлбасы / схема цепи
- voltage - кернеу / напряжение

5.3 ELECTRICAL RESISTANCE

YOU WILL:

- apply Ohm's law for part of electric circuit for problem solving.

QUESTION

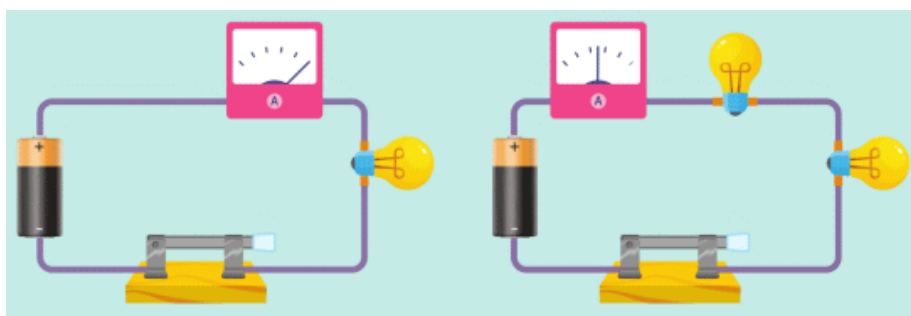

Why does ammeter show current two times smaller in the second case?

ELECTRICAL RESISTANCE

Әр өткізгіштің атомдар арақашықтары және еркін электрондар саны әр түрлі болып келеді. Сондықтан еркін электрондардың саны өткізгіштің түріне байланысты өзгереді. Осы еркін электрондар қозғалған кезде өткізгіштің атомдарымен соқтығысып, қозғалыстары қиындай түседі. Басқаша айтқанда, өткізгіштің өзіндік құрылымы электрондардың қозғалысына кедергі болады. Бұл құбылыс электр кедергісі деп аталады Figure 1.

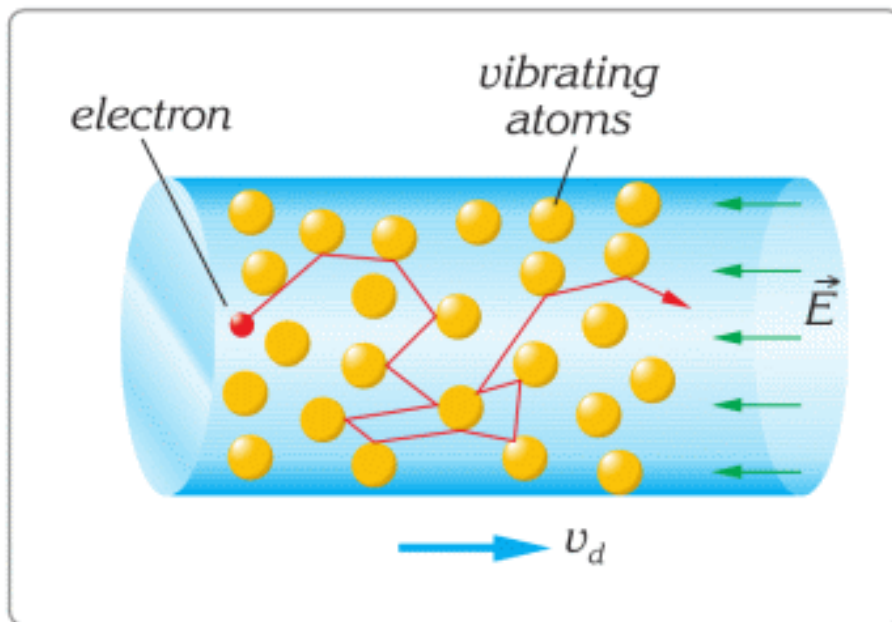

Figure 1

Өткізгіш арқылы өтетін зарядтар мөлшері кернеуге тәуелді. Кернеу неғұрлым көп болса соғұрлым заряд көп өтеді. Ток күші, кернеу және кедергі арасындағы қатынас Ом заңы деп аталады:

$$I = U / R$$

I	=	U	/	R
Current (A, Amper)		Voltage (V, Volt)		Resistance (Ω, Ohm)

Бұл формула бізге үлкен ток күшін алудың екі жолы бар екендігін көрсетеді. Біріншісі, кернеуді көбейту арқылы. Екіншісі, кедергіні азайту арқылы.

Кез келген сым, шам, мотор, батарея, және т. б. заттарда электр кедергісі болады. Кедергісі бар заттарды цилиндр

ретінде қабылдай аламыз, Figure 2.

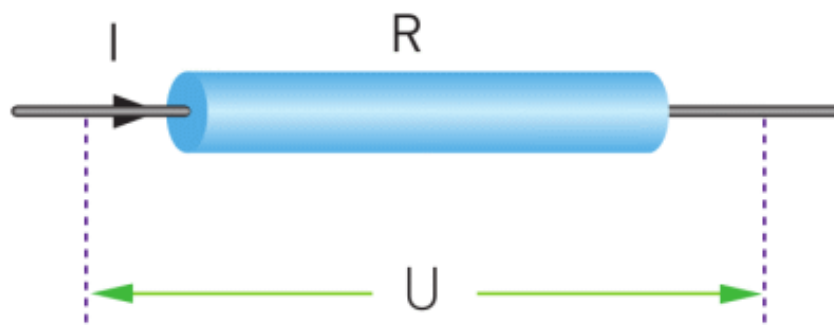

Figure 2

EXAMPLE

A student connected a light bulb to a battery. The current through bulb is 0.1 A. The voltage is 1.5 V. What is the resistance of the bulb?

Solution:

$$R = \frac{U}{I};$$

$$R = \frac{1.5}{0.1} = 15 \Omega;$$

ACTIVITY

Colour codes of resistors.

Read the information below.

Then, do the ACTIVITY.

Every electronic device has resistors inside, Figure 3. We use resistors to control the amount of current passing through elements.

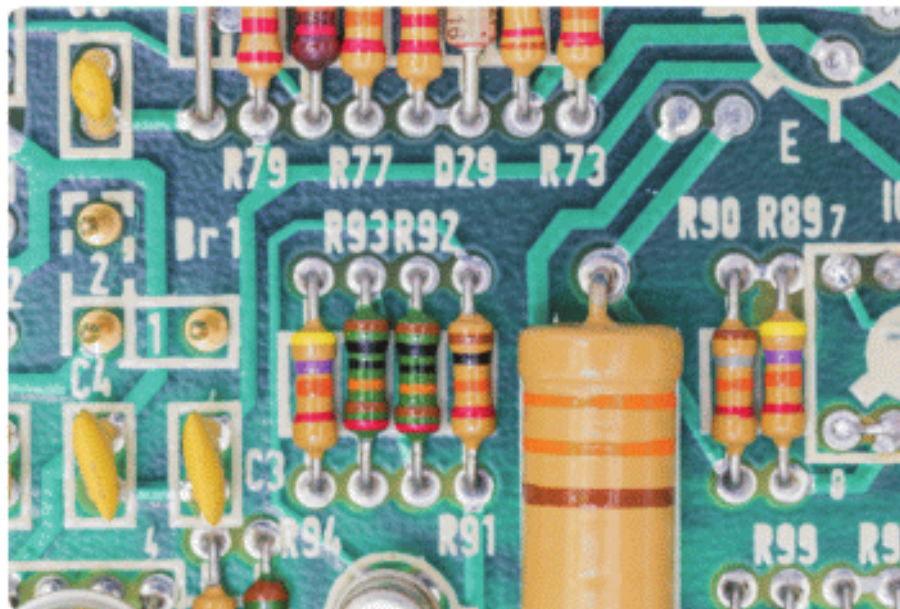

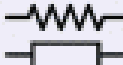

Figure 3

These resistors can be very small in length (3-4 mm). However, their resistance sometimes can be up to 500000 Ω . Such long number will not fit on 3-4 mm resistor body. That is why people draw rings of different colour of resistors. We use the table of colour codes to read the value of resistance.

5 Bands  68 K Ω 5%

Color	1st Digit	2nd Digit	3rd Digit	Multiplier	Tolerance
Black	0	0	0	1	
Brown	1	1	1	10	1%
Red	2	2	2	100	2%
Orange	3	3	3	1 K	
Yellow	4	4	4	10 K	
Green	5	5	5	100 K	0.5%
Blue	6	6	6	1 M	0.25%
Violet	7	7	7	10 M	0.1%
Gray	8	8	8		0.05%
White	9	9	9		
Gold				0.1	5%
Silver				0.01	10%

 **Resistor Color Codes** 1K = 1 000
1M = 1 000 000

1. Silver or gold colours represent the tolerance. It is the possible percentage error.
2. The ring before silver or gold ring is a multiplier (number of zeros).
3. Other rings mean digits before a multiplier.

Let us use the table in the example below.

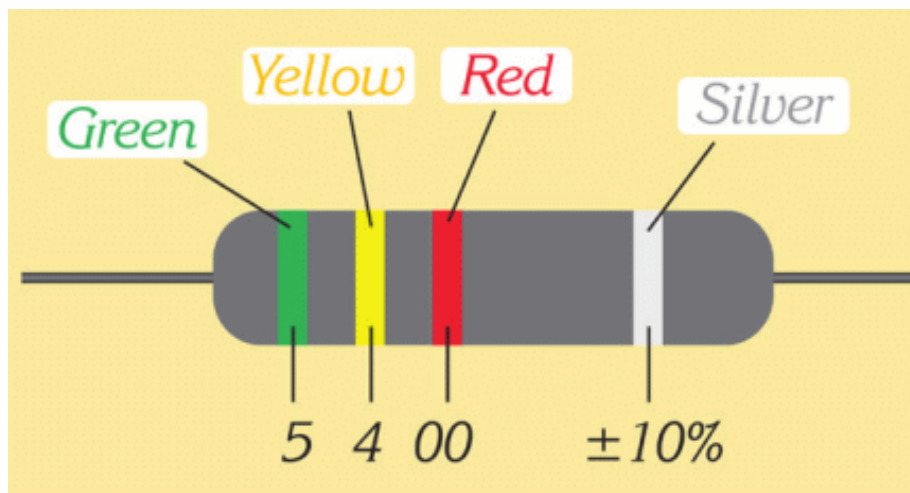

1. The tolerance is 10%.
2. Ring before tolerance is red: 2 zeros.
3. Yellow ring: 4.
4. Green ring: 5.

Then, the resistance is $5400 \pm 10\% \Omega$. This means that the minimum value is $5400 - 540 = 4860 \Omega$. The maximal value is $5400 + 540 = 5940 \Omega$.

ACTIVITY

a) Draw a picture of the following resistance by using colour code.

- $150\ 000 \Omega$
- $235\ 600 \Omega$
- 10Ω
- $76\ 300 \Omega$

b) Draw pictures of any resistors by using a colour code. Let your classmates define the values of your resistance.

FACT

A tool for measuring voltage in an electric circuit is called a voltmeter. An ohmmeter is used for measuring resistance.

A multimeter can measure several parameters. For example, voltage, current, resistance and temperature.

LITERACY

1. Electric kettle uses 220 Volts and 10 Amperes. How many Ohms is the resistance of the kettle?
2. Current of more than 0.01 Amperes is dangerous for people. Resistance of human body is about 2000 Ohms. How many Amperes do 220 Volts produce? Is this current dangerous?
3. Electric eel can produce about 800 Volts. Wet human body is about 500 Ohms. How many Amperes do pass through the body if an electric eel attacks?

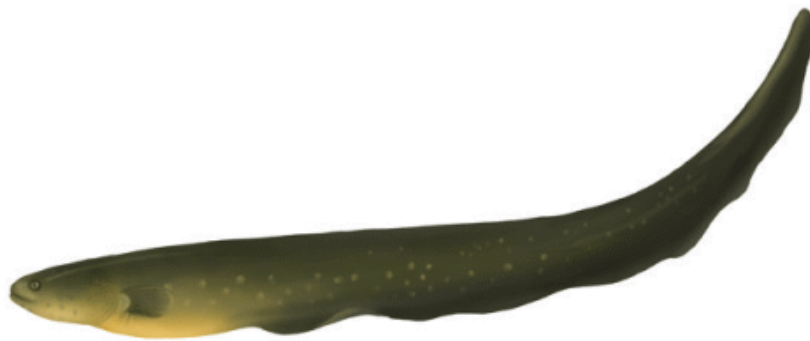

4. Why does every circuit element have electrical resistance?
5. When the temperature of a conductor is low enough, the conductor can become a superconductor. In this state the electrical resistance tends to be zero. What is possible useful application of superconductors?

ART TIME

Show current, resistance, and voltage in a dance. Show the dance to your parents, teachers, and friends.

TERMINOLOGY

to resist - кедергі жасау / сопротивляться

resistance - кедергі / сопротивление

tool - құрал-жабдық / инструмент

5.4 RESISTIVITY

YOU WILL:

- - explain physical meaning of electric resistance and its unit of measurement;
- - apply formula of resistivity for problem solving.

QUESTION

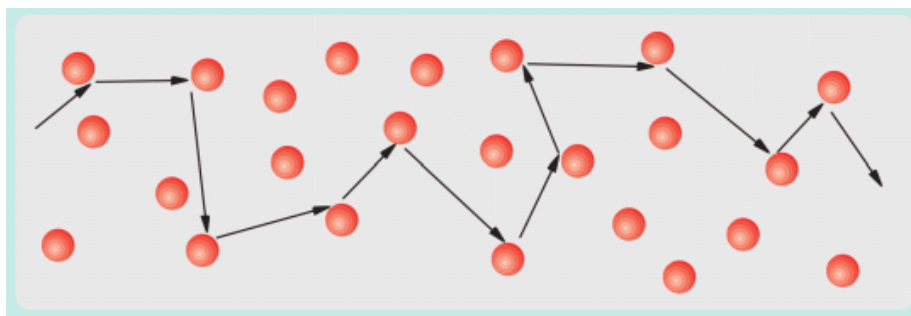

Is it difficult for an electron to go through a short wire or long wire? Why?

RESISTIVITY

A resistance of a conductor depends on three factors: length, cross-sectional area (thickness) and type of material.

LENGTH

Electrons inside the wire move because battery “pushes” them. When electrons move, they hit atoms of the wire. If a wire is long, then there are more atoms on the way. That’s why resistance of a long wire is high Figure 1.

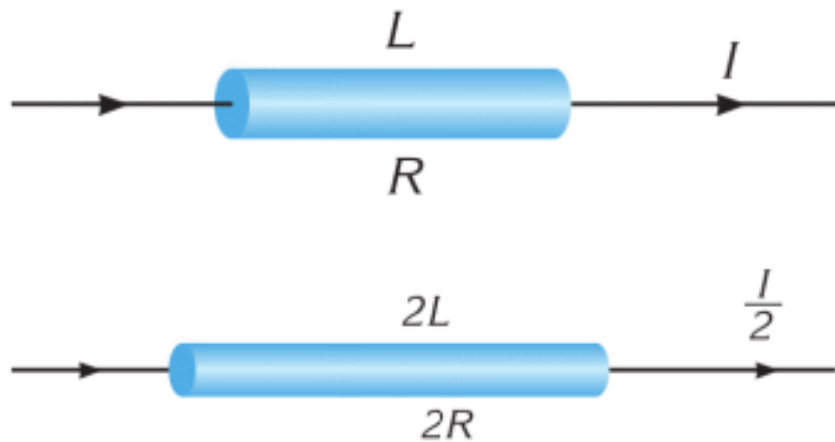

Figure 1

AREA

Thick wires (large area) have low resistance. This is because they have more space for electrons to move.

Thin wires have high resistance. They provide less space for the electrons to move. Look at Figure 2.

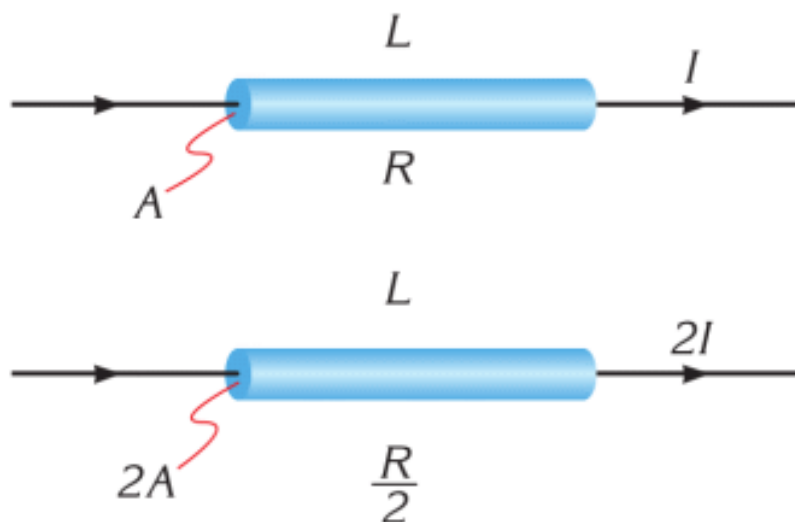

Figure 2

RESISTIVITY

In some materials, atoms make it easy for electrons to move. In other materials, atoms make it hard for electrons to move. In some materials (conductors) there are electrons that can move. In other materials (insulators) there are much fewer electrons that can move. That's why resistance depends on the type of material. Resistivity (Table 5.4) shows how hard it is for electrons to move through materials.

Material	Resistivity $\rho(\Omega \times \text{m})$
Silver	1.59×10^{-8}
Copper	1.7×10^{-8}
Gold	2.44×10^{-8}
Aluminium	2.82×10^{-8}
Tungsten	5.6×10^{-8}
Iron	10×10^{-8}
Nichrome	150×10^{-8}
Carbon	3.5×10^{-5}
Glass	10^{8-14}

Table 5.4

You can find resistance by this formula:

$$R = \rho \times \frac{l}{S}$$

R - resistance (Ω)

ρ - resistivity (type of material) ($\Omega \times m$)

l - length (m)

S - Area of conductor (m^2)

RESISTANCE AND TEMPERATURE

Балауыз майшам металл сымды қыздыра бастайды. Уақыт өткен сайын электр шам жарығы әлсірей бастайды. Демек, металл сымның кедергісі артты. Бұл мысалда сымның ұзындығы мен көлденең қимасы өзгертілген жоқ. Яғни, сымның меншікті кедергісі температураның артуына байланысты өскен болуы керек.

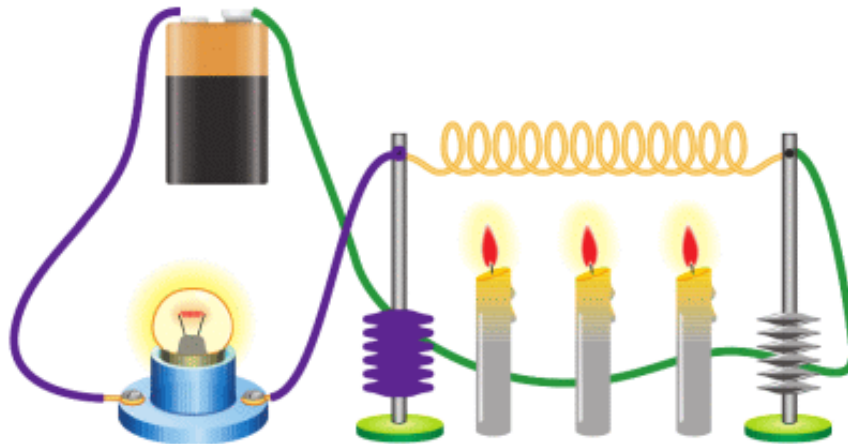

Сымдағы температура артқанда, оның бөлшектерінің қарқынды тербелісі де артады. Сымның кедергісі артады да, бойынан өткен электрондардың қозғалуы одан ары қиындайды.

Өткізгіш кедергісінің температураға тәуелділігін көрсететін график Figure 3 а -да көрсетілген.

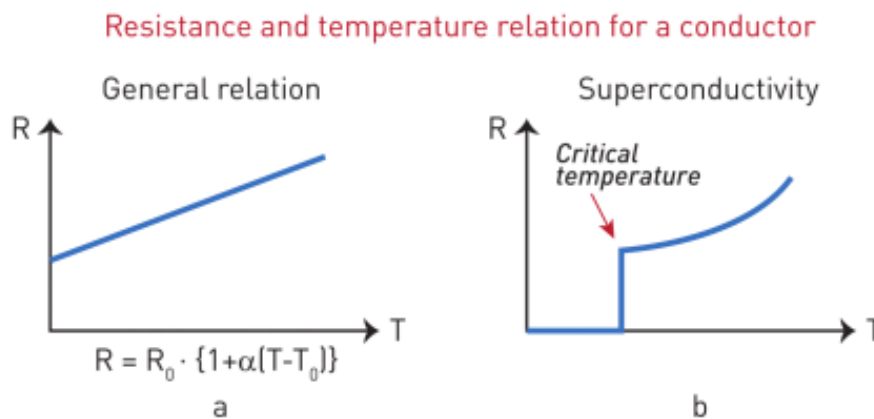

Figure 3

Эксперимент арқылы алынған график математикалық болжауды жақсы түсіндіреді. Бұл жерде α кедергінің температуралық коэффициенті, T және T_0 соңғы және

бастапқы температуралар, R және R_0 соңғы және бастапқы температурадағы өткізгіштің кедергілері.

Таза өткізгіштің кедергісі, өзіне тән сындық температураға жеткен кезде, кенеттен нөлге дейін түсіп кетеді. Бұл көбінесе өте төмен температураларда байқалады. Мысалы, сынаптың -270°C -та кедергісі нөлге тең болады. Бұл феномен асқын өткізгіштік деп аталады.

Қолданыста асқын өткізгіштердің болашағы зор. Өкінішке орай қазіргі таңда бөлме температурасында асқын өткізгіш болатын ешбір затты кездестірмейміз. Қазіргі таңда қол жеткізген асқын өткізгіштердің арасынан ең жоғары температура әлі де -70°C .

EXAMPLE

A copper wire has a cross-section area of 10 mm^2 and length of 200 m . What is the resistance of the wire?

Solution:

$$R = \rho \times \frac{l}{S}; \quad R = (1.7 \times 10^{-8}) \frac{200}{10^{-5}} = 0.34 \Omega$$

FACT



MagLev train

Superconductors are materials that have almost zero resistivity at very low temperatures (about -200°C). Superconductors are used in MagLev (magnetic levitation) trains. These trains do not touch the ground when they move.

RESEARCH TIME

Materials: A battery, a lamp, connecting wires, un-insulated wire (1 meter).

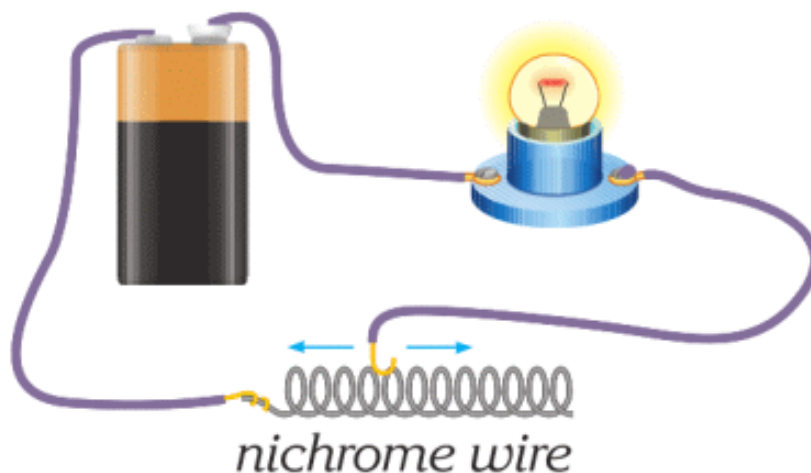

Procedure: What happens when you move one of the wires left or right?

ACTIVITY

a) How would you relate resistivity to speakers?

How would you draw a simple circuit diagram of speakers?

b) Speakers have a device that changes the volume.



Choose a problem that you face in daily life. Then design a solution to this problem by using the device.

LITERACY

- USB charging cable (1 m long) uses 5 Volts and 2 Amperes. a) How many Ohms is the USB charging cable? b) Copper is used for making cables. What is the area of the cable? Is it thin or thick?
- You make USB cables from iron. Cables have the same area and resistance as copper cables. What is the length

of iron cables? Are they shorter or longer than copper cables? Why?

- Generally, conductors in electrical devices are made up of copper or aluminium. Why do people prefer these metals?

ART TIME

Write a song about "resistivity". Sing it to your parents, teachers, and friends.

TERMINOLOGY

- resistivity – меншікті кедергі / удельное сопротивление
- cross-sectional area – көлденең қиманың ауданы / площадь поперечного сечения
- levitation – левитация / левитация

5.5 PARALLEL AND SERIES CONNECTIONS OF RESISTORS

YOU WILL:

- - design complex electric circuits (that have series and a parallel combination of resistors) by using Ohm's law.

QUESTION



If one bulb burns out in electric garlands, all other bulbs stop working. However, in cars and our homes, if one bulb burns out others keep working. Why?

SERIES COMBINATION

Тізбектей жалғау дегеніміз - резисторлардың біріншісінің соңына екіншісінің басының жалғануы.

Тізбектей жалғаудың ерекшеліктері:

1. Барлық резистор арқылы өтетін ток күші бірдей болады:

$I = I_1 = I_2$, Figure 1.



Figure 1. Series combination of resistors

2. Толық тізбек ұштарындағы кернеу тізбектегі әрбір резистор ұштарындағы кернеулердің қосындысына тең

$U_{total} = U_1 + U_2$, Figure 2.



Figure 2

3. Тізбектей жалғанған резисторлардың толық кедергісі барлық кедергілердің қосындысына тең:

$R_{eq} = R_1 + R_2$, Figure 3.

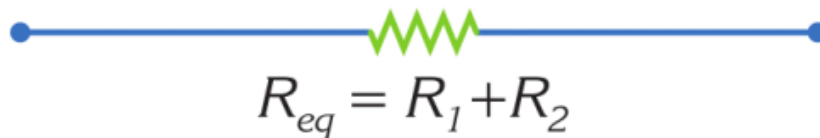

Figure 3

PARALLEL COMBINATION

Параллель жалғау деп екі резистордың бастарын бір нүктеге және соңдарын басқа нүктеге жалғануын айтамыз. Параллель жалғауда тізбектегі толық ток күші әрбір резисторға бөлінеді, Figure 4.

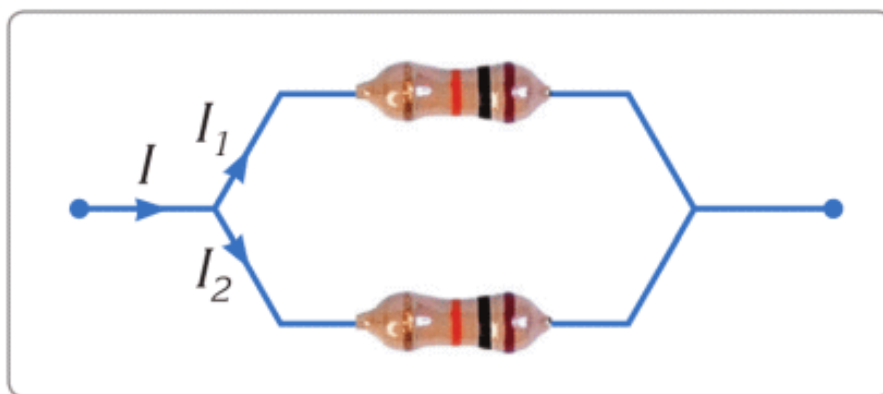

Figure 4

Параллель жалғаудың ерекшеліктері:

1. Әрбір резистор ұшындағы кернеу бірдей:

$U = U_1 = U_2$, Figure 5.

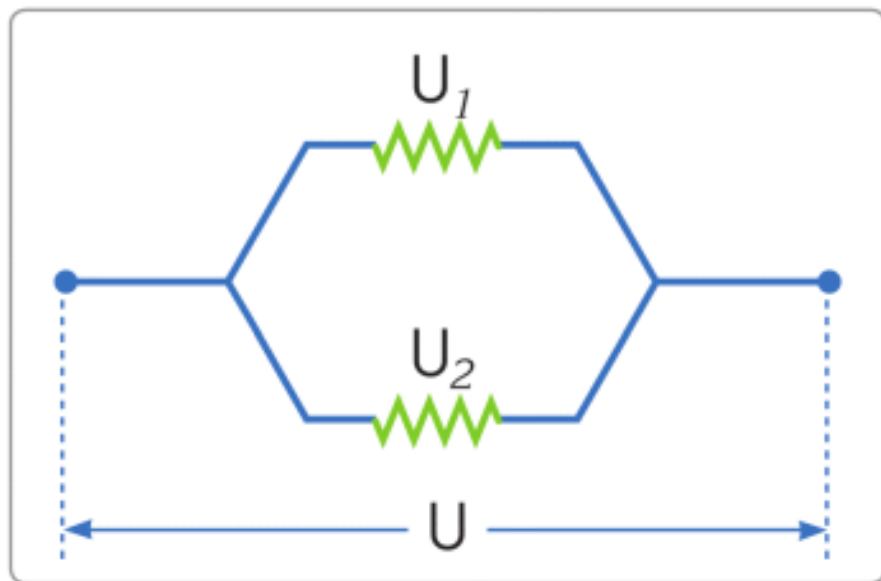

Figure 5

2. Тізбектегі толық ток күші әрбір резистордағы ток күштерінің қосындысына тең:

$I = I_1 + I_2$, Figure 6.

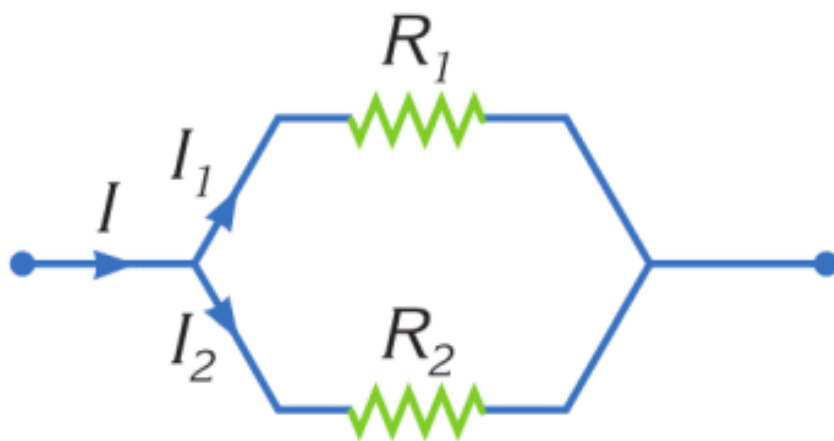

Figure 6

3. Тізбектегі толық кедергі ең кіші кедергінің мәнінен де төмен болады, Figure 7:



Figure 7

$$\frac{1}{R_{eq}} = \frac{1}{R_1} + \frac{1}{R_2}$$

Тізбектей қосу кезінде ток күші келесі элементке жету үшін бірінші элементтің бойынан өтуі тиіс. Бір элемент істен шықса, басқалары да жұмыс істемей қалады. Ескі гирляндalarda тізбектеп қосу қолданылған, Figure 8.

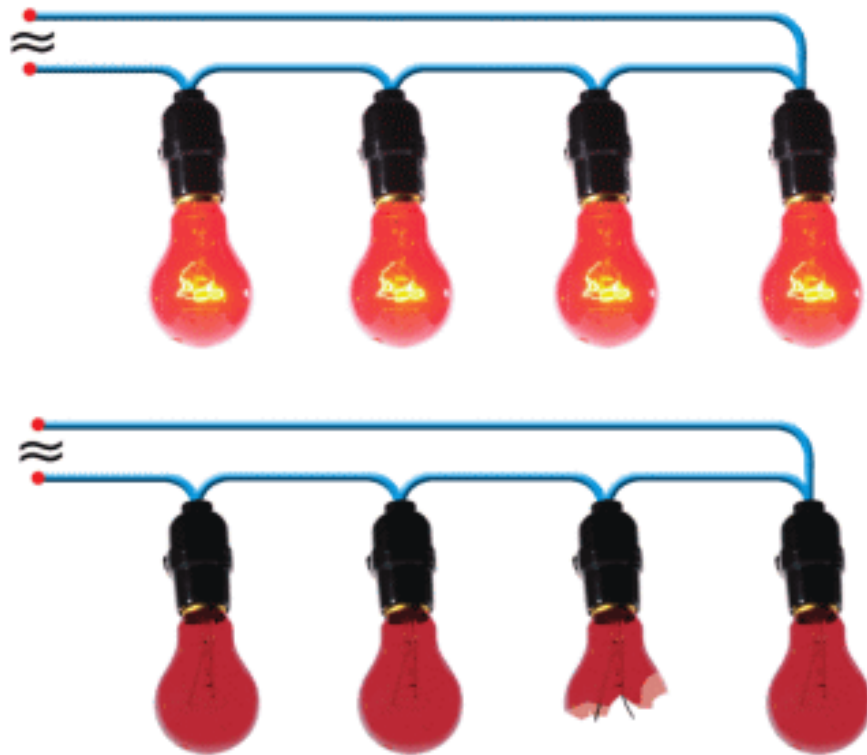

Параллель қосуда элементтердің әрқайсысы ток көзіне жалғанған. Бір элемент бұзылса, басқалары жұмыс жасай береді. Себебі ток күші тек бір жолдан жүрмейді, Figure 9.

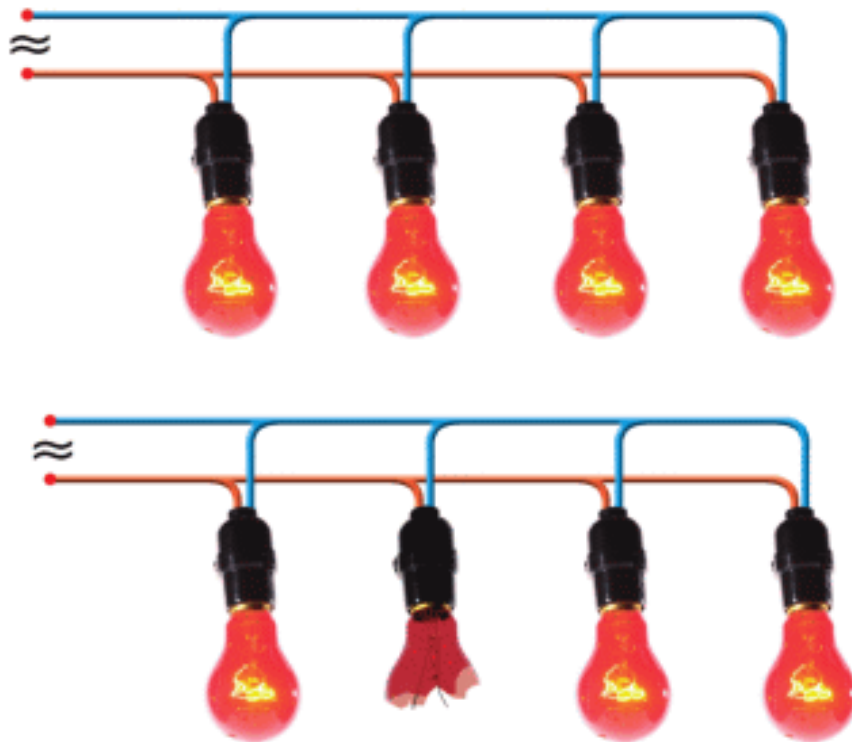

Параллель қосу машина шамдарында, көше шамдарында, үйлерде, кеңселерде, зауыттарда, электр станцияларында қолданылады. Мысалы, бір бөлік істен шығып қалса, басқалары токты тасымалдай береді.

FACT

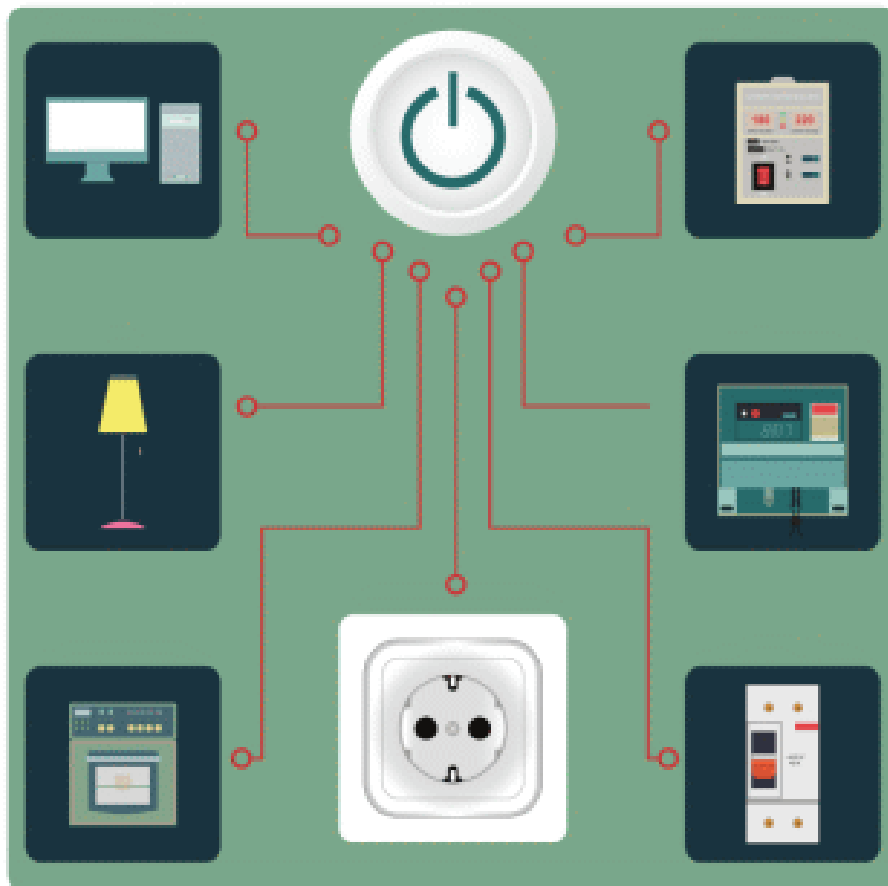

All devices in our house use a parallel connection, as shown in the figure.

EXAMPLE

Two 3 Ohm resistors are connected in series to a 6 Volts cell.

- Draw a circuit showing how they are connected.
- Calculate the equivalent resistance.
- Calculate the current in the main arm.
- Calculate the voltage on each resistor.

Solution:

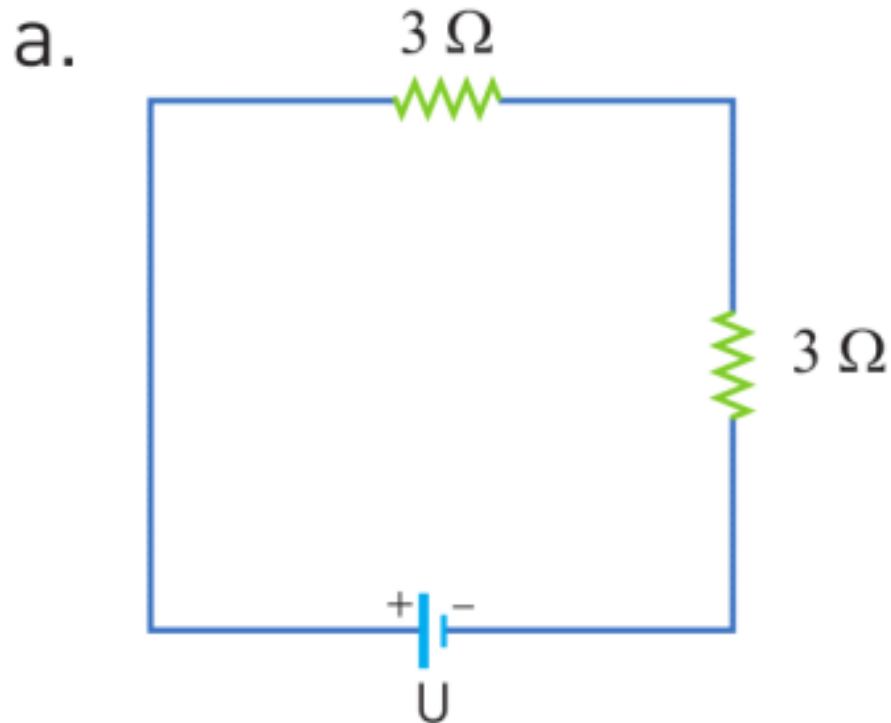

b. $R_{eq} = R_1 + R_2 = 3 + 3 = 6\Omega$

c. Because it is a series connection, currents are equal.
So we can write $I_1 = I_2 = I$

$$U = I \times R_{eq} \Rightarrow I = \frac{U}{R_{eq}} = 1A$$

d. $U_1 = I_1 \times R_1 = 1 \times 3 = 3V$
 $U_2 = I_2 \times R_2 = 1 \times 3 = 3V$

EXAMPLE

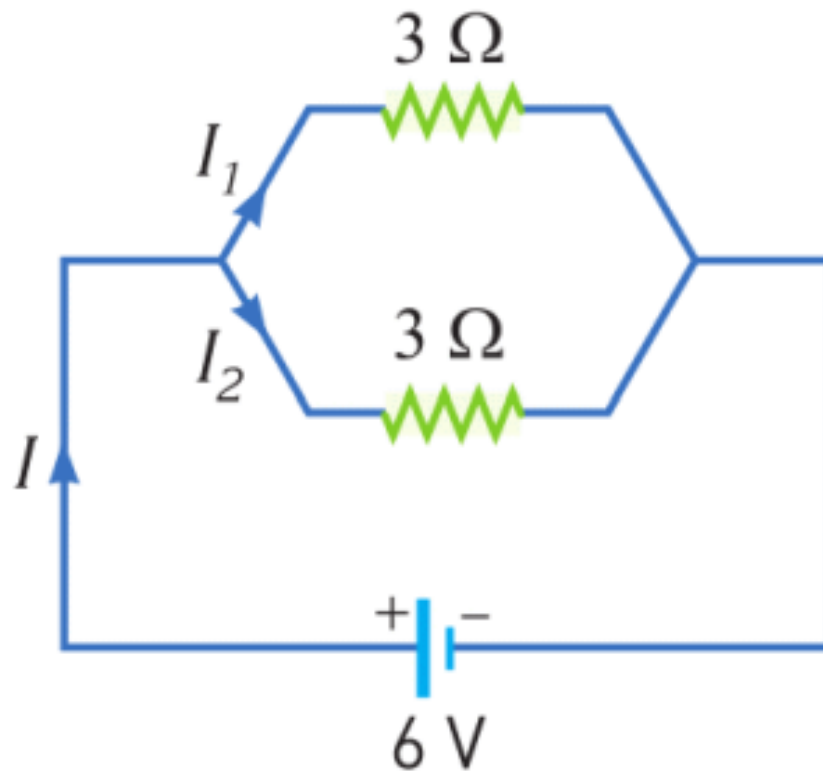

Calculate the equivalent resistance of the circuit.

Solution:

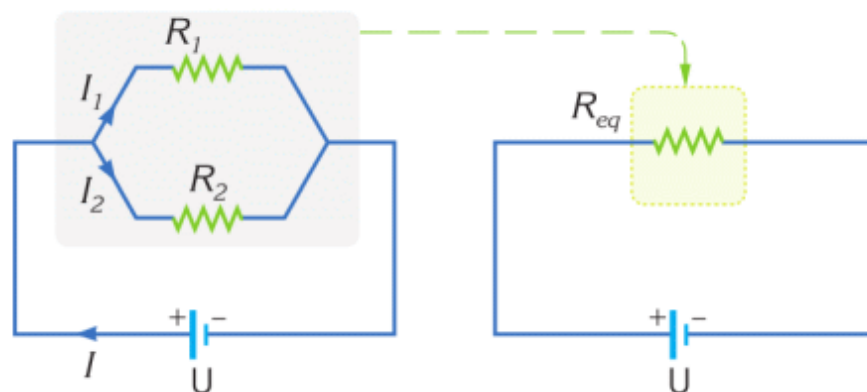

$$\frac{1}{R_{eq}} = \frac{1}{R_1} + \frac{1}{R_2} = \frac{1}{3} + \frac{1}{3} = \frac{2}{3}; \quad R_{eq} = 1.5\Omega$$

RESEARCH TIME

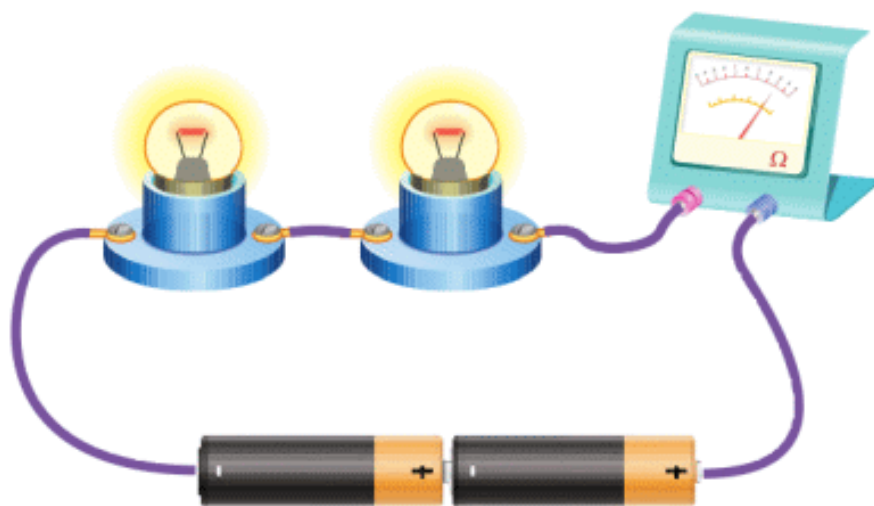

Construct the following circuit. Record brightness. What happens when you remove one of the bulbs?

LITERACY

1. Why is a parallel connection used in houses? Why is a series connection not used in houses?
2. Electric kettle uses 10 Amperes current. You plug in three kettles at once. How many Amperes do you need? Is it safe to use many devices? Is there any danger?
3. Electric kettle uses 10 Amperes and 220 Volts. You plug in three kettles. What is the equivalent resistance of three kettles? Why is it lower than a resistance of one kettle?

ART TIME

Imagine you are a leader of 20 employees. How do you construct relationships with them? Can you make an analogy with types of combination of resistors? Is it easier to make connections with each of them? Or make leaders for smaller teams?

TERMINOLOGY

- combination – қосылу / соединение
- series – тізбектей / последовательный
- parallel – параллель / параллельный

5.6 ELECTRICAL ENERGY AND POWER

YOU WILL:

- - apply formulas of electric power and electric work for problem solving.

QUESTION



Look at the Figure 1. This device is called electricity meter. Why do we need it?

ELECTRIC POWER AND ENERGY

Электр құрылғылардың жұмыс атқарулары үшін энергия қажет. Әр құрылғы әртүрлі шамада энергия тұтынады. Сондықтан, қуат түсінігін қолдануымызға тура келеді. Келесі тапсырмаға назар аударыңыз.

ACTIVITY

Кестеде 3 түрлі USB зарядтау жабдығының сипаттамалары берілген.

USB зарядтау жабдықтарындағы ток күші, кернеу және кедергілері арасында қандай қарым-қатынас көріп тұрсыз?

USB power standards	Current (Amperes)	Voltage (Volts)	Power (Watts)
Low-power device (USB 2.0)	0.1 A	5 V	0.50 W
High-power device (USB 3.0)	0.5 A	5 V	2.5 W
Type-C	3 A	5 V	15 W



USB 2.0



USB 3.0



Type-C

What relationship do you see between current, voltage and power?

Жоғарғы кестеден:

$$\text{Current} \times \text{Voltage} = \text{Power}$$

$$\text{Ampere} \times \text{Volt} = \text{Watt}$$

$$I \times U = P$$

$$\begin{aligned} \text{Current} \times \text{Voltage} &= \text{Power} \\ \text{Ampere} \times \text{Volt} &= \text{Watt} \\ I \times U &= P \end{aligned}$$

Уақыт бірлігі ішінде тұтынылған (жұмсалған) энергия қуат деп аталады. Қуаттың өлшем бірлігі Ватт (Вт). 1 Ватт = 1 Джоуль/секунд Осыдан қуат, энергия және уақыт арасындағы байланыс келесідей болады:

$$\text{Energy} = \text{Power} \times \text{time}$$

$$E = P \times t$$

$$\begin{aligned} \text{Energy} &= \text{Power} \times \text{time} \\ E &= P \times t \end{aligned}$$

Table 5.6-да кейбір құрылғылардың қуаттары берілген.

Device	Power
Air conditioner	5000W
Cooker	4000 W
Kettle	2200 W
Iron	1600 W
Microwave	1500 W
Drill	360 W
LCD TV	213 W
25" color TV	150 W
19" color TV	70 W
Light bulb	100-60-32-18 W

Table 5.6

JOULE-LENZ LAW

Джоуль-Ленц заңы Ток өткізгіш бойымен өткенде өткізгіш қыза бастайды. Бұл қозғалыстағы электрондардың өткізгіш атомдарымен соқтығысуынан болады.

Соқтығысулар өткізгіш атомдардың жылулық тербелісін арттырады. Нәтижесінде өткізгіш қызады. Осыдан шығатын қорытынды, ток күші өткізгіштердің бойымен өткенде, өткізгіштен сыртқа жылулық энергия бөлінеді.

Токтың атқарған жұмысы Джоуль-Ленц заңы арқылы анықталады.

$$Q = I^2 \times R \times t$$

$$Q = I^2 \times R \times t$$

Here:

Q-heat produced by electric current [J]

I-electric current [A]

R- resistance [Ohm]

t-time [s]

ACTIVITY

Electricity at home

People pay for the electric energy they consume at home. The energy is calculated using different unit: kilowatt-hours.

$$1 \text{ kW} \times \text{h} = 1000 \text{ W} \times \text{h}$$

$$1000 \text{ W} \times \text{h} = 1000\text{W} \times 3600 \text{ s}$$

$$1000\text{W} \times 3600 \text{ s} = 3\,600\,000 \text{ J}$$

The pricing is different everywhere. For example, in some cities, 1kWh costs 16.89 KZT.

Let us calculate the cost of electrical energy consumed by iron of 1600 W in 3 minutes.

a) We need to find how many kWh the iron consumed.

$$1600 \text{ W} = 1.6 \text{ kW}$$

$$2 \text{ min} = 0.05 \text{ h}$$

$$1.6 \text{ kW} \times 0.05 \text{ h} = 0.08 \text{ kWh}$$

Then, the cost is

$$0.08 \times 16.89 = 1.3512 \text{ KZT}$$

Tasks:

a) Choose any 3 devices from the table 5.6 and calculate the cost of electricity. Use the internet to find energy rates in your region.

b) 1.3512 KZT is not much. It seems that tariffs are quite cheap. Why does then an average family of 4 people get electricity bills for 4-5 thousand KZT per month?

EXAMPLE

Electric kettle with the resistance of 22Ω is used to heat 2 kg of water. If the initial temperature of the water is 25°C , how much time later will the water boil?

$c_{\text{water}} = 4200 \text{ J/kg}^\circ\text{C}$. The kettle uses 220 V voltage.

Solution:

a) Electric current produces heat : $Q = I^2 \times R \times t$.

b) This heat is absorbed by water : $Q = m \times c \times \Delta T$.

c) We can equalize these equations and solve for t.

$$I^2 \times R \times t = m \times c \times \Delta T$$

d) Electric current:

$$I = 220 \text{ V} / 22 \text{ } \Omega.$$

e) Change in temperature is

$$\Delta T = 100 - 25 = 75^\circ\text{C}$$

$$10^2 \times 22 \times t = 2 \times 4200 \times 75$$

Answer: $t = 286.36$ seconds or $t = 4.8$ minutes

EXAMPLE

A WiFi router works with 9 V voltage and 0.85 A current. Router works 5 days per week and 8 hours per day. How much energy does the router use in 1 month? (1 month = 4 weeks)

Solution:

Power of router:	$P = I \times V \Rightarrow P = 3.5 \times 220 = 770 \text{ W}$
Time of works in one month:	$4 \text{ weeks} \times 5 \text{ days} \times 8 \text{ hours} = 160 \text{ hours}$
Time in seconds:	$160 \text{ hours} \times 60 \text{ min} \times 60 \text{ sec} = 576,000 \text{ seconds}$
Energy formula:	$E = P \times t \Rightarrow E = 770 \times 576,000 = 4\,406\,400 \text{ J}$

RESEARCH TIME

How would you calculate kWh-s that you use at home without using electricity meter?

FACT

EAES Ekibastuz thermal power station has the tallest chimney (about 420 meters) in the world. It uses coal to produce electrical power of 1000 MW, and it powers north regions of Kazakhstan and Baikonur spaceport. It also uses the highest transmission voltage in the world (1150 kV).

LITERACY

1. An electronic book uses 5 Volts and 1 Ampere. How many Watts of power does the electronic book use?
2. An electric kettle uses 220 Volts and 10 Amperes. How many Watts of power does the kettle use? Why do the kettle and the e-book have different powers?
3. Why do we use kWh in electricity bills? Why do we not use Joules?
4. The electric kettle uses 220 Volts and 10 Amperes. It works for 5 minutes. How many kWh does it use? How many Joules does it use? (1 kWh = 1 kiloWatt hour = 3600000 J).

ART TIME

Make a sculpture that shows “electric power”. Make the sculpture and show it to parents, teachers and friends.

TERMINOLOGY

- power – қуат / мощность

- charger cable - зарядтағыш кабелі/ кабель для зарядного устройства

5.7 SHORT CIRCUIT

YOU WILL:

- - explain conditions for short circuit and describe methods of preventing of short circuit.

QUESTION



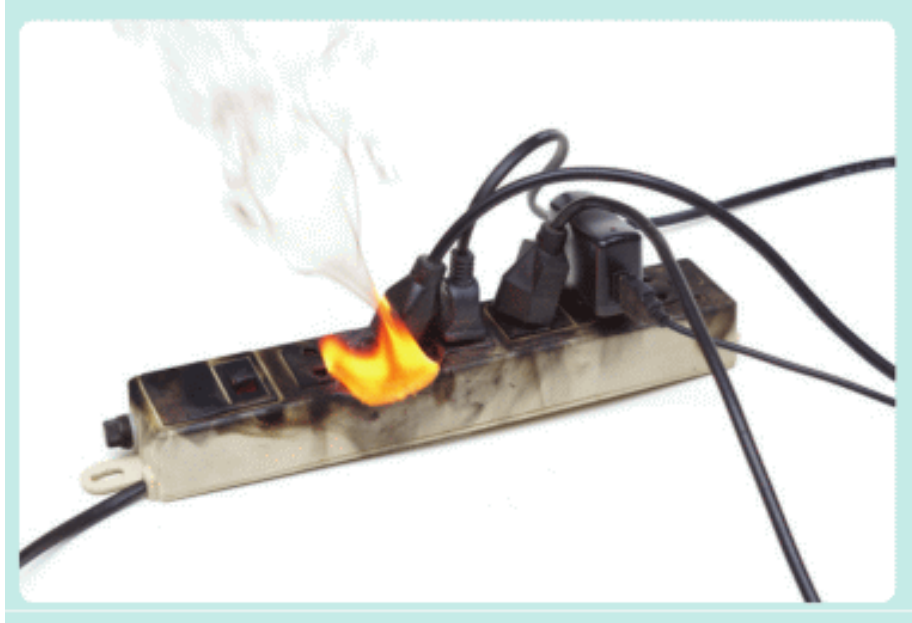

Sometimes electric devices burn. What may be the reason of it?

SHORT CIRCUIT

Қысқа тұйықталу кезінде тізбектегі ток күші күрт артады. Бұндай токтың әсерінен сымдар қызып, өрт шығуы мүмкін. Алайда, оның алдын алудың жолы бар. Ол үшін балқымалы сақтандырғыш электр құралы пайдаланылады. Оның міндеті - ток күші артқанда қызып, балқу арқылы тізбекті ажырату, Figure 1. Осылайша құрылғылар әртүрлі зақымнан қорғалған болады.

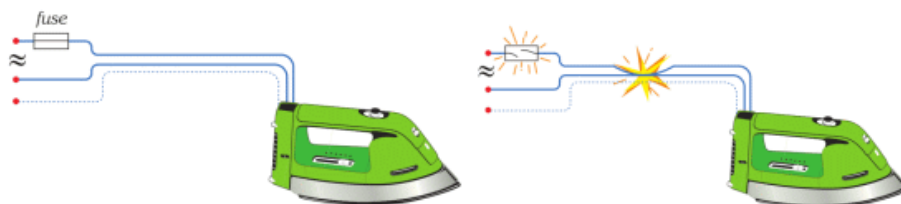

Figure 1

Балқымалы сақтандырғыш шағын шыны түтік пен жіңішке сымнан құралады. Бұл сымның кедергісі жоғары болғанымен, балқу температурасы төмен болып табылады, Figure 2, 3.

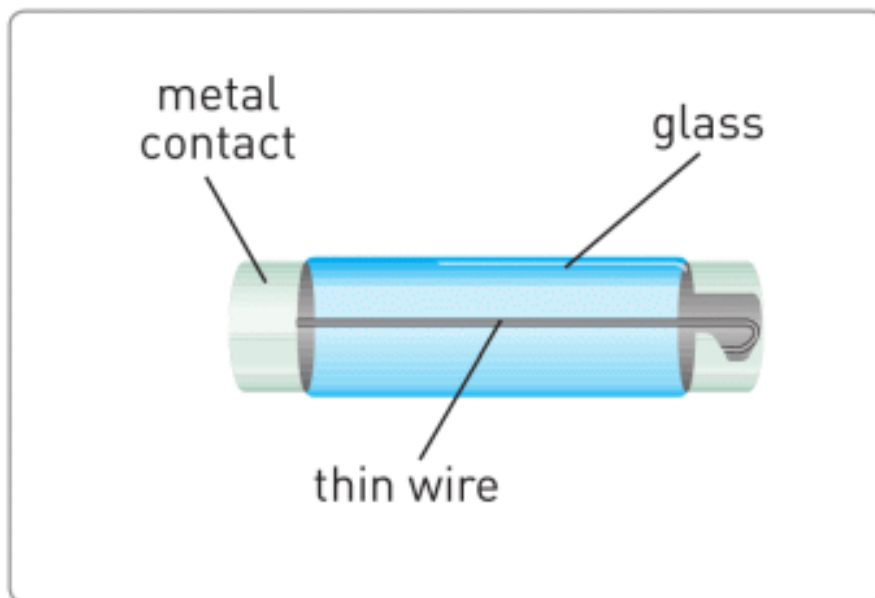

Figure 2

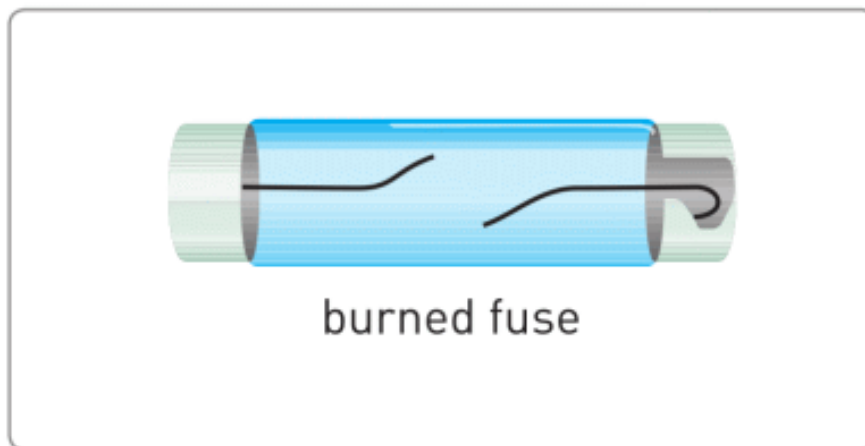

Figure 3

CIRCUIT BREAKER

Бұл сақтандырғыштың басқа бір түрі. Тізбектегі ток күші тым жоғары болған кезде аталмыш сақтандырғыш кілттің қызметін атқарып, тізбекті ажыратады.



Figure 4

DISCUSSION



In summer, electric stations send more electric energy to consumers. Why? (Use information about resistance-temperature dependence at page 87).

EXAMPLE

The following devices are operating in a kitchen circuit:

- 50 W fruit blender
- 400 W refrigerator
- 800 W microwave oven
- 1.5 kW electric kettle

The electricity supply is 220 V. Circuit breaker has a rating of 20 A.

What is the current flowing through the circuit breaker? Does the circuit break? Why?

Solution:

The total power: $P = 50 + 400 + 800 + 1500 = 2750 \text{ W}$

Then we should find current:

$$P = I \times V \Rightarrow I = \frac{P}{V} = \frac{2750}{220} = 12.5 \text{ A}$$

Current is lower than the circuit breaker rating. That is why circuit does not break.

RESEARCH TIME

Material: 9 V battery, wire, 2 small bulbs

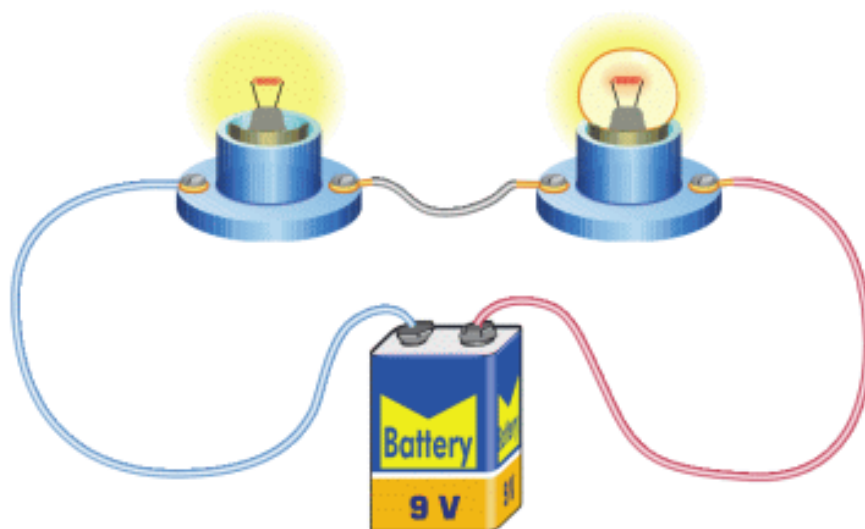

Procedure: take 1 lamp and remove the glass carefully so that the filament is not damaged.

Connect them as shown in the picture. Blow to the filament. What is happening? What is the reason?

FACT

When a fuse burns out, firstly a technician must find the fault and fix it. Then the technician must replace the fuse with a new one.

LITERACY

1. Why do people use fuses in electronics? How do fuses work? What materials can you use to make a fuse?
2. Why do people use circuit breakers in electrical systems? How do circuit breakers work? What materials can you use to make circuit breaker?
3. What are the differences between fuses and circuit breakers? Can you list advantages and disadvantages of fuses and circuit breakers?
4. Why does a hot wire have bigger resistance than a cold wire? How do atoms move in the hot wire? How do atoms move in the cold wire?
5. How do atoms move when the temperature becomes lower than $-250\text{ }^{\circ}\text{C}$? Why does resistance become small when the temperature becomes lower than $-250\text{ }^{\circ}\text{C}$?

TERMINOLOGY

- circuit breaker – тізбек ажыратқыш / автоматический выключатель
- filament – қызба қылы / нить накаливания fuse – сақтандырғыш / предохранитель

5.8 ELECTRIC CURRENT IN LIQUIDS AND GASES

YOU WILL:

- - explain nature of electric current in liquids.

QUESTION



Why is it dangerous to deal with electricity when your hands are wet?

ELECTRIC CURRENT IN LIQUIDS AND GASES

Электр тогы тұщы суға қарағанда тұзды судан жақсы өтеді. Не себепті? Себебі тұзды судың құрамында тұщы суға қарағанда иондар көбірек болады. Бұл иондар суда ерітілген тұздардан пайда болады.

Ас тұзының химиялық формуласы NaCl . Судың ішінде тұз молекуласы Na^+ (оң зарядталған ион) және Cl^- (теріс зарядталған ион) болып екіге бөлінеді. Figure 2. Na^+ ионы батареяның теріс жағына ұмтылады, ал Cl^- ионы оң жағына ұмтылады. Тұзды судың ішіндегі иондардың (Na^+ және Cl^-) бағытталған қозғалыстары электр тогын тудырады.



Figure 1

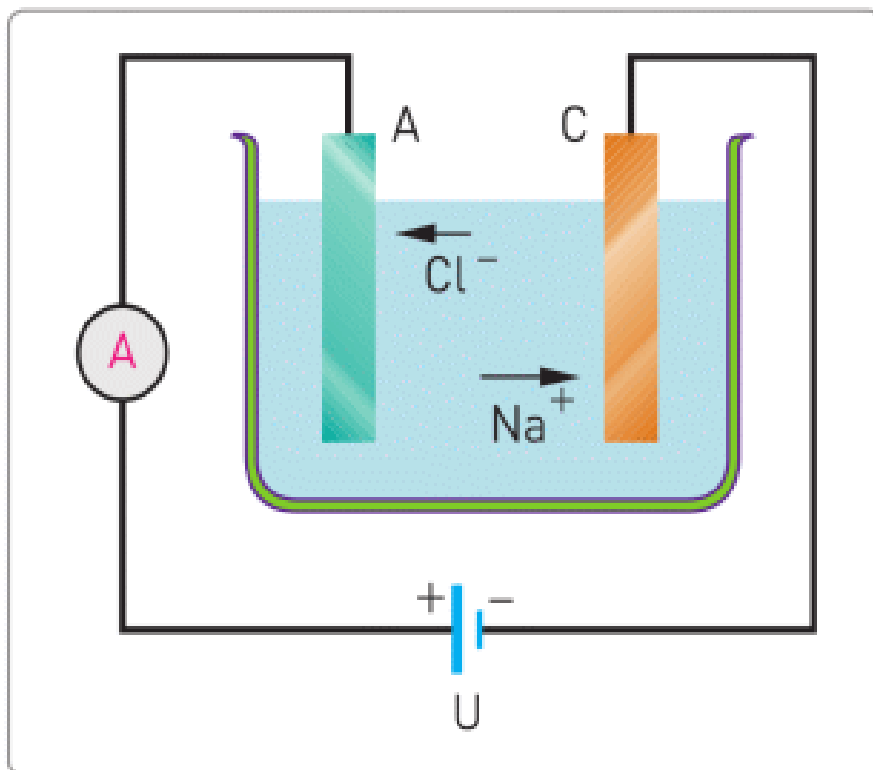

Figure 2

Figure 1, 2 көрсетілгендей, Cl^- батареяның оң жағына (Анод, белгісі А) барады, ал Na^+ батареяның теріс жағына (Катод, белгісі С) барады. Бұл процесс электролиз деп аталады. Яғни, ерітінді арқылы тура тоқтың өтуінде электролиз құбылысы орын алады. Электролиз процесі өндірісте кеңінен қолданылады.

Electrolysis is used in industry and art, Figure 5. Electroplating, electroforming, and electrotyping are types of the electrolysis.



a



b

Figure 5. Electroplated leaves and coffee beans (a), electroplated nuts and bolts (b)

On the Figure 3 copper plate is submerged in liquid. Then copper atoms in liquid (positive) go to key (negative). As a result, copper covers the surface of the key. Key becomes electroplated with copper. This process is called electroplating and it is used to cover the surface of one metal with a thin layer of another metal. Electroplating protects metal from corrosion (rust), Figure 4.

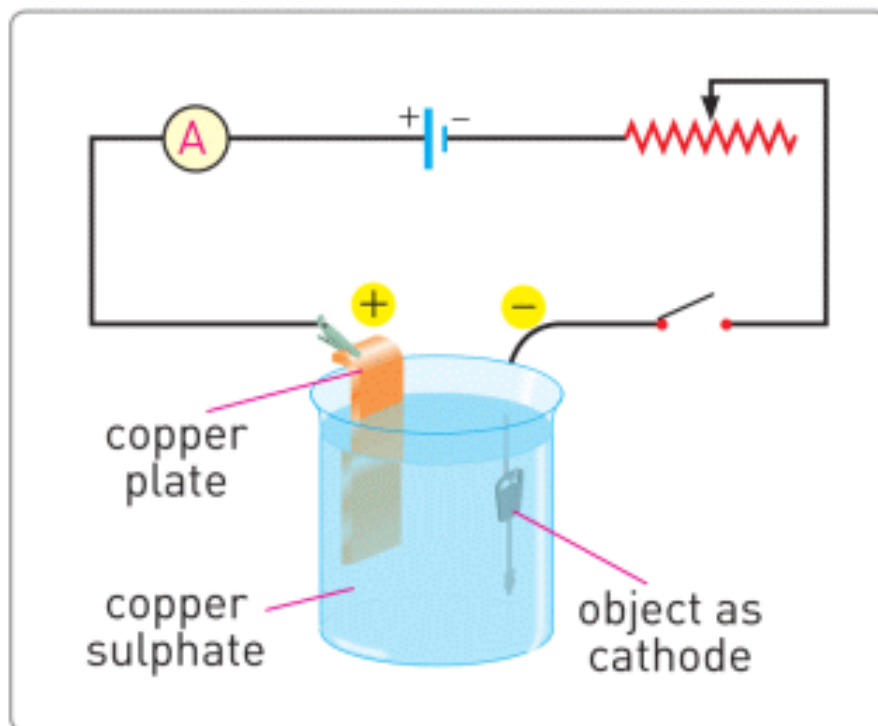

Figure 3



Figure 4. Corrosion (rust) of nut and bolt (a), car (b)

FACT

Fluorescent lamp.



In fluorescent lamps, current flows through a gas. The mercury vapour in fluorescent lamps is toxic.

ACTIVITY

Material: 2 connecting wires, wide jar, baking soda, water, 9V battery.

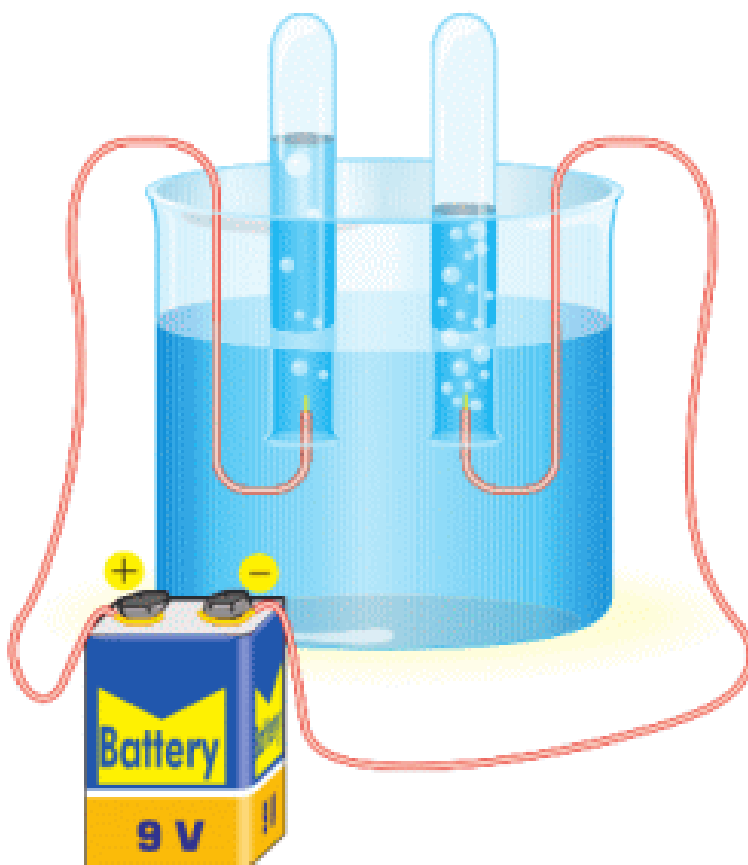

Procedure: put some water into the jar. Pour baking soda in to the water and mix. Connect the wire to the terminal of battery and put them into water. You can see bubbles forming at the end of the wire. What gases are they?

LITERACY

1. Why do we use electrotyping? How can you do electrotyping?
2. Why do we use electroforming? How can you do electroforming?

3. Why do people use chrome plating in cars and motorcycles? How can you do chrome plating?



4. How does electric current travel when lightning strikes seawater (saltwater)? Is lightning dangerous for sea fish?
5. Chlorine (symbol: Cl) is a toxic gas. It kills harmful bacteria. That is the reason why chlorine is used to disinfect water. How can you produce chlorine? Hint: Salt is NaCl.
6. Some cars use very bright “xenon headlights”. Why do they use xenon gas? How does “xenon headlights” produce light?

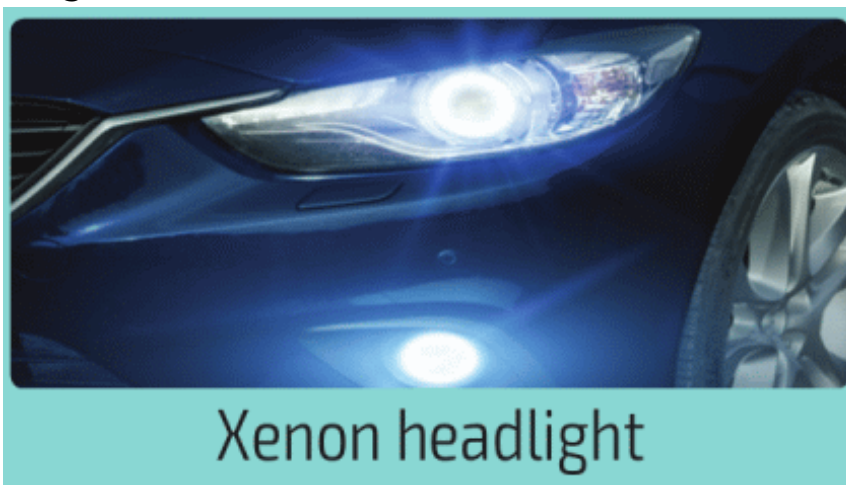

Xenon headlight

7. Why does plasma lamp need electricity to give light?
How does plasma lamp work?

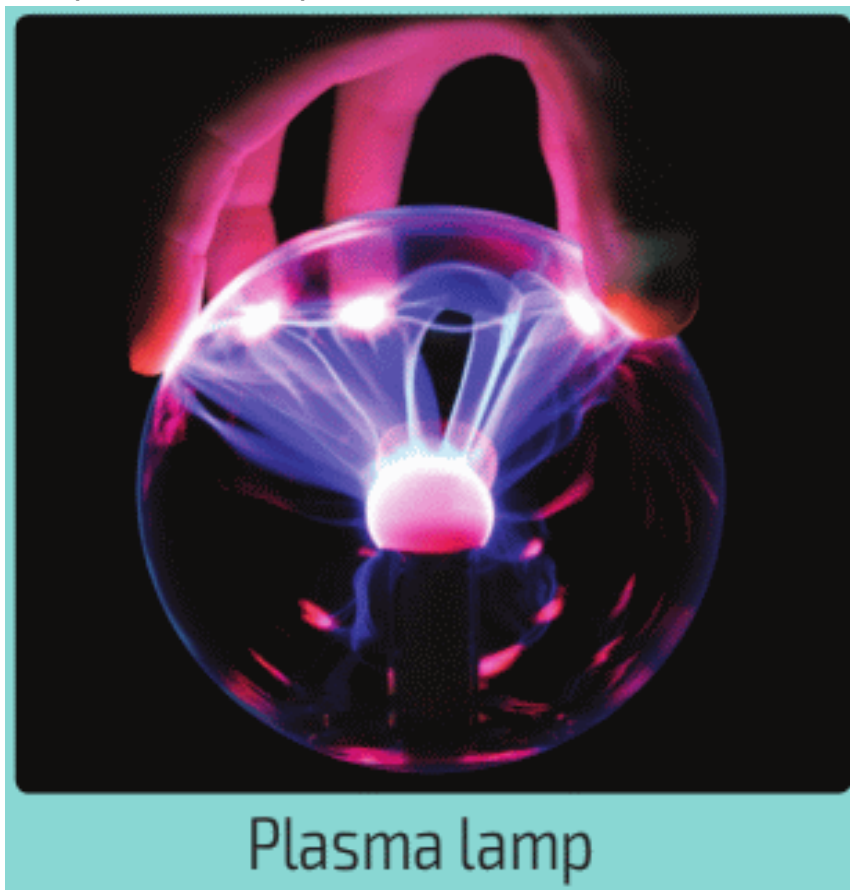

ART TIME

Prepare a flash mob that explains electrolysis. What ideas can you use? Make the flash mob and show it to parents, teachers, and friends.

TERMINOLOGY

- fluorescent – люминесценттік / люминесцентный
- toxic – уытты / токсичный
- to dissolve – еру / растворяться

LABWORK 3

TITLE:

Electric current and voltage

OBJECTIVES:

- Measure electric current and voltage.
- Apply the Ohm's law to determine resistance.

MATERIALS LIST:

1. power source (or battery)
2. resistor (or light bulb)
3. ammeter
4. voltmeter (or multimeter)
5. connecting wires
6. switch

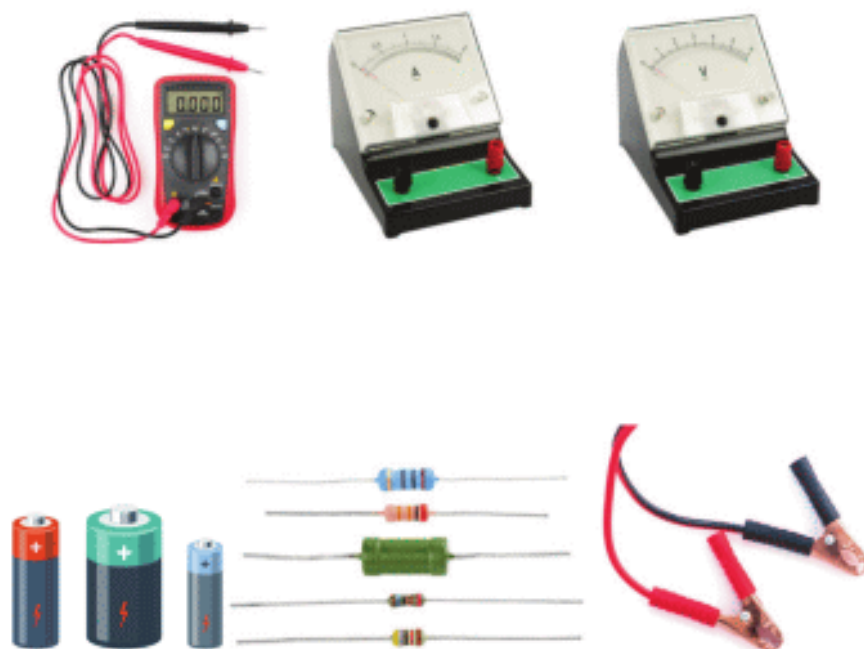

SAFETY:

1. Never close a circuit until it has been approved by your teacher. Never rewire or adjust any element of a closed circuit. Never work with electricity near water; be sure the floor and all work surfaces are dry.
2. If the pointer on any kind of meter moves off the scale, open the circuit immediately by opening the switch.
3. Do not attempt this exercise with any batteries or electrical devices other than those provided by your teacher for this purpose.
4. Use a hot mitt to handle resistors, light sources, and other equipment that may be hot. Allow all equipment to cool before storing it.

THEORY:

- $V = I \times R$

- What is V ? What is the unit of measurement of V ?
- What device does measure V ?
- What is I ? What is the unit of measurement of I ?
- What device does measure I ?
- What is R ? What is the unit of measurement of R ?
- What device does measure R ?
- Why does electric current flow through the circuit?
- Why does electric current increase when the voltage increases?
- Why does electric current decrease when the voltage decreases?

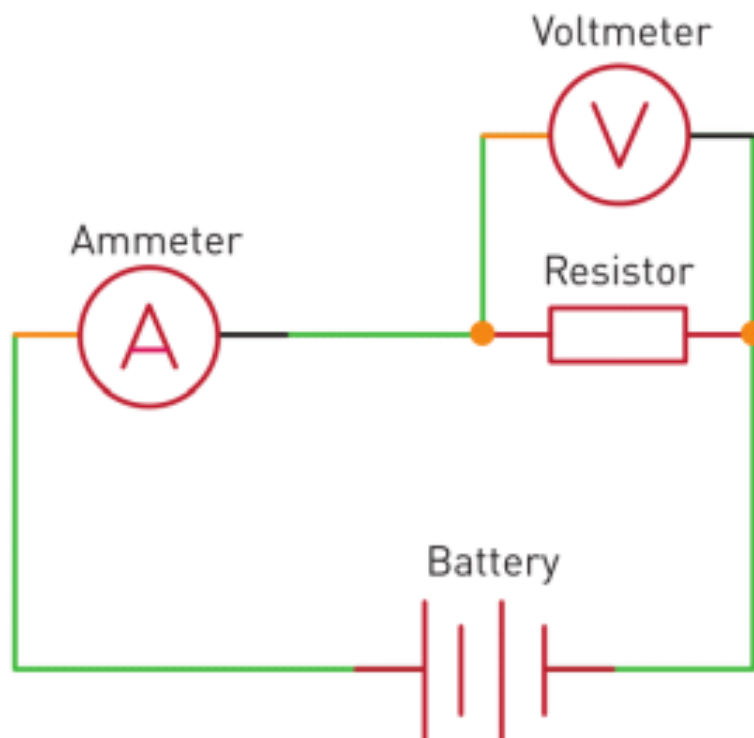

PROCEDURE:

1. Read the entire lab PROCEDURE, and plan the steps YOU WILL take.
2. Record your data in the data table.
3. Set up the apparatus as shown in Figure. Construct a circuit that includes a power supply, a switch, a current meter, a voltmeter, and the resistance. Do not turn on the power supply. Do not close the switch until your teacher has approved your circuit.
4. With the switch open, connect the current meter in a straight line in series with the resistance.
5. When your teacher has approved your circuit, make sure the power supply dial is turned completely counter clockwise. Turn on the power supply, and slowly turn the dial clockwise.
5. Periodically close the switch briefly and read the current value of the current meter.
6. Close the switch. Quickly record the current and the potential difference across the resistance in your data table. Open the switch immediately.
7. Turn off the power supply by turning the dial completely counter clockwise.
8. Clean up your work area. Put equipment away safely.

ANALYSIS:

1. $V =$ _____ Volts
2. $I =$ _____ Amperes
3. $R =$ _____ Ohms

CONCLUSIONS:

When the voltage is doubled current doubles too. Explain why.

LABWORK 4

TITLE:

Current-voltage relationship (or I-V curve)

OBJECTIVES:

- Measure current and voltage.
- Apply the Ohm's law to determine resistance.
- Draw current-voltage relationship (or I-V curve)

MATERIALS LIST:

1. power source (or battery)
2. resistor (or light bulb)
3. ammeter
4. voltmeter (or multimeter)
5. connecting wires
6. switch

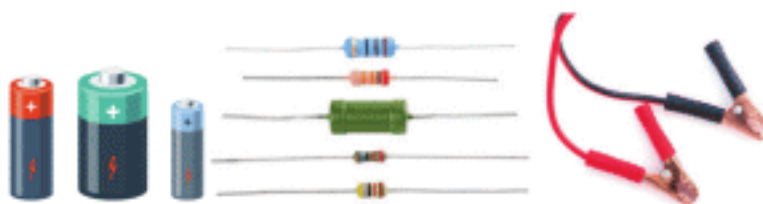

SAFETY:

1. Never close a circuit until it has been approved by your teacher. Never rewire or adjust any element of a closed circuit. Never work with electricity near water; be sure the floor and all work surfaces are dry.
2. If the pointer on any kind of meter moves off scale, open the circuit immediately by opening the switch.
3. Do not attempt this exercise with any batteries or electrical devices other than those provided by your teacher for this purpose.
4. Use a hot mitt to handle resistors, light sources, and other equipment that may be hot.
5. Allow all equipment to cool before storing it.

THEORY:

$$V = I \times R$$

1. What is V? What is the unit of measurement of V?
2. What device does measure V?
3. What is I? What is the unit of measurement of I?
4. What device does measure I?
5. What is R? What is the unit of measurement of R?
6. What device does measure R?
7. Why does electric current flow through circuit?
8. Why does electric current increase when voltage increases?
9. Why does electric current decrease when voltage decreases?

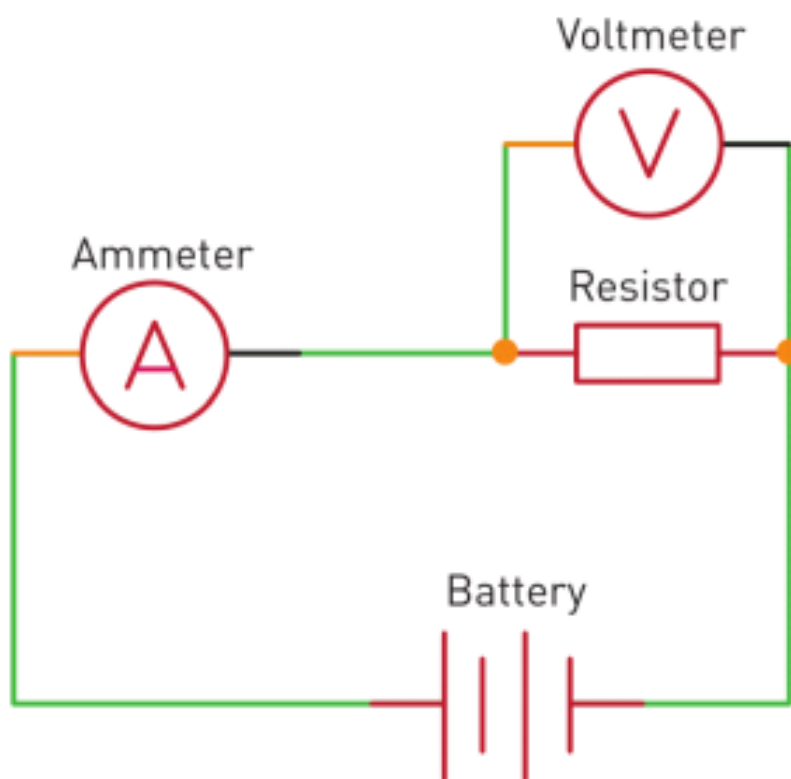

PROCEDURE:

1. Read the entire lab PROCEDURE, and plan the steps YOU WILL take.
2. Record your data in the data table.
3. Set up the apparatus as shown in Figure. Construct a circuit that includes a power supply, a switch, a current meter, a voltmeter, and the resistance. Do not turn on the power supply. Do not close the switch until your teacher has approved your circuit.
4. With the switch open, connect the current meter in a straight line in series with the resistance.
5. When your teacher has approved your circuit, make sure the power supply dial is turned completely counter clockwise. Turn on the power supply, and slowly turn the dial clockwise. Periodically close the switch briefly and read the current value on the current meter.
6. Close the switch. Quickly record the current and the potential difference across the resistance in your data table. Open the switch immediately. Turn off the power supply by turning the dial completely counter clockwise.
7. Repeat step 6 until you fill the table.
8. Clean up your work area. Put equipment away safely.

ANALYSIS:

Voltage (Volts)	Electric current (Amperes)

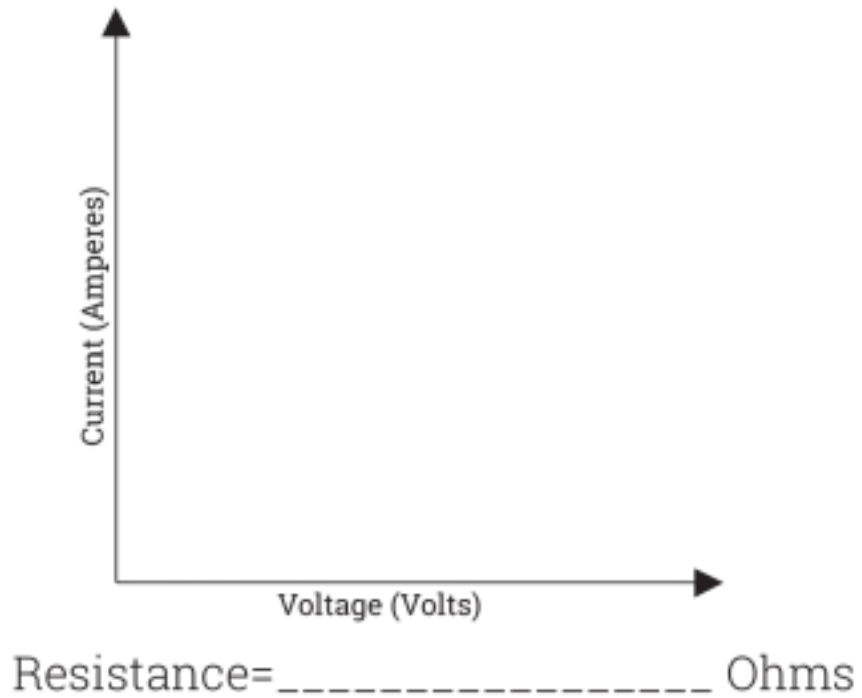

CONCLUSIONS:

Explain why the line in the graph is straight (or curved)?

LABWORK 5

TITLE:

Series connection of resistors

OBJECTIVES:

- Measure current and potential difference across resistors in series.
- Find the unknown resistance of two resistors.
- Calculate the equivalent resistance.
- Analyse the relationship between potential difference, current, and resistance in a circuit.

MATERIALS LIST:

1. power source (or battery)
2. resistor (or light bulb)
3. ammeter
4. voltmeter (or multimeter)
5. connecting wires
6. switch

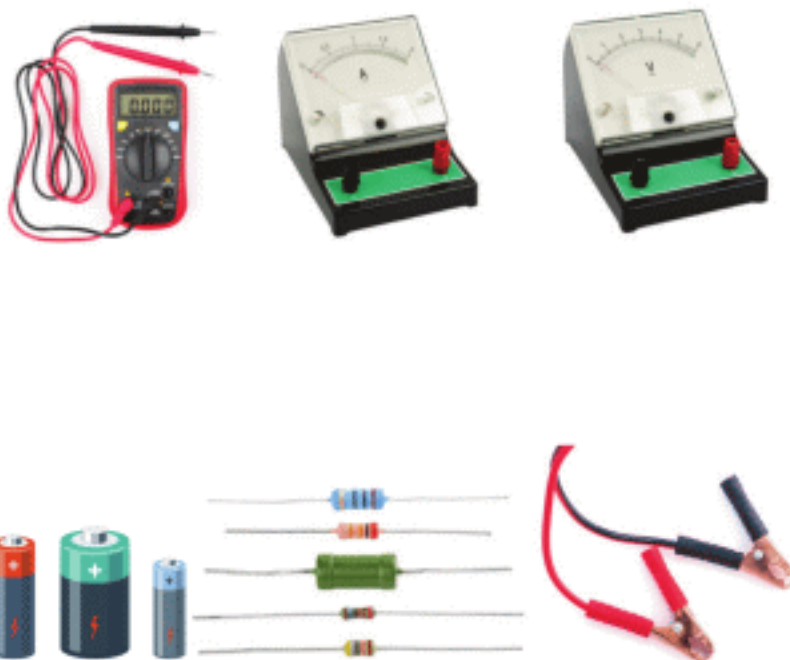

SAFETY:

1. Never close a circuit until it has been approved by your teacher.
2. Never rewire or adjust any element of a closed circuit.
3. Never work with electricity near water; make sure the floor and all work surfaces are dry.
4. If the pointer on any kind of meter moves off the scale, open the circuit immediately by opening the switch.
5. Do not attempt this exercise with any batteries or electrical devices other than those provided by your teacher for this purpose.
6. Use a hot mitt to handle resistors, light sources, and other equipment that may be hot. Allow all equipment to cool before storing it.

THEORY:

$$V = I \times R$$

1. What is V? What is the unit of measurement of V?
2. What device does measure V?
3. What is I? What is the unit of measurement of I?
4. What device does measure I?
5. What is R? What is the unit of measurement of R?
6. What device does measure R?
7. Why does electric current flow through the circuit?
8. Why does series connection of resistors decrease current?

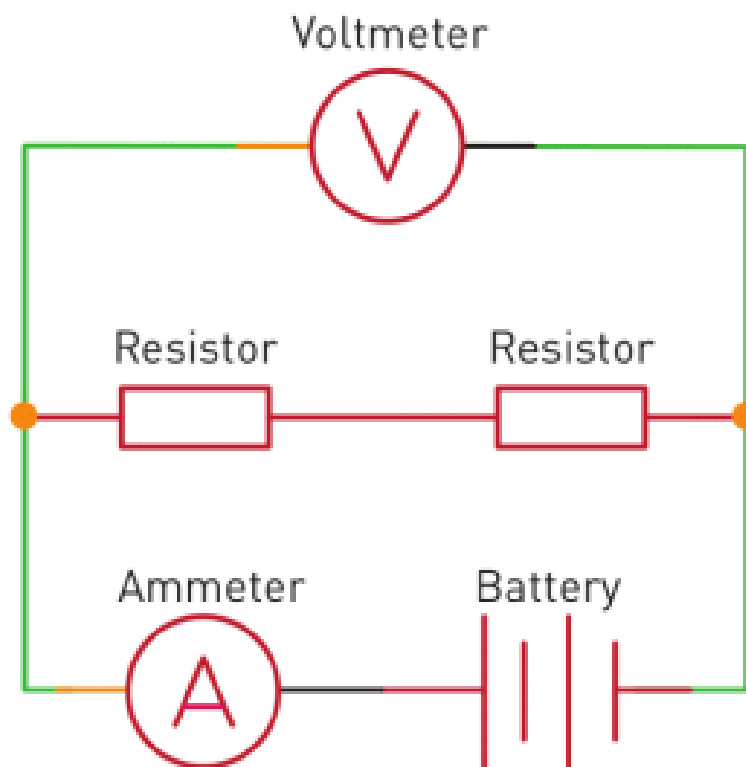

PROCEDURE:

1. Read the entire lab PROCEDURE, and plan the steps YOU WILL take.
2. Record your data in the data table.
3. Construct a circuit that includes a battery, a switch, and two unequal resistors in series. Do not close the switch until your teacher has approved your circuit.
4. With the switch open, connect the current meter in series and the voltage meter in parallel with one of the resistors. Do not close the switch.
5. When your teacher has approved your circuit, close the switch. Measure the current in and the potential difference across the resistor. Record the information in your data table. Open the switch.
6. Carefully remove the meters from the first resistor. Rewire the meters to measure the potential difference across and the current in the second resistor. Do not close the switch.
7. When your teacher has approved your circuit, close the switch. Measure the current in and the potential difference across the resistor, and record the information in your data table. Open the switch.
8. Leave the current meter in place, and carefully rewire the voltage meter to measure the potential difference across both resistors. Record this value in your data table.
9. Clean up your work area. Put equipment away safely.

ANALYSIS:

1. Using your measurements for potential difference and current, compute the resistance values of R_1 and R_2 in each circuit.
2. Compute the equivalent resistance R_{eq} using the values found in item 1.
3. Explain how the combination of resistors affects the total resistance in the circuit.

4. Explain how the combination of resistors affects the total current in the circuit.

CONCLUSIONS:

Compare the total current in each circuit with the current in each resistor. What is the relationship between the current in an individual resistor and the total current in the circuit?

LABWORK 6

TITLE:

Parallel connection of resistors

OBJECTIVES:

- Measure current and potential difference across resistors in parallel.
- Find the unknown resistances of two resistors.
- Calculate equivalent resistances.
- Analyse the relationships between potential difference, current, and resistance in a circuit.

MATERIALS LIST:

1. power source (or battery)
2. resistor (or light bulb)
3. ammeter
4. voltmeter (or multimeter)
5. connecting wires
6. switch

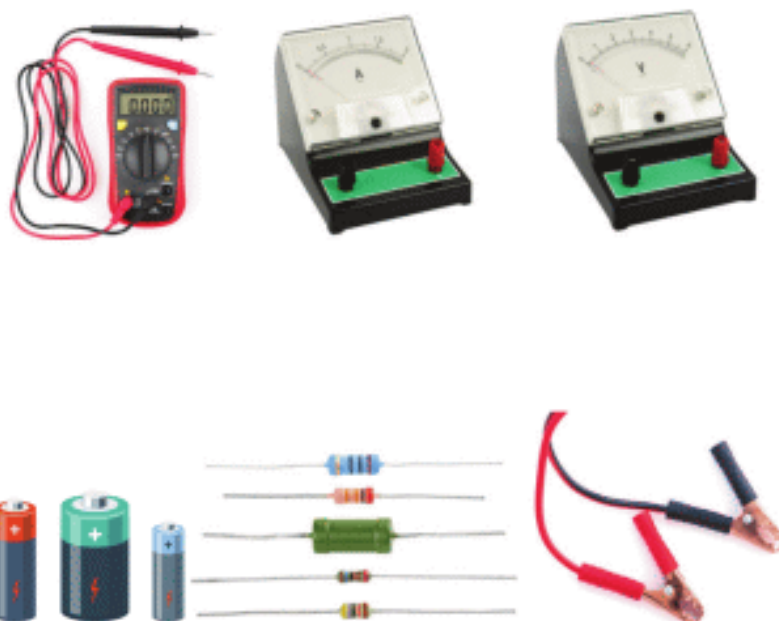

SAFETY:

1. Never close a circuit until it has been approved by your teacher.
2. Never rewire or adjust any element of a closed circuit.
3. Never work with electricity near water; make sure the floor and all work surfaces are dry.
4. If the pointer on any kind of meter moves off scale, open the circuit immediately by opening the switch.
5. Do not attempt this exercise with any batteries or electrical devices other than those provided by your teacher for this purpose.
6. Use a hot mitt to handle resistors, light sources, and other equipment that may be hot. Allow all equipment to cool before storing it.

THEORY:

$$V = I \times R$$

1. What is V? What is the unit of measurement of V?
2. What device does measure V?
3. What is I? What is the unit of measurement of I?
4. What device does measure I?
5. What is R? What is the unit of measurement of R?
6. What device does measure R?
7. Why does electric current flow through the circuit?
8. Why does series connection of resistors decrease current?

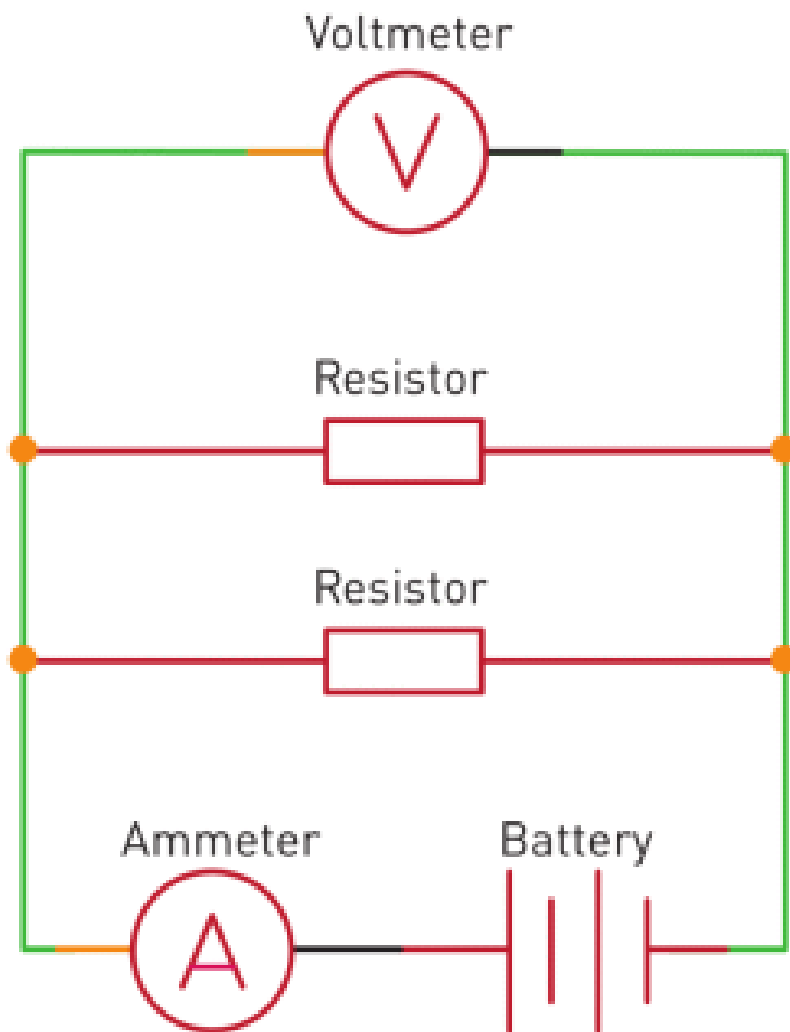

PROCEDURE:

1. Read the entire lab PROCEDURE, and plan the steps YOU WILL take.
2. Record your data in the data table.
3. Construct a circuit containing a power supply, a switch, and the two resistors wired in parallel, as shown in Figure. Do not close the switch until your teacher has approved your circuit.
4. With the switch open, connect the current meter in series and the voltage meter in parallel with one of the resistors. Do not close the switch.
5. When your teacher has approved your circuit, close the switch. Measure the current in and potential difference across the resistor, and record the information in your data table. Open the switch.
6. Rewire the meters to measure the potential difference across and current in the second resistor. Do not close the switch until your teacher has approved your circuit.
7. When your teacher has approved your circuit, close the switch. Measure the current in and potential difference across the resistor, and record the information in your data table. Open the switch.
8. Leave the current meter in place, and carefully rewire the voltage meter to measure the potential difference across the power supply. Record this value in your data table.
9. Clean up your work area. Put equipment away safely.

ANALYSIS:

1. Using your measurements for potential difference and current, compute the resistance values of R_1 and R_2 in each circuit.

2. Compute the equivalent resistance R_{eq} using the values found in item 1.
3. Explain how the combination of resistors affects the total resistance in the circuit.
4. Explain how the combination of resistors affects the total current in the circuit.

CONCLUSIONS:

Compare the total current in the circuit with the current through each resistor. What is the relationship between the current in an individual resistor and the total current through the circuit?

LABWORK 7

TITLE:

Power and work of current

OBJECTIVES:

- Measure current and potential difference across resistor.
- Measure power and work of current

MATERIALS LIST:

1. power source (or battery)
2. stopwatch
3. ammeter
4. voltmeter (or multimeter)
5. connecting wires
6. calorimeter
7. electronic (or mechanical) scales
8. thermometer
9. stirring rod
10. water
11. switch



SAFETY:

1. Never close a circuit until it has been approved by your teacher.
2. Never rewire or adjust any element of a closed circuit.
3. Never work with electricity near water; make sure the floor and all work surfaces are dry.
4. If the pointer on any kind of meter moves off the scale, open the circuit immediately by opening the switch.

5. Do not attempt this exercise with any batteries or electrical devices other than those provided by your teacher for this purpose.
6. Use a hot mitt to handle resistors, light sources, and other equipment that may be hot. Allow all equipment to cool before storing it.
7. If a thermometer breaks, notify the teacher immediately.
8. Do not heat glassware that is broken, chipped, or cracked. Use tongs or a mitt to handle heated glassware and other equipment because it does not always look hot when it is hot. Allow all equipment to cool before storing it.
9. Never put broken glass or ceramics in a regular waste container. Use a dustpan, brush, and heavy gloves to carefully pick up broken pieces and dispose of them in a container specifically provided for this purpose.

THEORY:

- $V = I \times R$
- $P = I^2 \times R = V \times I = V^2 / R$
- $Q = m \times c \times \Delta T$
-

$$V = I \times R$$

$$P = I^2 \times R = V \times I = V^2 / R$$

$$Q = m \times c \times \Delta T$$

- What is Q? What is the unit of measurement of Q?
- What is m? What is the unit of measurement of m?
- What is c? What is the unit of measurement of c?
- What is ΔT ? What is the unit of measurement of ΔT ?

- What is V ? What is the unit of measurement of V ?
- What device does measure V ?
- What is I ? What is the unit of measurement of I ?
- What device does measure I ?
- What is R ? What is the unit of measurement of R ?
- What device does measure R ?
- Why does electric current flow through circuit?
- Why does resistor heat up?

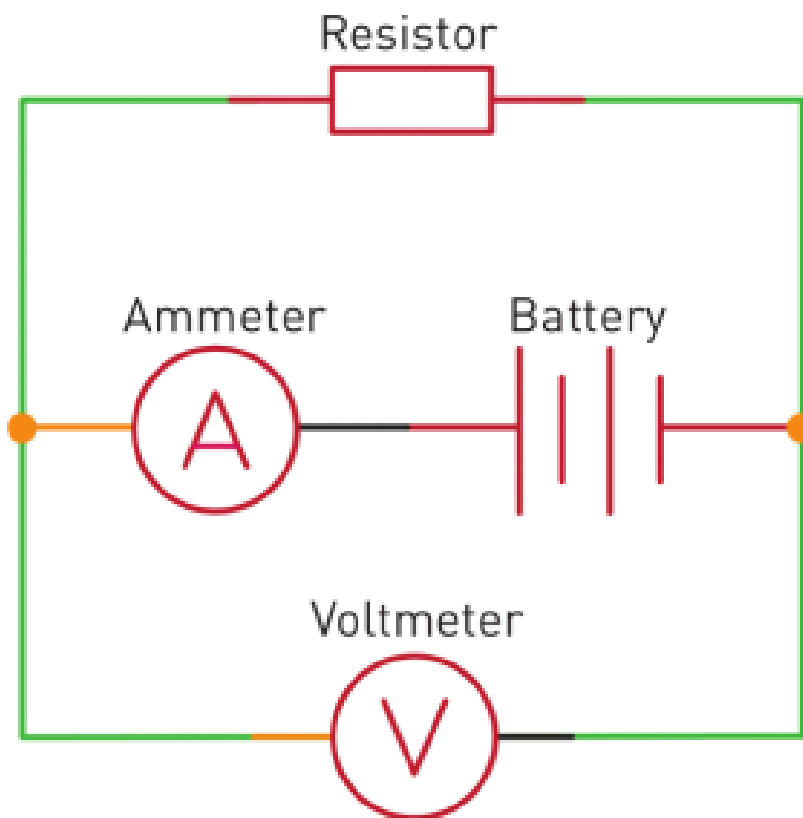

PROCEDURE:

1. Read the entire lab PROCEDURE, and plan the steps YOU WILL take.
2. Record your data in the data table.

3. Measure mass of water, put water in calorimeter, measure temperature of water.
4. Construct a circuit containing a power supply, a switch, and the calorimeter, as shown in Figure. Do not close the switch until your teacher has approved your circuit.
5. With the switch open, connect the current meter in series and the voltage meter in parallel with one resistor. Do not close the switch.
6. When your teacher has approved your circuit, close the switch. Measure the current in and potential difference across the resistor, and record the information in your data table. Wait for about 10 minutes and record your time.
7. Measure final temperature of water.
8. Clean up your work area. Put equipment away safely.

ANALYSIS:

1. Using your measurements for potential difference and current, compute the power released in calorimeter.
2. Calculate work done by electric current.
3. Calculate heat absorbed by water.
4. Calculate efficiency of electric heater.
5. Calculate heat dissipated to surroundings.

CONCLUSIONS:

Why is efficiency not 100%?

SUMMARY

- The potential difference (voltage) of battery “pushes” free electrons through a conductor. The directed motion of charged particles in a circuit is called an electric current.
- $I = q/t$
-

$$I = q/t$$

- A direction of electric current is assumed as from positive terminal to negative terminal.
- Conductors – allow current to pass through them.
- Insulators – do not allow current to pass through them.
- Electric current can exist only in closed loops. These loops are called circuits.
- The potential difference is called voltage.
- We use an ammeter to measure electric current.
- The potential difference is also known as voltage.
- Voltage is measured by a device called a voltmeter.
- Electric current is directed motion of charges in a conductor. Conductors resist the motion of free electrons. This is called electrical resistance.
- Ohm’s law:

- $R = V/I$

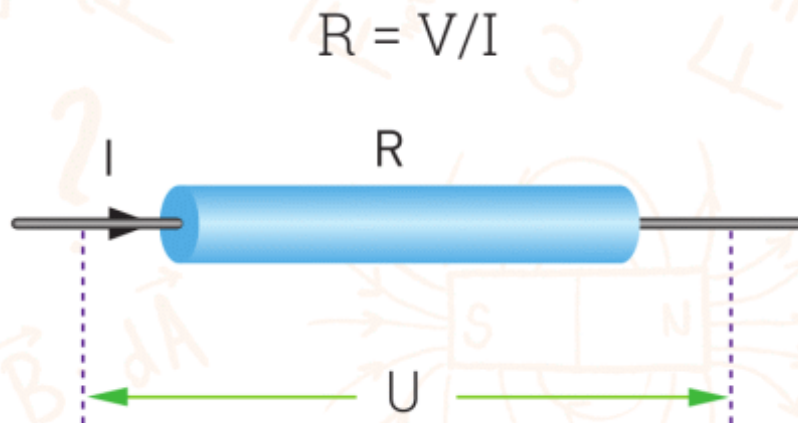

- The resistance of a conductor depends upon three factors: length, cross-sectional area (thickness) and type of material.

$$R = \rho \times \frac{l}{S}$$

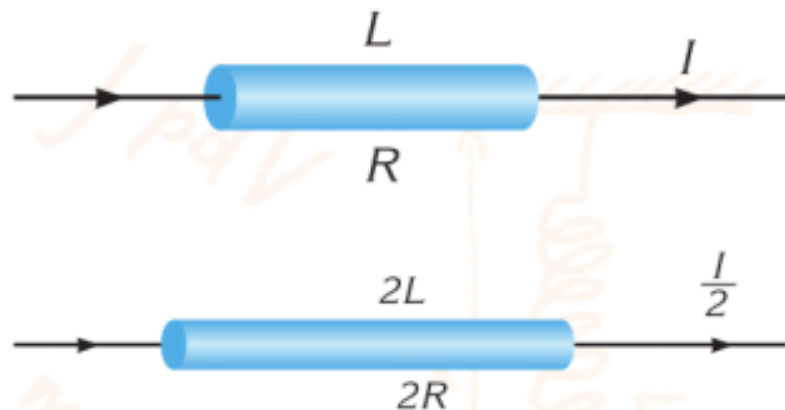

- A rheostat is a variable resistor. It is used to change the current in a circuit.
- There are 2 types of combination of resistors: series and parallel.

- When you connect two or more resistors end to end, it is called a series combination.
- a) $I = I_1 = I_2$
- b) $V_{\text{total}} = V_1 + V_2$
- c) $R_{\text{eq}} = R_1 + R_2$
-

$$\text{a) } I = I_1 = I_2$$

$$\text{b) } V_{\text{total}} = V_1 + V_2$$

$$\text{c) } R_{\text{eq}} = R_1 + R_2$$



- When you connect two or more resistors side by side, it is called a parallel combination.
- a) $V = V_1 = V_2$
- b) $I = I_1 + I_2$
-

$$a) V = V_1 = V_2$$

$$b) I = I_1 + I_2$$

$$c) \frac{1}{R_{eq}} = \frac{1}{R_1} + \frac{1}{R_2}$$

- Electrical Power:

-

$$P = I \times V$$

- $P = I \times V$
- Electrical energy and Joule-Lenz law:
- $E = P \times t$
- $E = I^2 \times R \times t$
-

$$E = P \times t$$
$$E = I^2 \times R \times t$$

- During the short circuit, high current flows through the circuit.
- A fuse consists of a small glass tube with a thin wire inside.

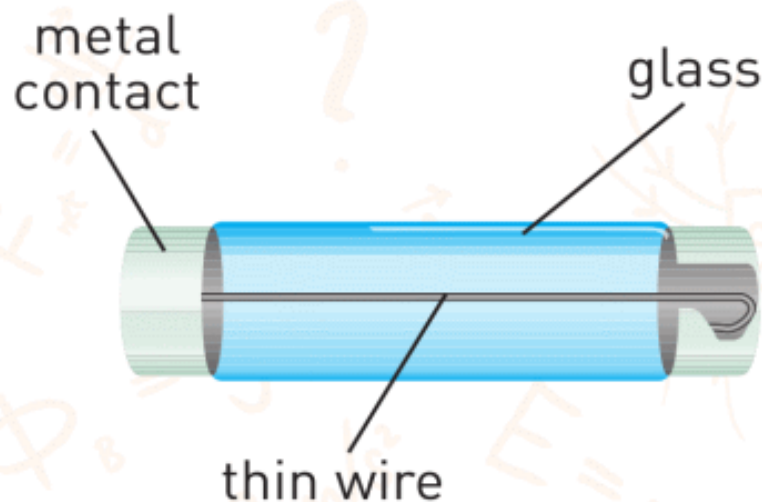

- A circuit breaker (the type of fuse) is similar to a switch. When the current is high it breaks the circuit.
- As the temperature of a wire increases, its resistance increases too.
- Electrolysis is the name of the process used to separate compounds into elements by means of electric current.
- Electroplating is the process of coating the surface of metal objects using electric current.

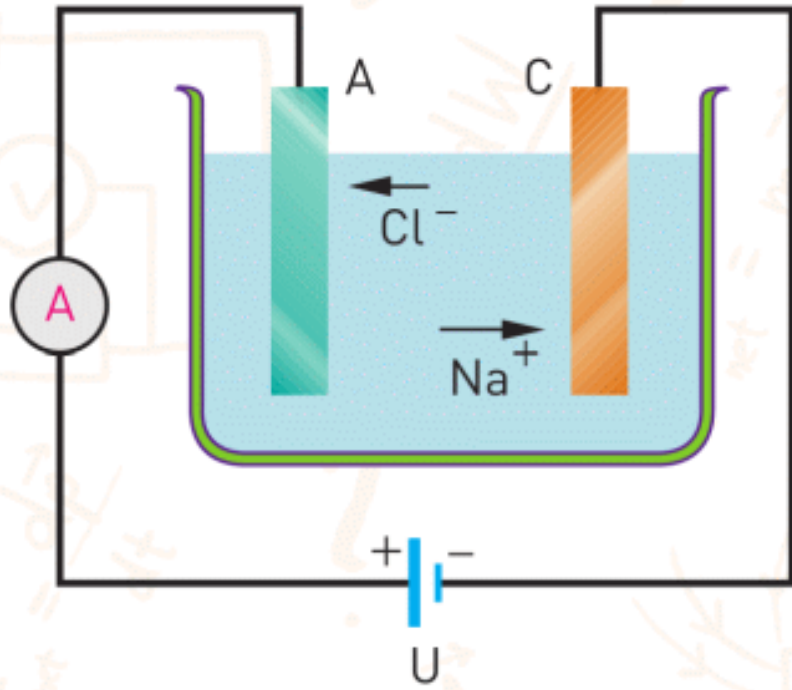

PROBLEMS

ANSWER THE QUESTIONS

1. What is the equivalent resistance between K and M?

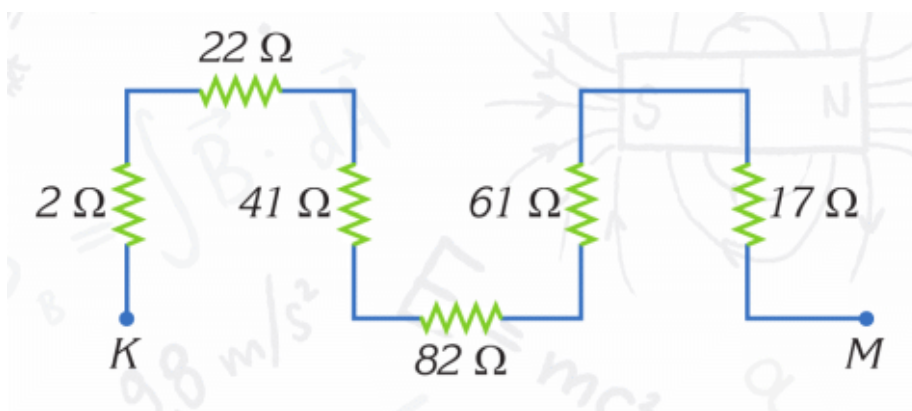

2. Calculate the currents in the circuit.

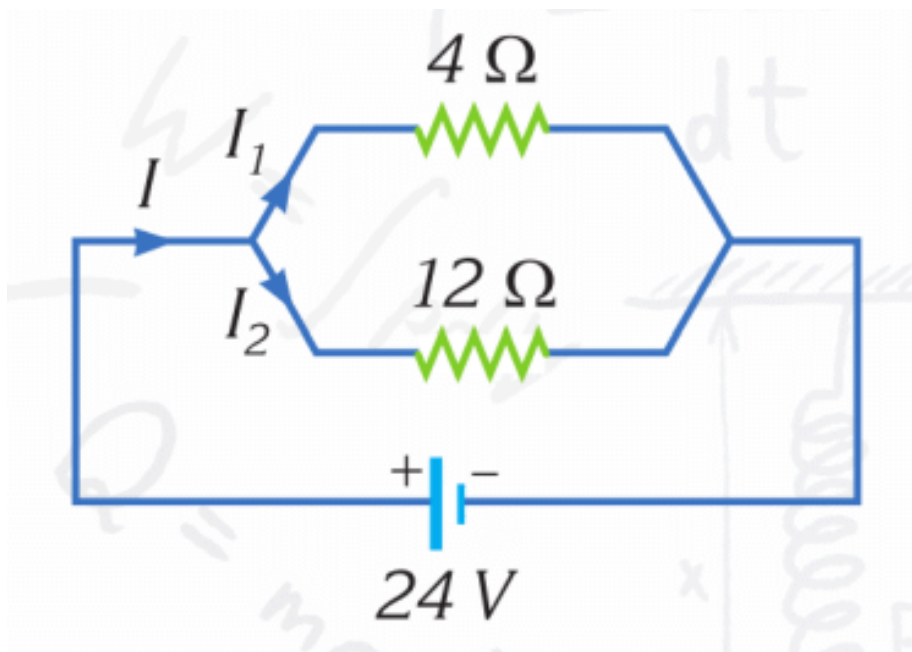

3. What is the resistance R in the circuit?

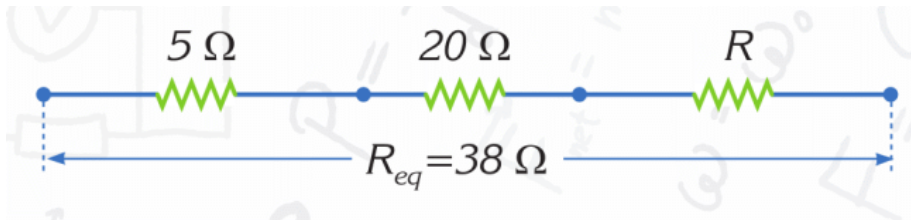

4. A student wants to measure the resistance of a resistor. Which circuit diagram should the student use?

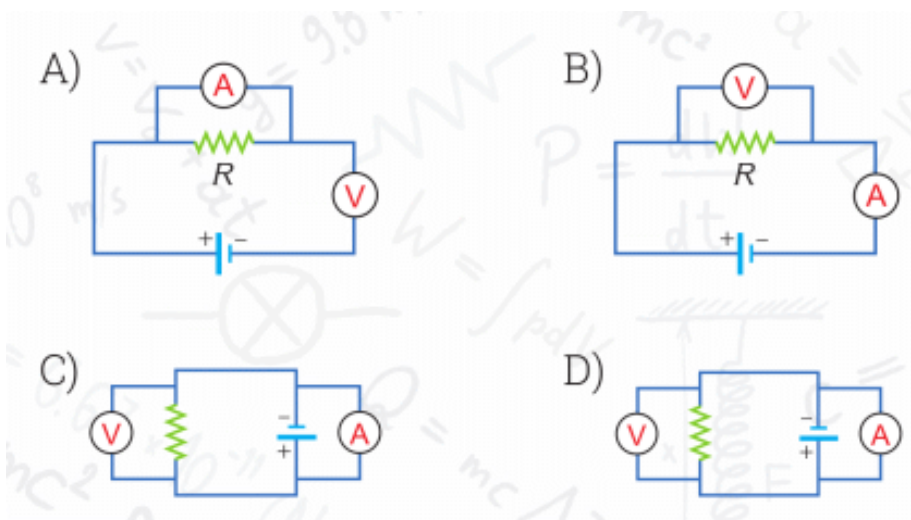

5. What is the current I in the circuit?

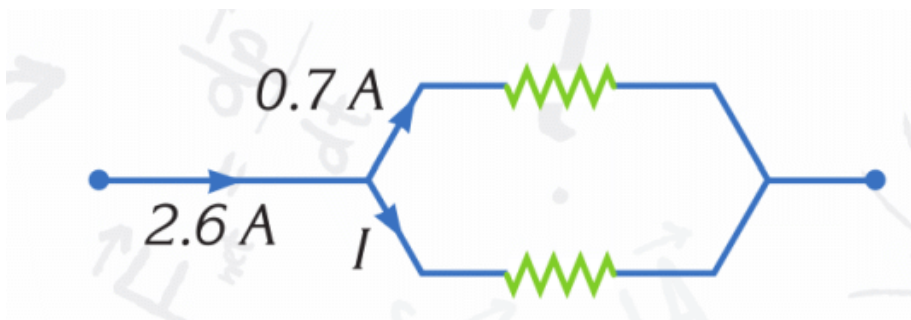

6. What is wrong with the circuit given in the figure?

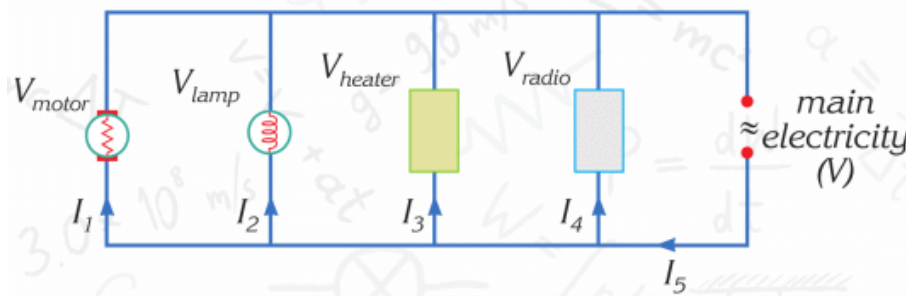

A) $I_1 = I_2 = I_3 = I_4$

B) $V_{\text{motor}} = V_{\text{lamp}} = V_{\text{heater}} = V_{\text{radio}}$

C) I_5 is the largest current

7. 1200 W, 2000 W and 720 W devices will be operated on 220 V at the same time. Calculate the current through each device.

8. A vacuum cleaner of power rating 1440 Watt operates on 240 V. What is the correct current of fuse in the circuit used to operate this machine?

9. The power rating of a kettle is 1200 W. If the kettle draws 5 A, what is the operation voltage of the kettle?

10. If an electrical device dissipates 1800 J in 5 minutes, what is the power of the device?

PHYSICS IN LIFE

1. Fruits and vegetables can produce electricity. How?

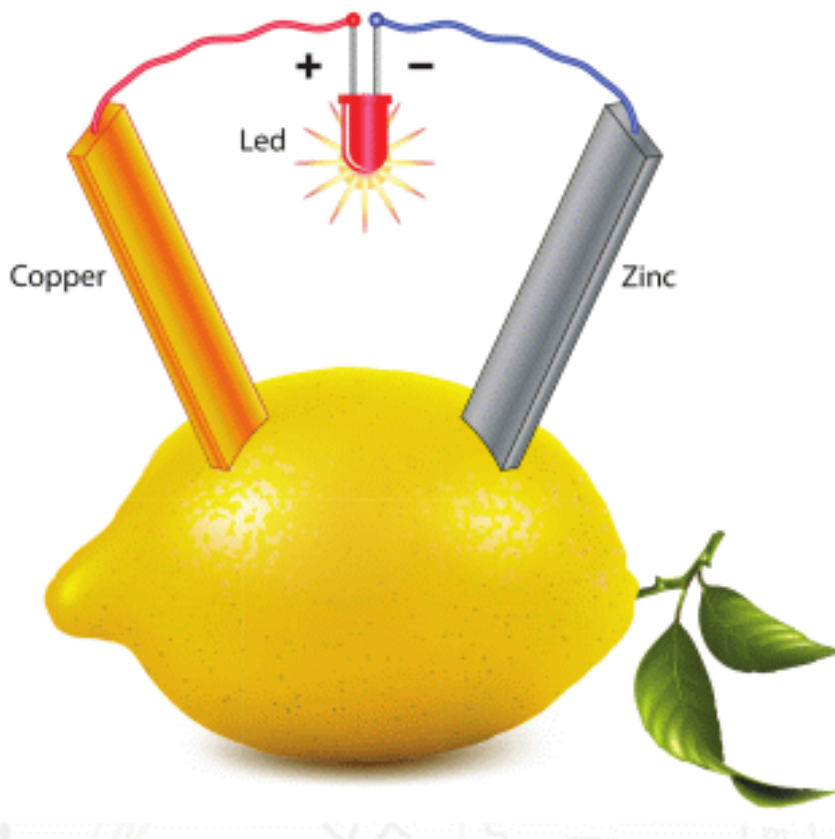

2. The cost of electricity of an average lightning is about 1000000 KZT. Why we do not use it?



3. Handles of these instruments are made of rubber and plastic. Why?



4. Sometimes doctors use this device to give an electric shock through human body. Why?



5. Birds can sit on high-voltage wires. However, electricity does not harm them. Why?

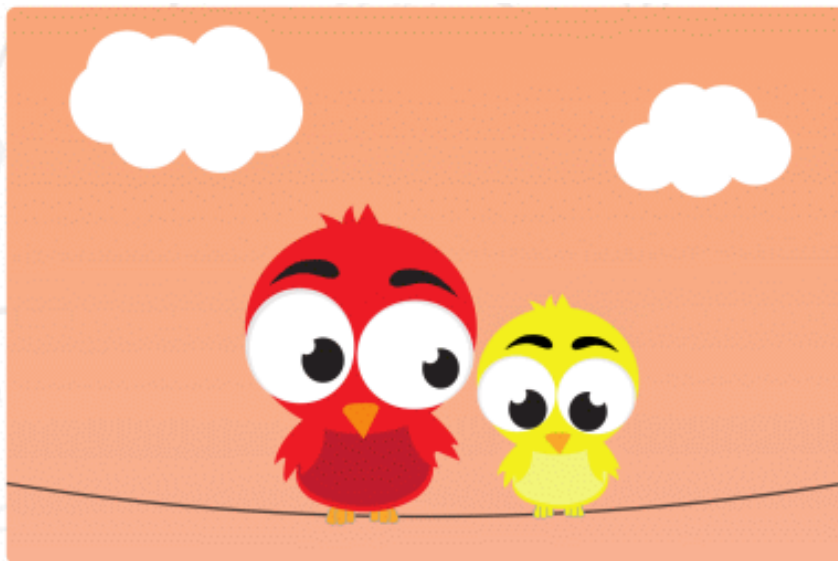

6. People are able to control their muscles. How?

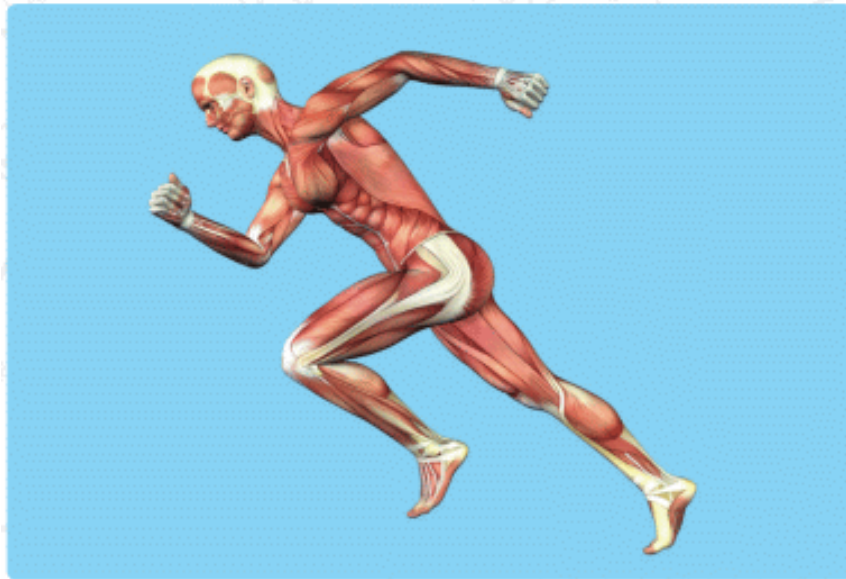

CHAPTER 6

ELECTROMAGNETISM

6.1 MAGNETIC FIELD

6.2 MAGNETIC FIELD IN NATURE

6.3 ELECTRIC MOTORS

6.4 ELECTRICITY PRODUCTION

LAB WORK 8

LAB WORK 9

SUMMARY

PROBLEMS

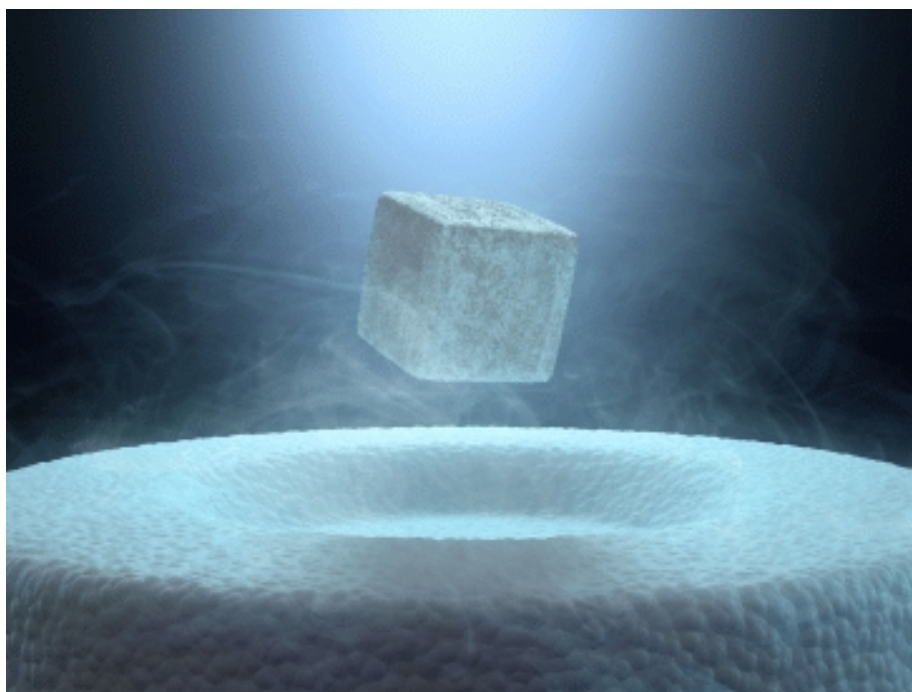

6.1 MAGNETIC FIELD

YOU WILL:

- - explain properties of magnetic field;
- - determine direction of magnetic field of straight wire and solenoid.

QUESTION



Why do magnets push or pull other magnets and iron objects?

Why can't magnets push or pull plastic or wooden objects?

You attach a magnet to the string. Why does it rotate? Then you attach wood to the string instead of the magnet. Will it rotate?

MAGNETIC FIELD

Магниттер магниттік домен бөліктерінен құралады. Магниттік домен – магниттік өрістері бағыттас болған миллиардтаған атомдар тобы. Әр магниттік домен кішкентай магнит тәріздес.

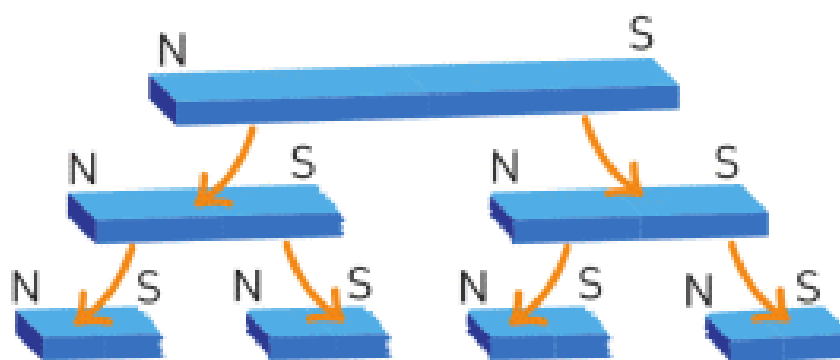

Figure 1

Магниттік қасиеті болмаған заттарда домендердің магниттік өрісі әртүрлі бағытта болады да, жалпы магниттік өріс нөлге тең болады, Figure 2. Сол үшін ағаш, пластик, мыс сияқты заттардың магниттік қасиеті болмайды.

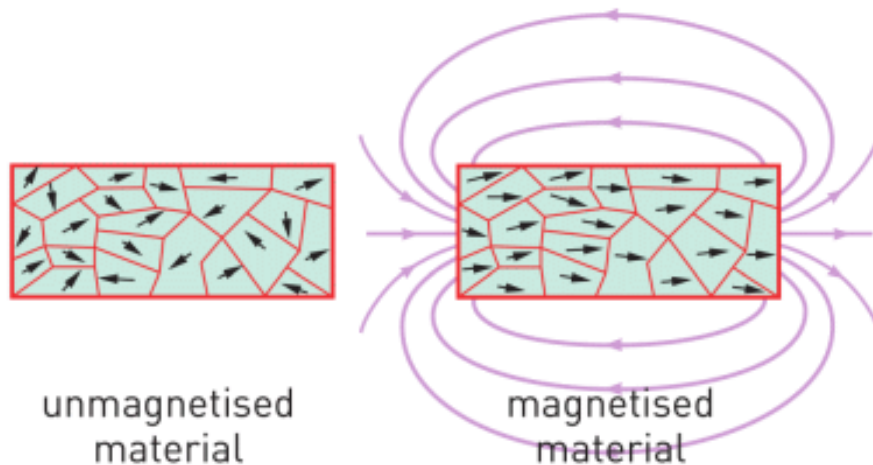

Figure 2

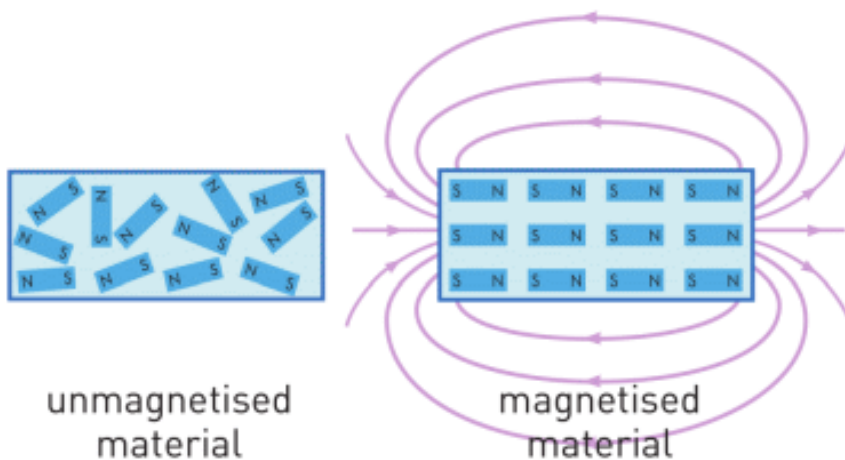

Figure 2

Кез келген магниттың айналасында магнит өрісі пайда болады.

MAGNETIC FIELD LINES

Магниттердің қашықтықта бір бірімен әсерлесуі, осы магнит өрісінің арқасында болады. Тұсбағдардың (компас) ішіндегі кішкентай магнит Жердің магниттік

өрісімен әрекеттесіп айналады да, солтүстік-оңтүстік бағытын көрсетеді.

Магниттің жанына темір ұнтақтарын сепкенде ұнтақтар белгілі сызықтар бойымен орналасады (Figure 3). Бұл сызықтар магнит өрісінің күш сызықтары деп аталады. Магнит өрісінің күш сызықтары тұйық және магнит сыртында, бағыты солтүстіктен (N) оңтүстікке (S) қарай болады.

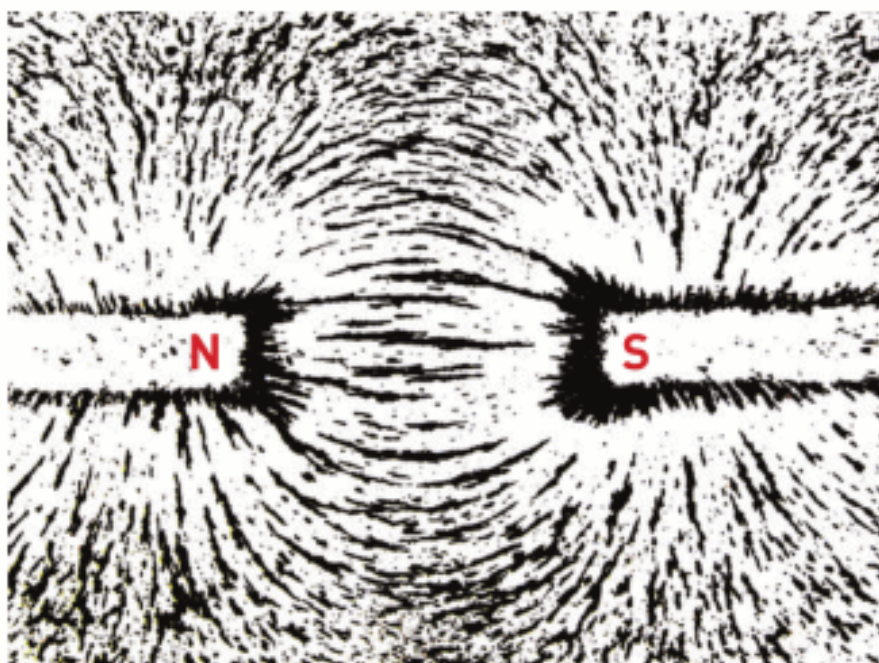

Figure 3

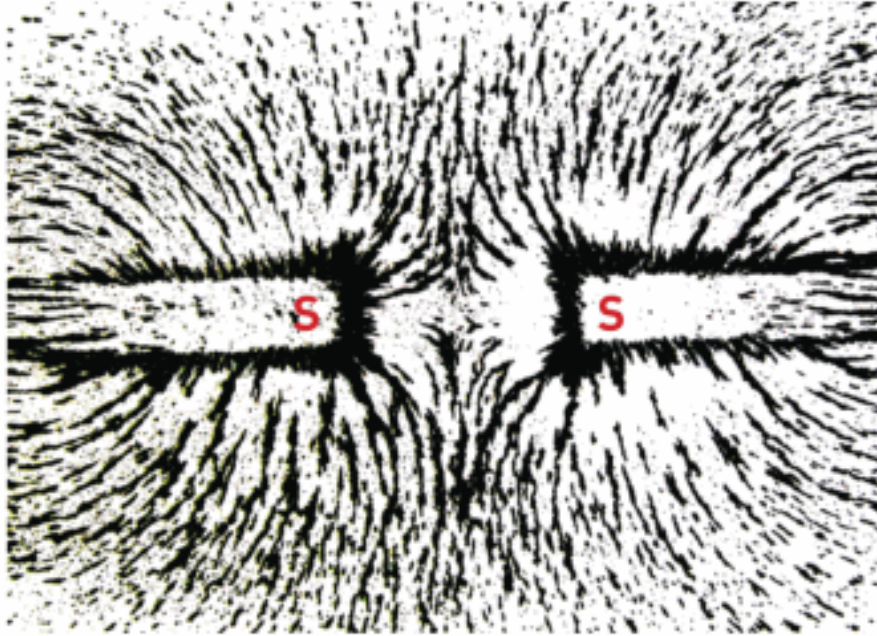
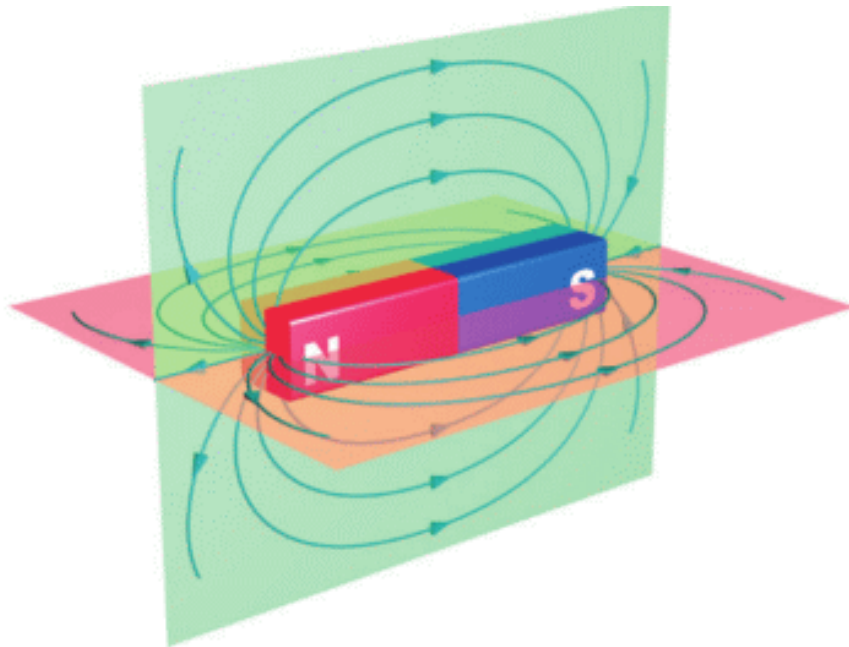
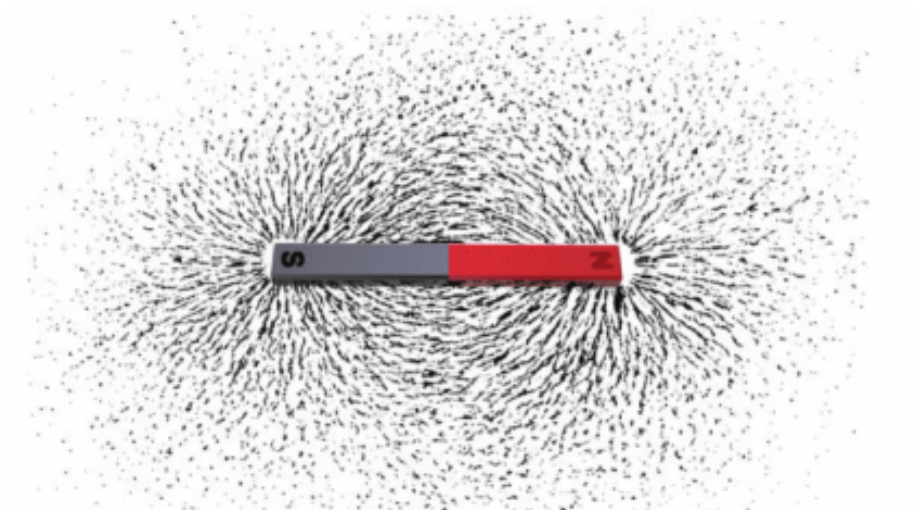

Figure 3

Магниттік өріс сызықтарын көру үшін ұнтақ темір мен магниттік сұйықтық қолданылады (YouTube-та magnetic fluid-ті қарастырыңыз).





ELECTRIC CURRENT AND MAGNETIC FIELD

Кез келген электр тогы бар өткізгіш айналасында магниттік өріс пайда болады. Figure 4 - те ток көзіне қосылған түзу сым көрсетілген.

Iron filings and compass show direction of magnetic field lines, Figure 4 a. You can find direction of magnetic field lines by Right-Hand rule (R.H.R.), Figure 4 c.

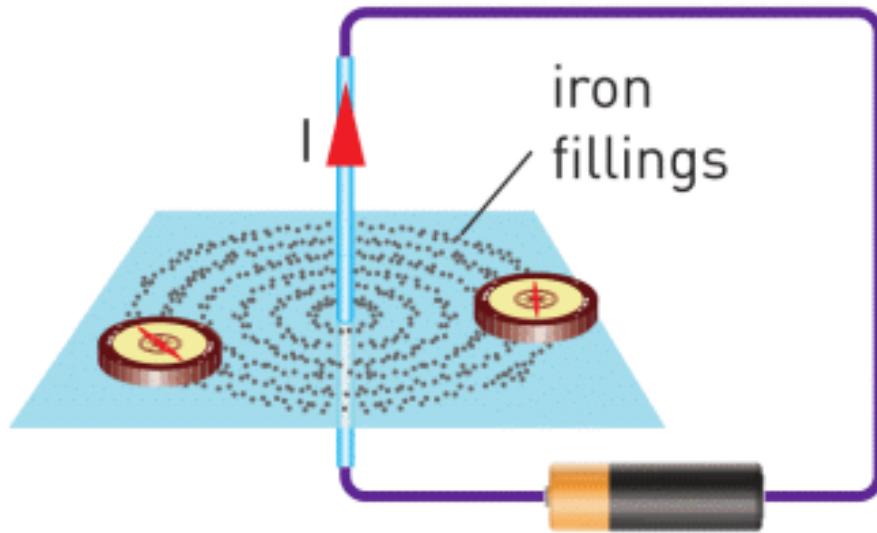

a

Figure 4.

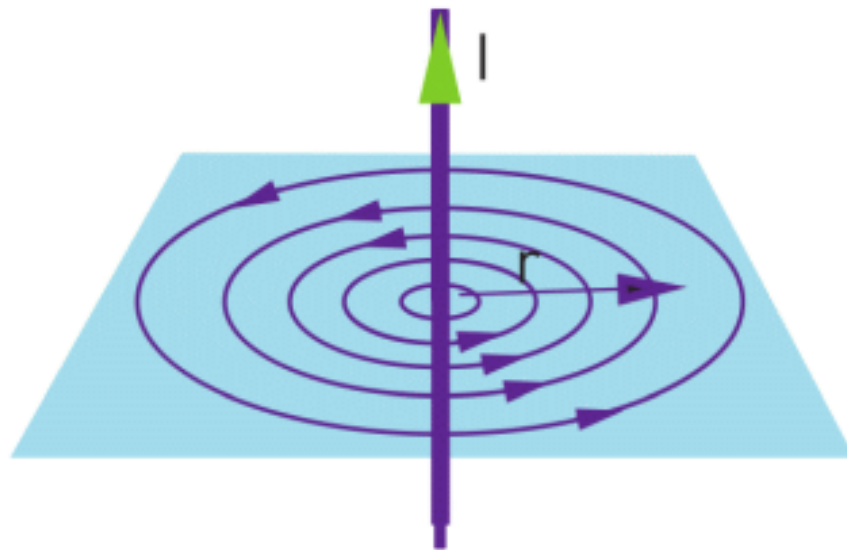

b

Figure 4.

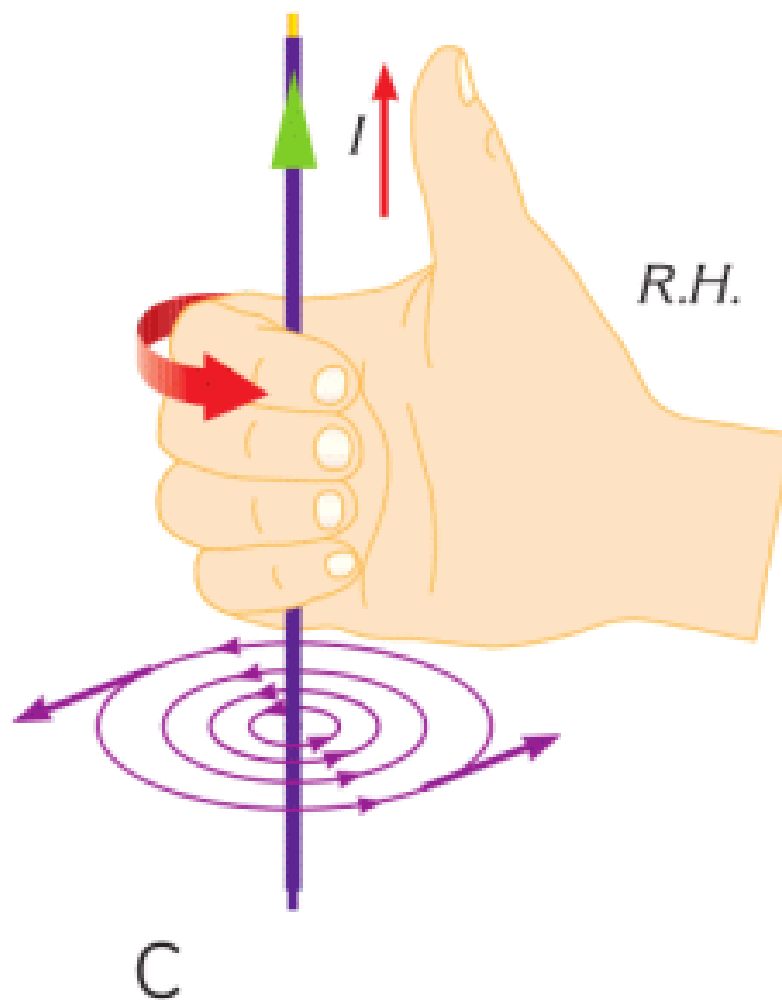
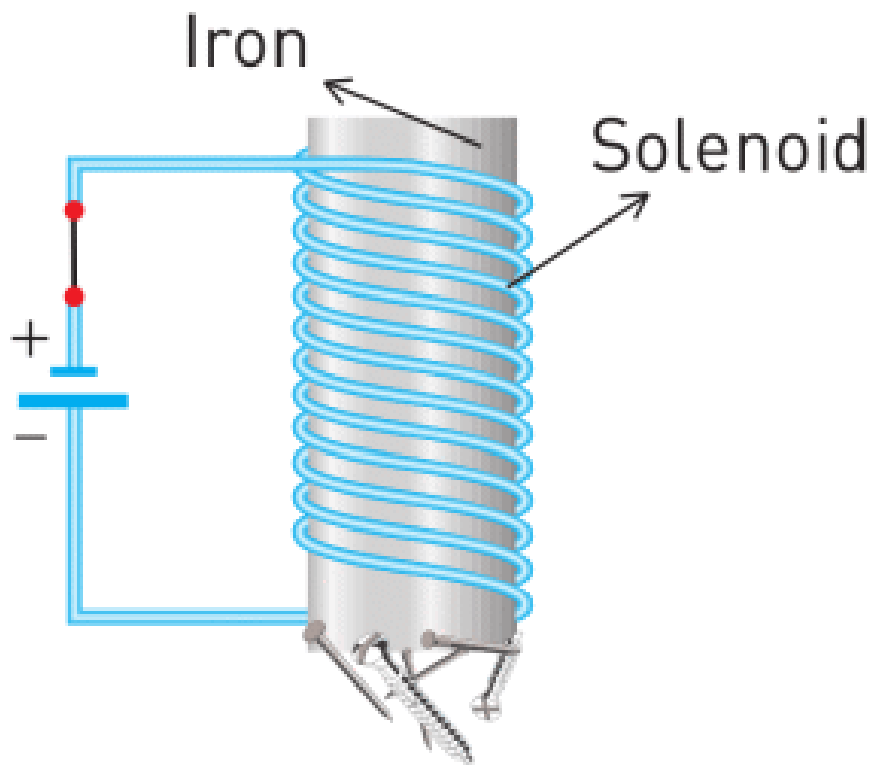

Figure 4.

ELECTROMAGNET

We can construct an artificial magnet using electric current. In Figure 5 a you can see parts of the electromagnet: coil

(solenoid) and iron inside of it. The magnetic field lines of the electromagnet are shown in the Figure 5 b.



a) Working electromagnet
Figure 5.

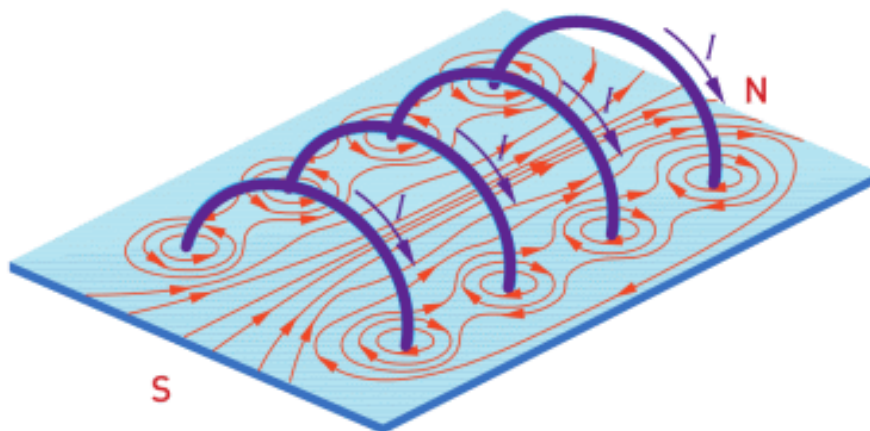

b) Magnetic field in solenoid
Figure 5.

You can find the direction of the magnetic field lines using Right-Hand rule (R.H.R.). Four fingers show the direction of the current and thumb shows the direction of the magnetic field.

ACTIVITY

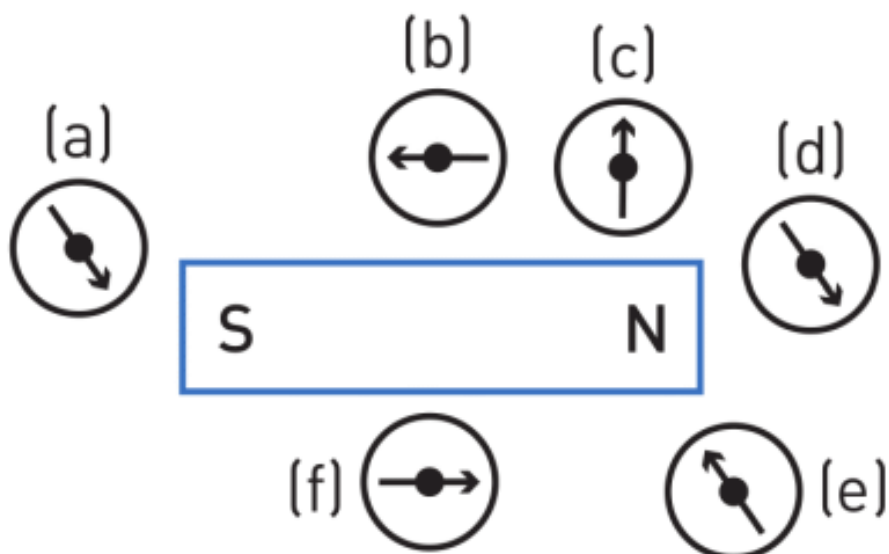

Which of the compass-needles do correctly show the magnetic field lines? Head of the arrow is North. A tail of the arrow is South.

RESEARCH TIME

Materials: a wire with insulation, a nail, battery (1.5 Volts or 9 Volts), small iron objects.

Procedure: Make a setup the same as shown on the figure. Why do iron objects stick to the nail?

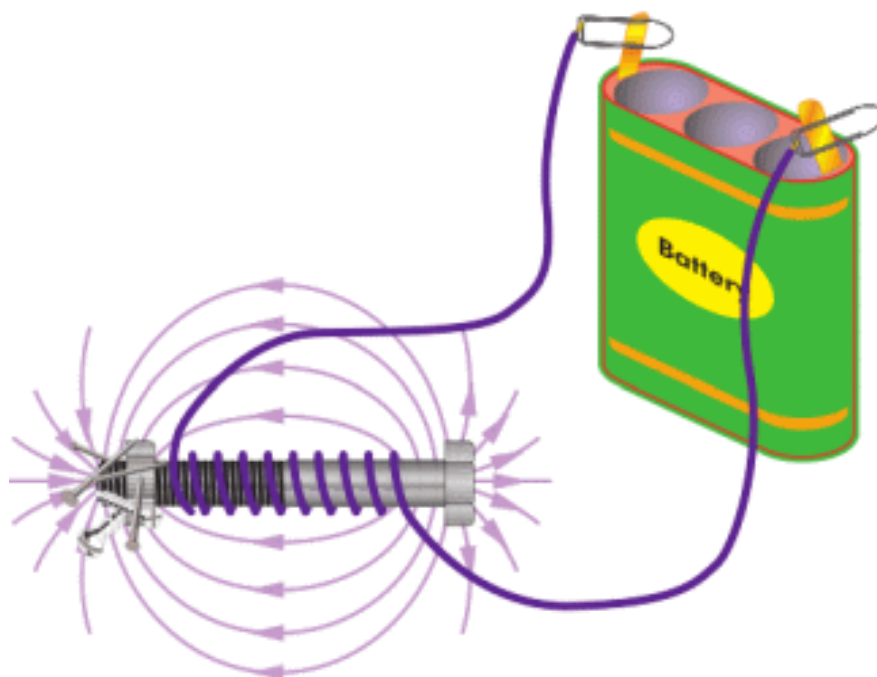

What happens if you add more turns of wire?

What happens if you disconnect the wire from the battery?

FACT

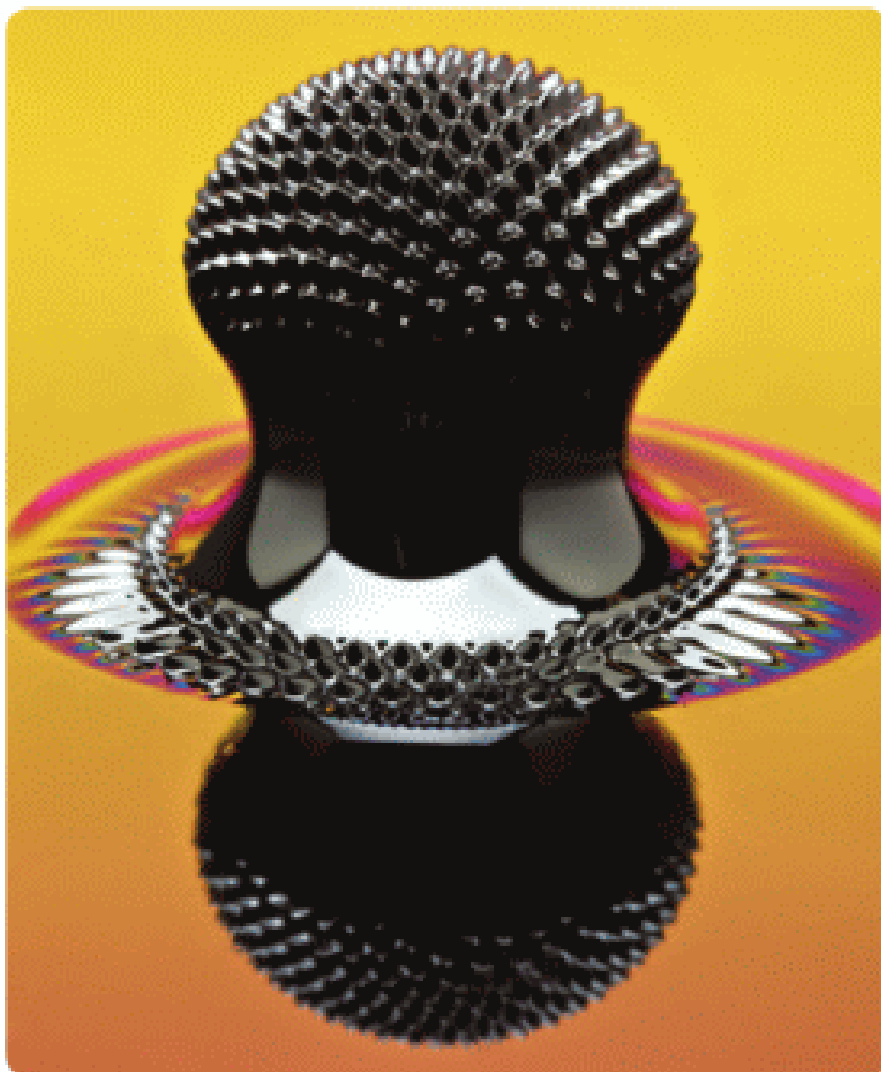

Magnetic fluid (ferrofluid) is used in Hard Disk Drives (HDD), loudspeakers and cancer treatment.

LITERACY

1. Why do magnets push or pull at a distance? Why can you not push or pull any object at a distance?
2. Why are some materials magnetic and other materials are not?

3. When you heat a magnet, it loses its magnetic property. Why do you think this happens?
4. Why does the Earth have the magnetic field? How do animals and people use the magnetic field of the Earth?
5. Why does atom have the magnetic field?
6. What may happen if the Earth has no magnetic field?

ART TIME

Can you make a “magnetic fluid” or “magnetic putty”? What materials can you use? Search “magnetic fluid” or “magnetic putty” on YouTube. Make the “magnetic fluid” or “magnetic putty” and show to parents, teachers, and friends.

TERMINOLOGY

iron – темір / железо

magnetic field – магнітнік өріс / магнитное поле

compass – компас / компас

electromagnet – електромагніт / электромагнит

6.2 MAGNETIC FIELD IN NATURE

YOU WILL:

- - describe magnetic phenomena in nature.

QUESTION



Birds travel long distances, but they do not use any compass and technology. How do birds and some other animals navigate?

MAGNETIC FIELD IN NATURE

Магнит өрісінің табиғаттағы рөлі өте маңызды.

Жіпке ілінген магниттер бұрылып солтүстік пен оңтүстікті жалғайтын сызық бойымен орналасады. Бұл – Жердің

магниттік өрісінің бар болғанына дәлел. Яғни Жер – үлкен магнит. Жер ядросында балқыған металдар қозғалып жатады. Сол балқыған металдардың қозғалысы электр тогын, ал электр тогы магниттік өрісті тудырады деген болжам бар.

Жердің магниттік полюстері мен географиялық полюстері әртүрлі нүктелерде орналасқан. Араларындағы бұрыш шамамен 10° айналасында. Бұл бұрыш әрдайым өзгеруде. Жердің магниттік өріс сызықтарының бағыты экватор жақта жерге параллель, ал полюстерде жерге перпендикуляр (Figure 1).

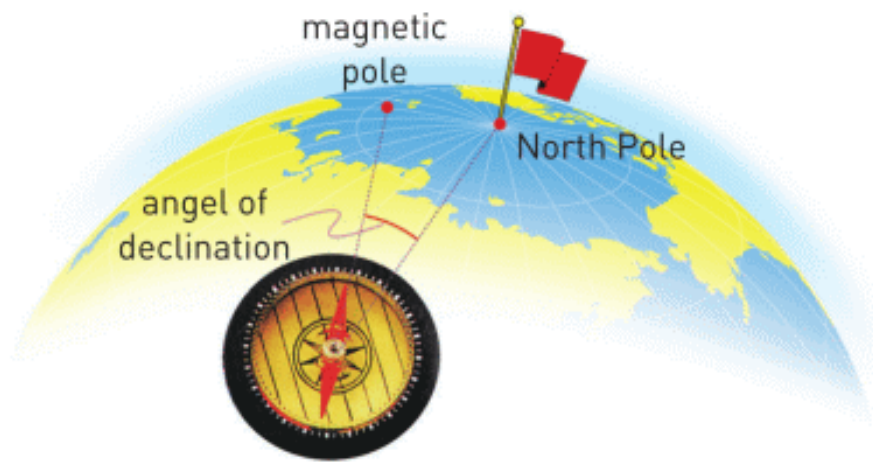

Figure 1

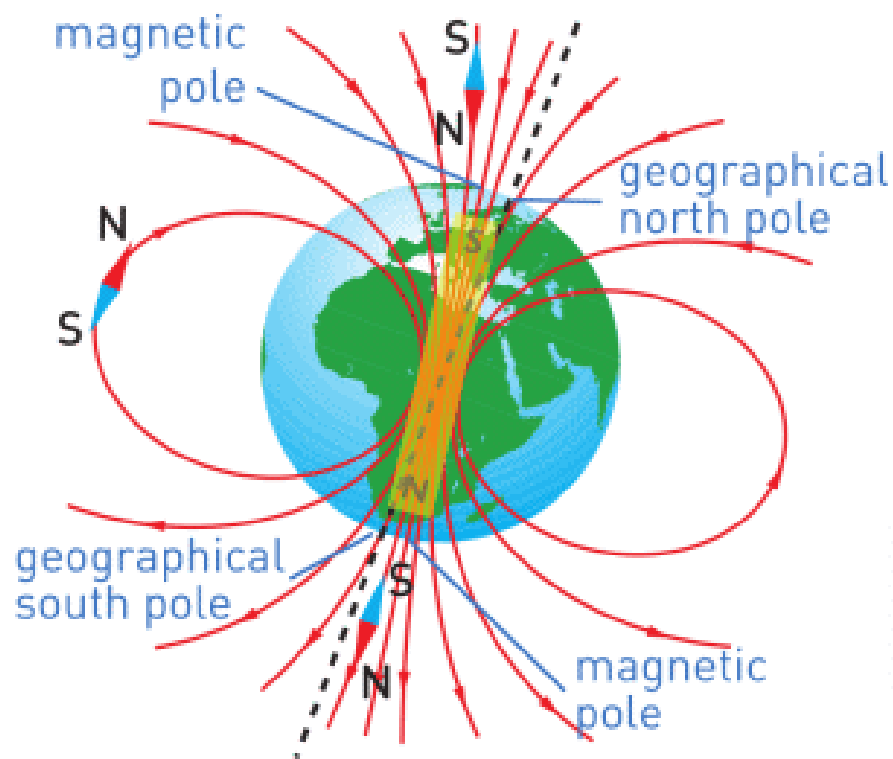
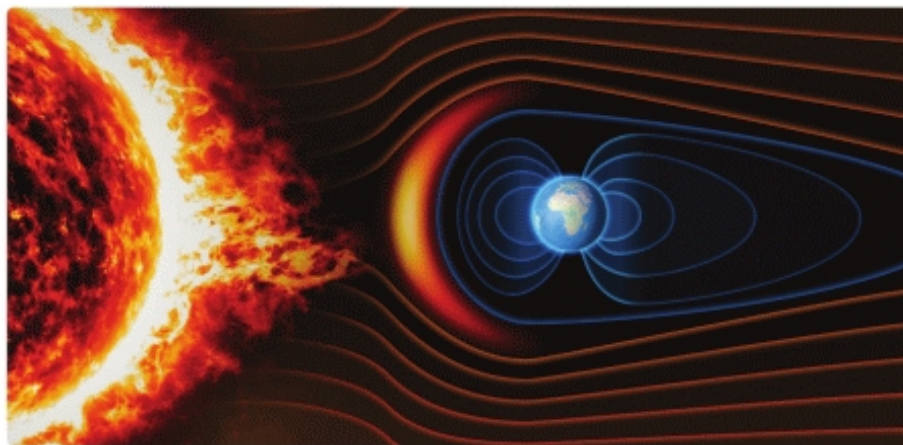

Figure 1

Жердің магниттік өрісінің әсері (магнетосфера) 70000-80000 км қашықтыққа дейін сезіледі.



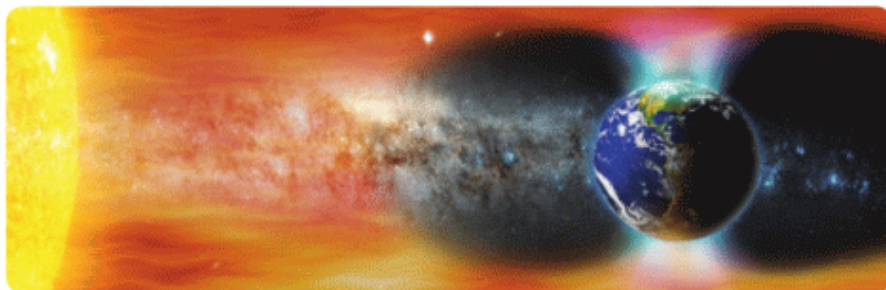

Figure 2



Figure 3

Магнетосфера – Жер планетасын Күннен шыққан зиянды ғарыш сәулелерінен қорғайтын қалқан. Магнетосфера болмаса, ғарыштық сәулелер әсерінен тірі ағзаларда ісік және рак пайда болатын еді.

Яғни, магнетосфера болмаса, ғарыштық сәулелер Жердегі барлық тіршілікті жойып жіберетін еді.

BIRDS

The results of the research indicate that birds use the Earth's magnetic field to determine their direction of flight, Figure 4. The presence of the magnets placed on their heads destroyed the orientation of magnetite particles naturally inside the bird's own head so that they could not sense the Earth's magnetic field.



Figure 4

Magnetite particles have also been found in other living things such as bacteria, monarch butterflies, tuna fish, dolphins, and whales.

MAGNETOSTATIC BACTERIA

Some types of bacteria living in the water around the magnetic poles of the Earth find their direction of motion by using the Earth's magnetic field. For this reason, these bacteria are called magnetostatic bacteria.

They have intracellular chains of magnetite particles in their bodies as shown in Figure 5. The iron oxide particles in the chain act as tiny magnets and help bacteria to determine the downward direction. Thus they can move down to nutrient-rich sediments or stay in optimal depths in water. Remember that at the magnetic poles magnetic field lines extend down towards the Earth's core.

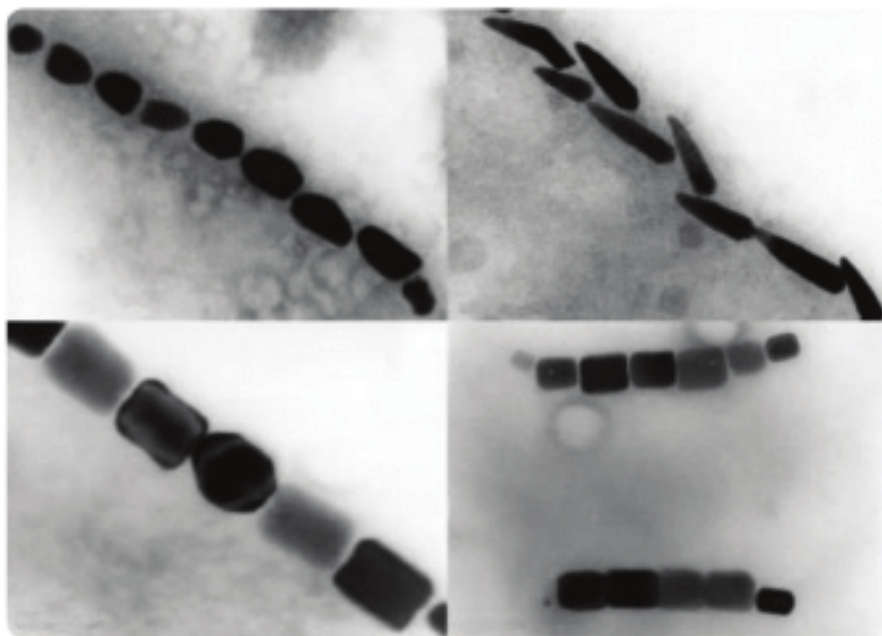
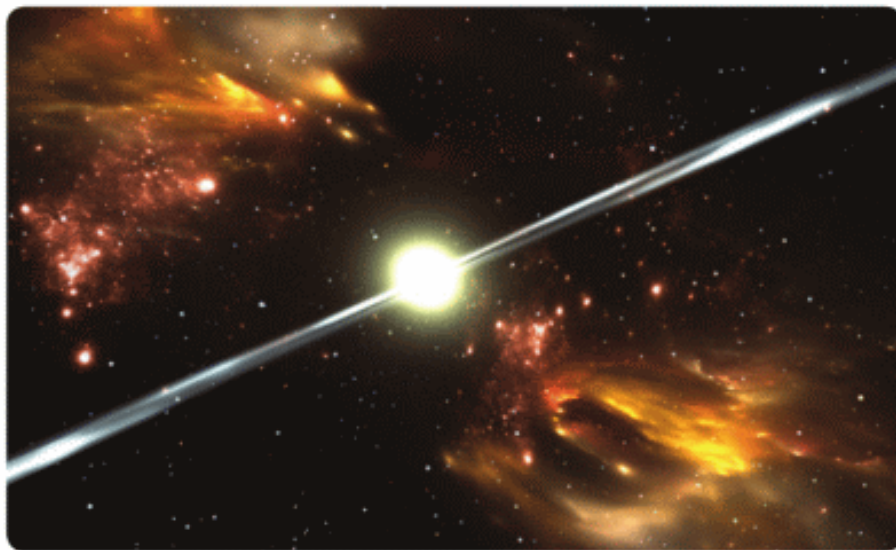

Figure 5

FACT



The greatest magnets in the Universe are neutron stars. Their magnetic field could be 10^{15} stronger than Earth's.

IT-LINK

Download smartphone or tablet application – compass.

RESEARCH TIME

Materials: water, plate, needle, magnet, tape, styrofoam or cork.

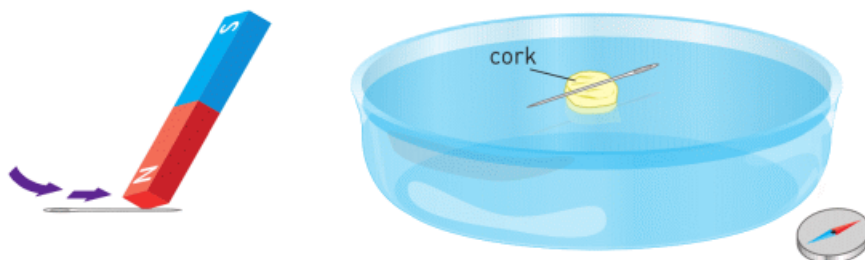

Procedure: Rub the needle with the magnet many times. Tape the needle to styrofoam and put them on the water. In which direction does the needlepoint? Why does it show that direction?

LITERACY

1. What is the role of magnetic field in nature?
2. What is magnetosphere and how does it protect us?
3. Are magnetic North and geographical North the same places?
4. Give examples of how animals and people use the magnetic field to navigate.

ART TIME

Hide a treasure (important thing) anywhere and mark it on map. Show coordinates to your classmates. Use a compass or smartphone application to find classmate's treasures.

TERMINOLOGY

hazardous – қауіпті / опасный

cosmic rays – ғарыштық сәулелер / космические лучи

hemisphere – жарты шар / полушарие

to navigate -бағдар алу / ориентироваться

6.3 ELECTRIC MOTORS

YOU WILL:

- - describe the effect of the magnetic field on current carrying wire;
- - explain the structure and working principles of an electromotor and electric devices.

QUESTION



Why do these tools need electricity to work? Why can't they work without it?

ELECTRIC MOTORS

Сым арқылы ток өткен кезде сыртқы магнит өрісі сымды қозғалысқа келтіре алады. Күштің бағыты сым ішіндегі

тоқтың бағытына байланысты, Figure 1 a,b. Ток күші болмаса, күш әсер етпейді, Figure 1 c. Бұл күш магниттік күш деп аталады.

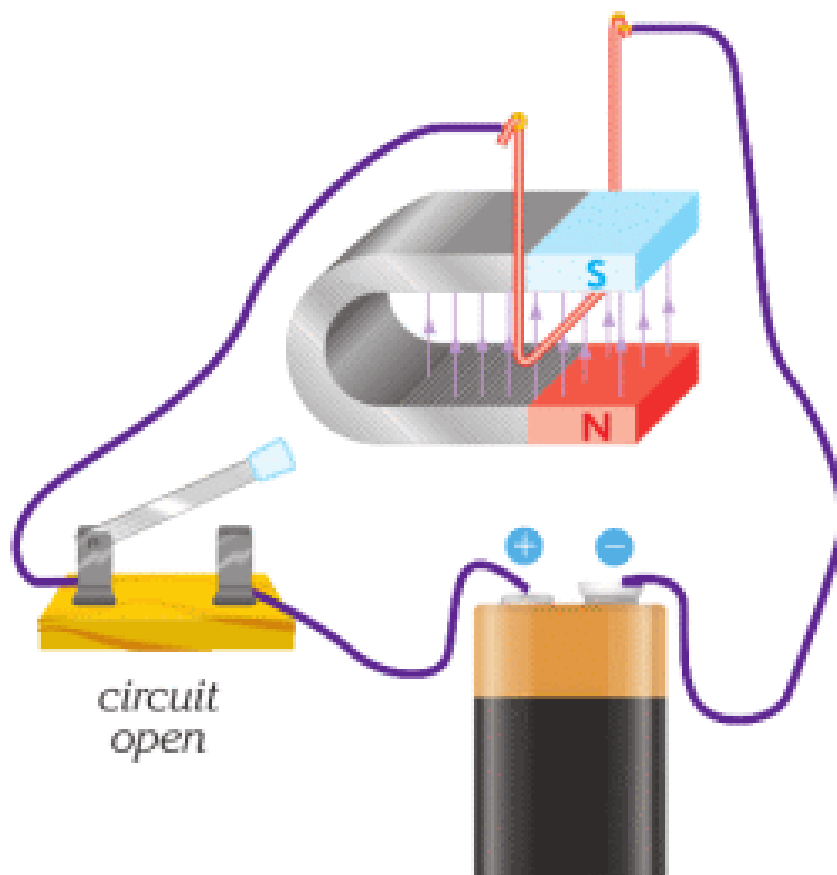

a

Figure 1

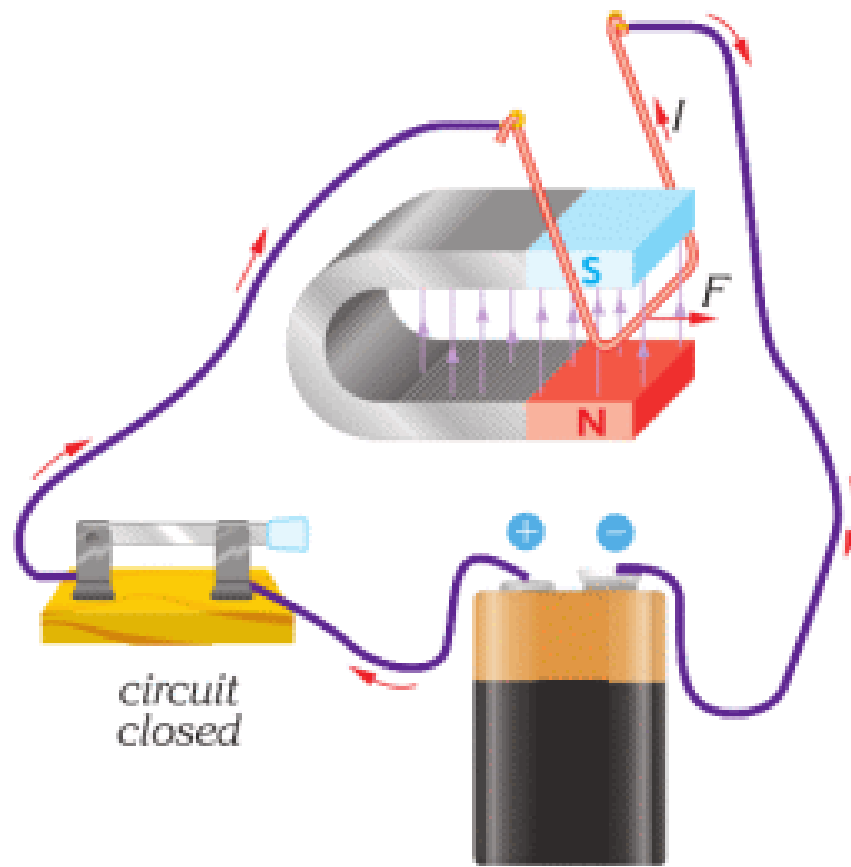

b

Figure 1

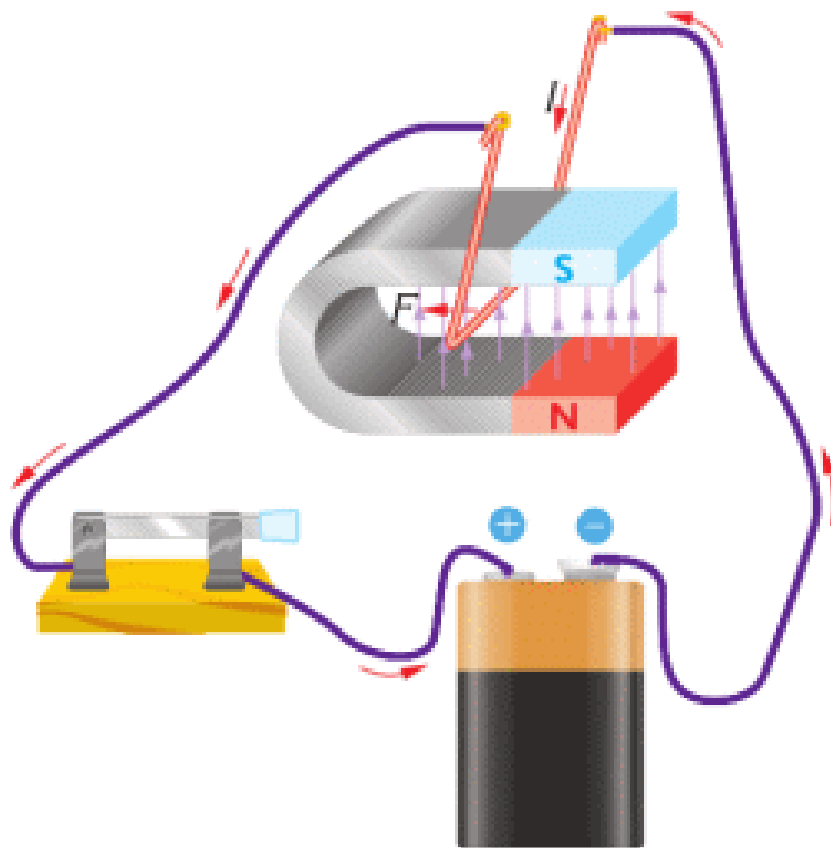

C

Figure 1

Магнит өрісінде тогы бар сымға магниттік күштің әсері техникада кеңінен пайдаланылады. Мысалы, қозғалтқыш электр энергиясын механикалық энергияға айналдырады. Электр қозғалтқышының сұлбасы Figure 2 а - да берілген. Қозғалтқыштың магниті және катушкасы бар, Figure 2 b. Қозғалтқыш арқылы ток өткен кезде магниттер тогы бар катушканы айналдырады.

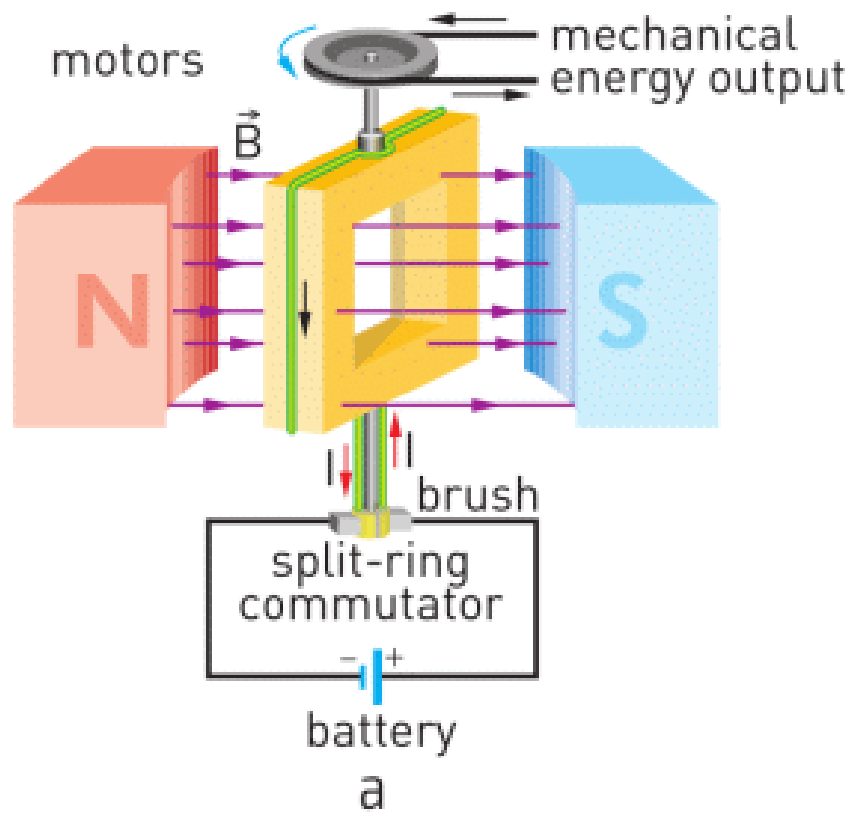
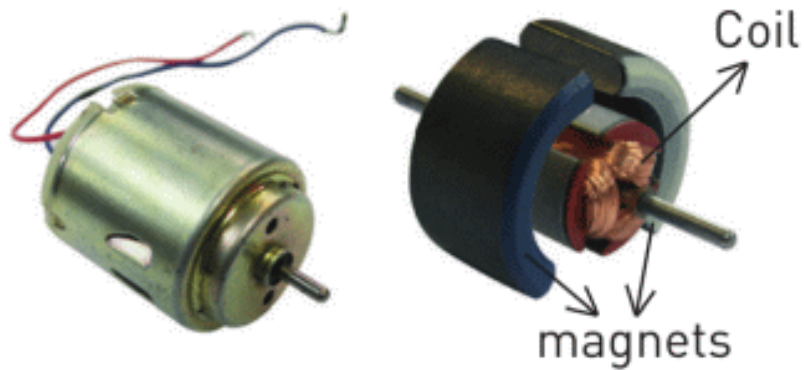

Figure 2



b

Figure 2

Where can we use the motor in the daily life?

FACT



MagLev (magnetic levitation) trains use a magnetic field to float above the ground. When they move they do not touch the ground.

RESEARCH TIME

Electric motor

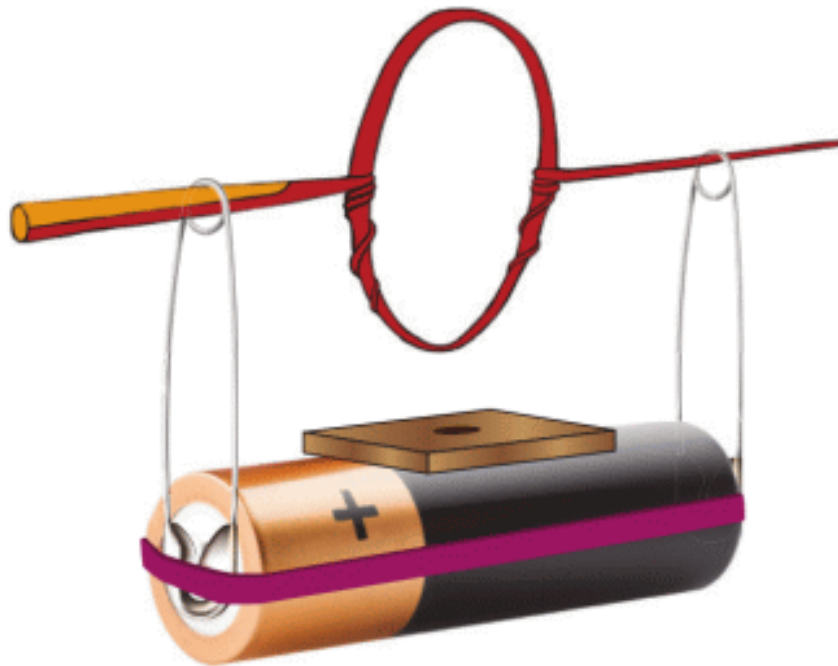

Materials: magnet, battery, safety pin, insulated copper wire, scissors, cutter, rubber band.

Procedure: Use Youtube.com. Search “Simple electric motor”.

FACT

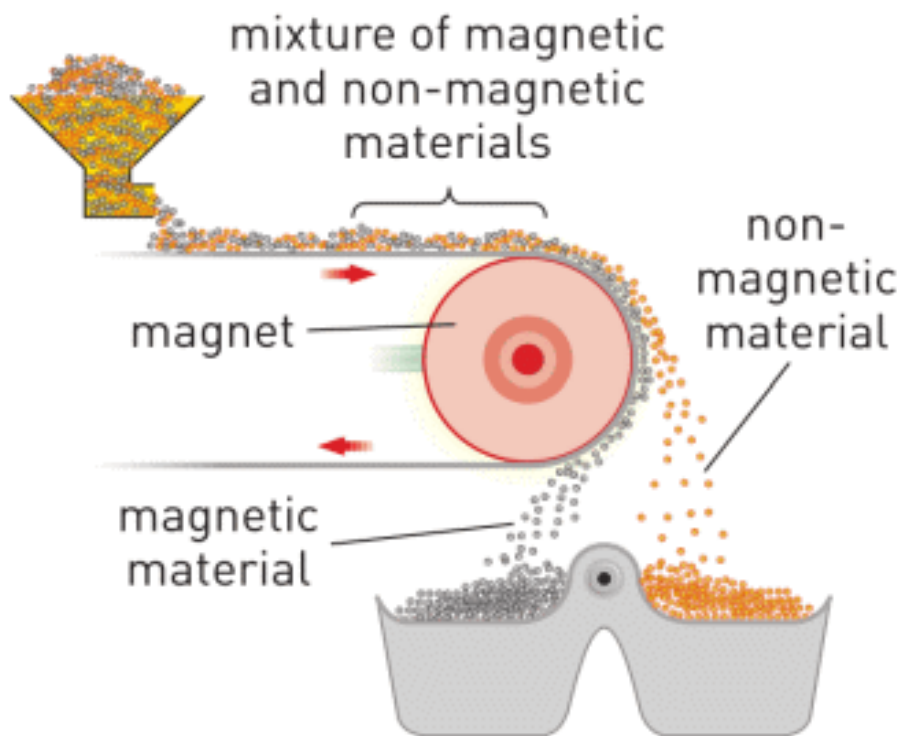

Permanent magnets are used to separate magnetic materials from nonmagnetic ones. The figure below shows how a magnet can separate magnetic materials such as iron pieces from a mixture.

ACTIVITY

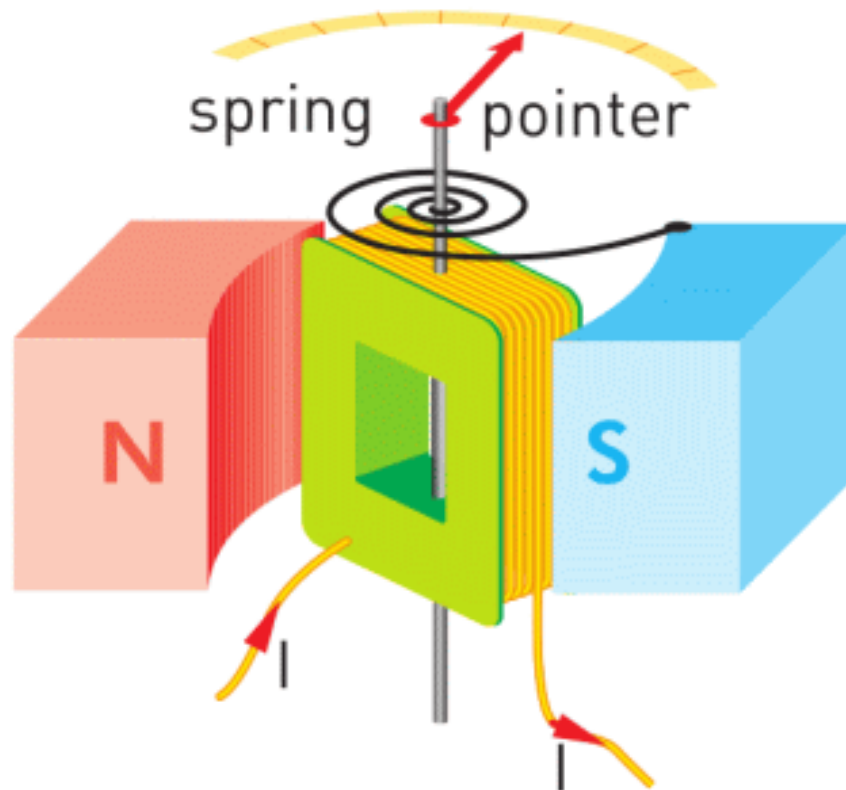

We can use magnetic force in other devices, for example, in ammeters and voltmeters. The model of these tools is shown on the figure. How do you think these devices work? Can you explain the functions of all parts? Discuss your answers.

ACTIVITY

Design a toy

You need to design and draw a toy that can move and do certain functions. You choose the mass, functions, operating current, number of batteries, and number of motors in your toy.

Instructions:

- - The motor works with a current no more than 1.5 A.

- - Each battery can produce current no more than 0.75 A. It means 2 batteries can produce maximum 1.5 A.
- - The motor produces a force. Formula: Force [N] = 4 × Current [A] - 6 N of motor force can push no more than 300 grams of toy's mass.
- - One battery has a charge of 3 Ah.
- - Mass of 1 battery is 30 grams.
- - Mass of 1 motor is 50 grams.

Tasks:

- a) Draw a picture of your toy. How big is your toy? What is the mass of your toy without motors and batteries?
- b) What is your toy's function? What is the operating current? How much force does it need?
- c) How many batteries does your toy need? What is the total mass of your toy?
- d) How much money do you spend on batteries?
- e) You need to calculate how much time your toy can work.

Use this formula

$$\text{Time [h]} = \text{Number of batteries} \times \frac{\text{Total Charge of batteries [Ah]}}{\text{Total operating current [A]}} - 3 \times \text{Total operating current [A]}$$

ART TIME

Can you make a "Curie pendulum"? How does it work? Make it and show it to parents, teachers, and friends.

LITERACY

An electric motor of a lift can lift a maximum mass of 1000 kg. What can you do to make motor lift more?

Why do electric motors use magnets? Why do electric motors use electric current?

Loudspeakers, headphones, and other sound devices need magnet. Why?

Why are “MagLev” trains faster than normal trains?

What can happen if all electromotors on the Earth stop for one hour?

TERMINOLOGY

external - сыртқы / внешний

electric motor - электр мотор / электрический двигатель

mechanical energy - механикалық энергия / механическая энергия

6.4 ELECTRICITY PRODUCTION

YOU WILL:

- - describe electromagnetic induction;
- - give examples of electricity production in the world and in Kazakhstan.

QUESTION

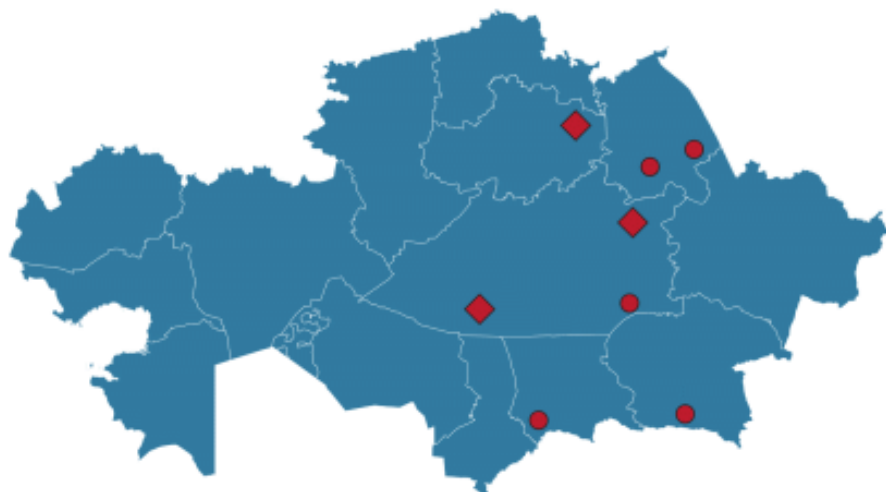

Why does Kazakhstan produce electric energy mostly from the fossil fuel? How would you explain the general process of electricity production?

ELECTRICITY PRODUCTION

Figure 1 а-ға қараңыз. Бұл жерде сым және амперметр көрсетілген. Ешқандай батарея жоқ, сондықтан

амперметр тізбекте ток күшін болмағанын көрсетіп тұр.

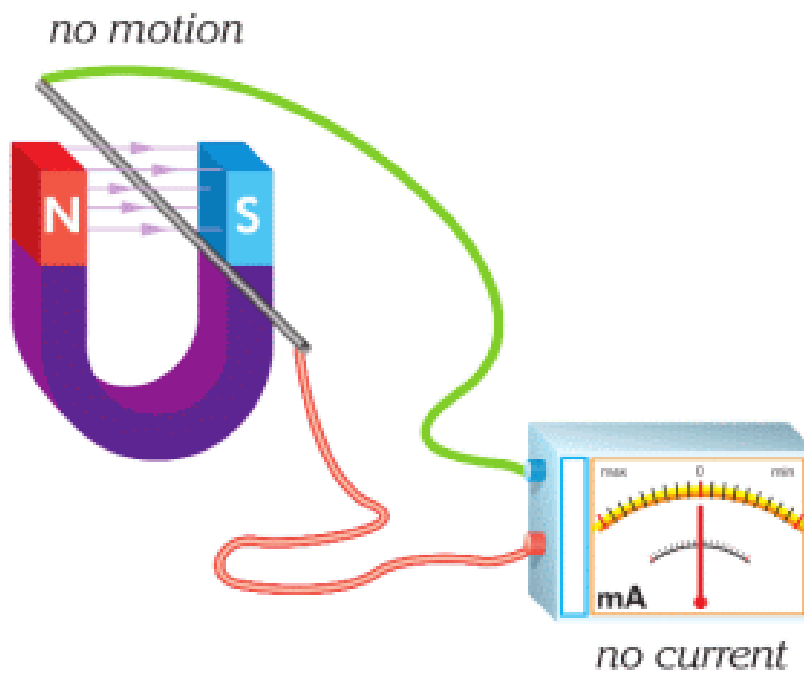

a

Figure 1

Алайда сымды жоғары қимылдатсақ, амперметрдің қимылынан, тізбекте бір уақытта токтың пайда болғанын анықтай аламыз, Figure 1 b.

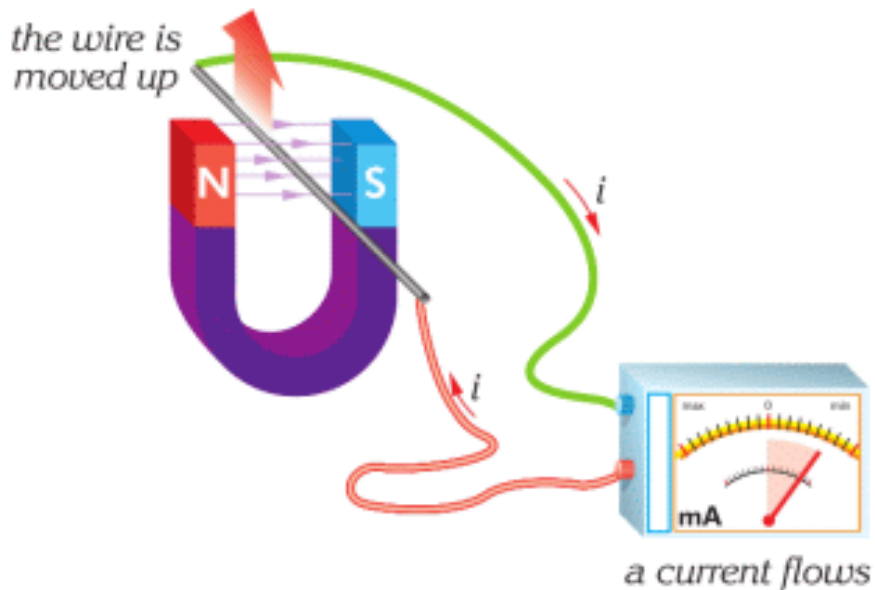

b

Figure 1

Магнитті жоғары-төмен қозғалтқан кезде, ток күшінің бағыты өзгереді. Магнит қозғалмаған жағдайда ток болмайды. Бұл әдіспен ток тудыру электромагниттік индукция деп аталады.

Электромагниттік индукция электр тогын тудырады. Бұл әдісті қолданатын құрылғылар генераторлар деп аталады. Олардың ішінде катушка және магниттер болады. Генераторды айналдыратын механикалық күш болса, генератор сол механикалық энергияны электр энергиясына айналдырады.

Look at the pictures below.

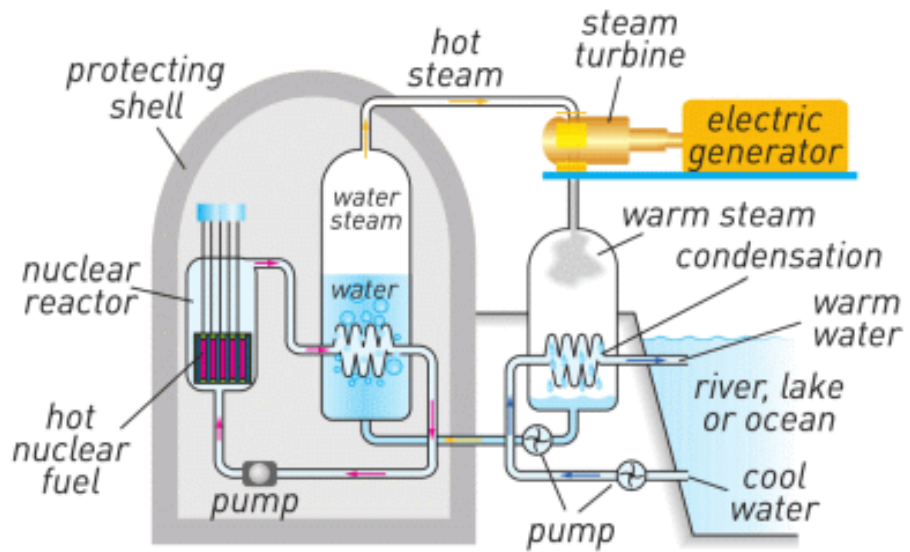
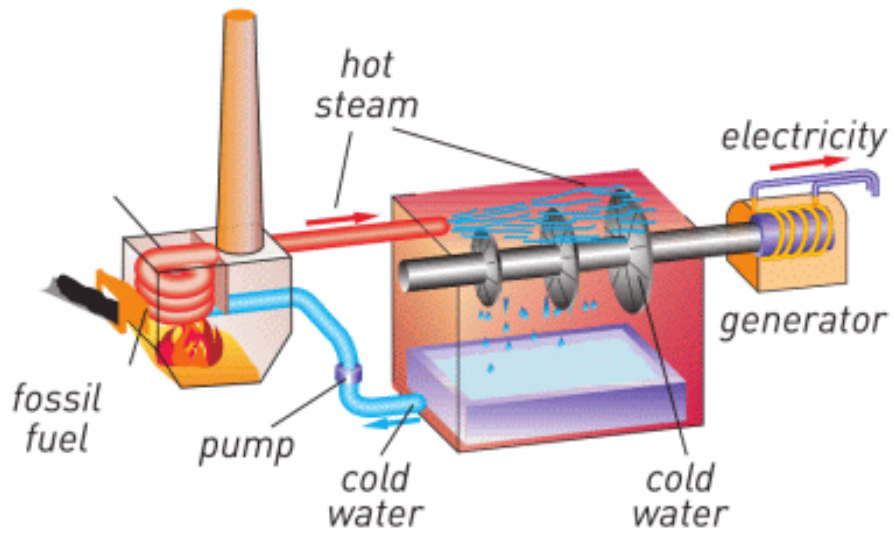

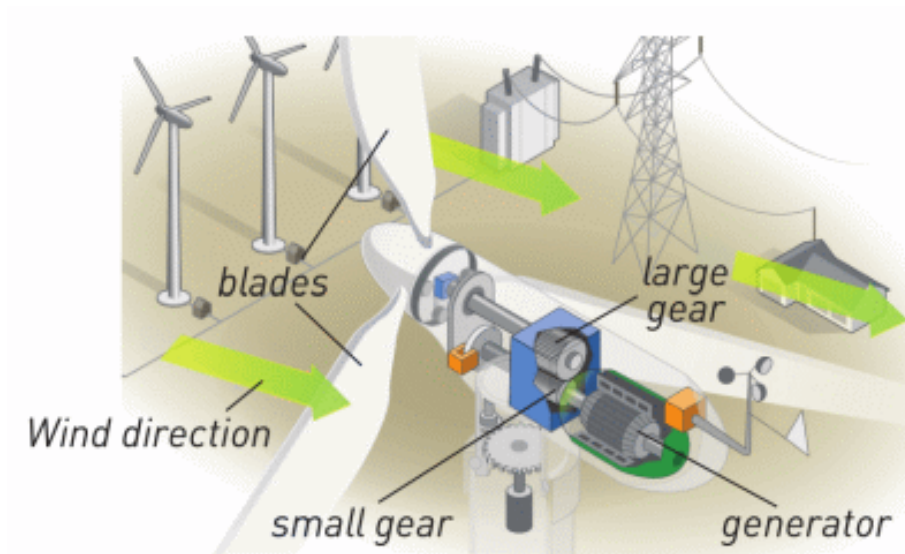
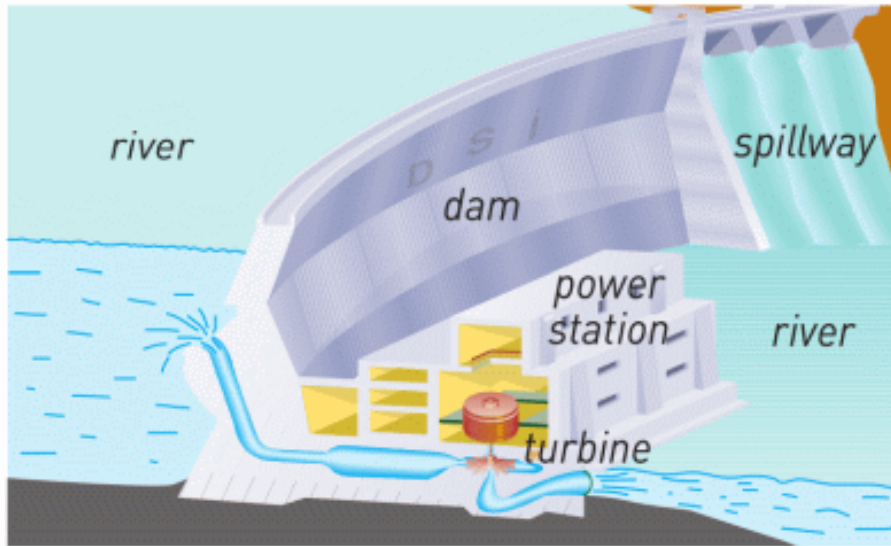

- - What is the source of mechanical energy?
- - How can you name each picture?
- - How are the named parts important in each case? What may their functions be?
- - What can be in common among pictures?

RESEARCH TIME

Power Plants

- - How many power plants are there in Kazakhstan?
- - How would you show them on the map?

Electricity at home

How is electricity delivered to your home? Answer the question using the picture or diagram.

FACT

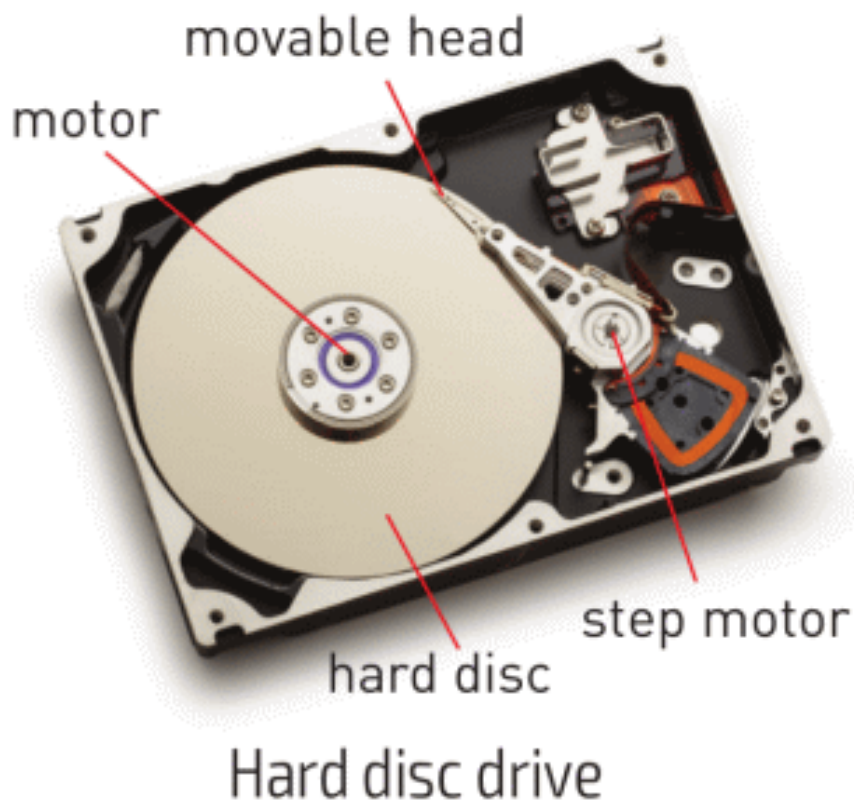

Movable head uses electromagnetic induction to read and write information from hard disk.

ACTIVITY

This is a map. It has several independent regions. These regions have many sources of energy. People need electricity. They have chosen you to solve this problem and build power plants.

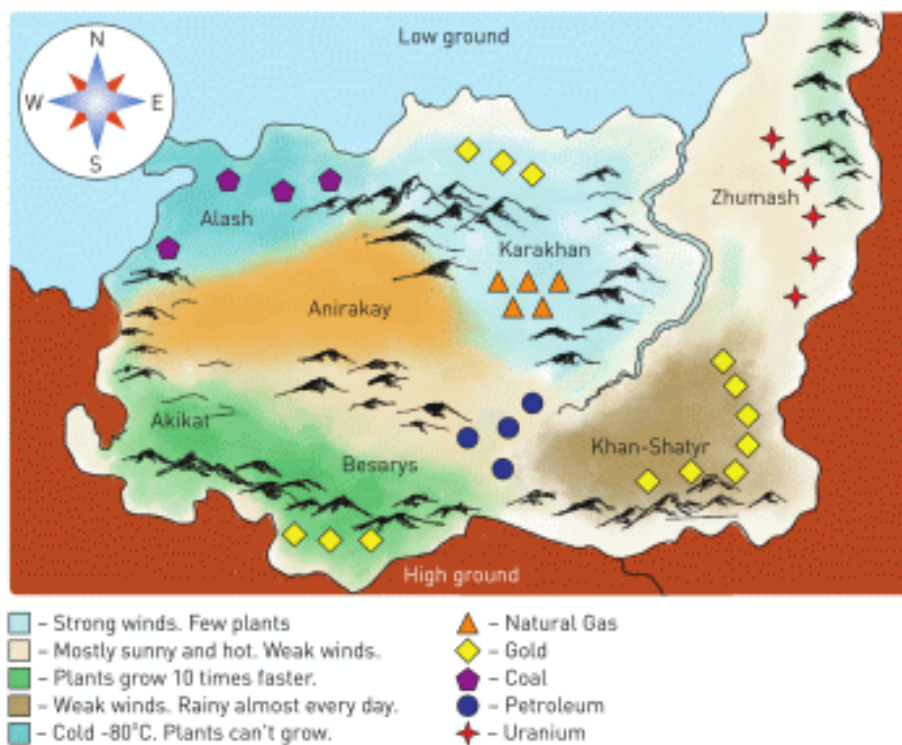

Types of power plant:

1. Water

a) Power: 702 MW

b) Conditions: big flat area.

2. Nuclear

a) Power: 4000 MW

b) Conditions: a lot of water.

3. Fossil

a) Power: 2500 MW

b) Conditions: produces a lot of CO₂, needs lots of plants around.

4. Bio

a) Power: 1000 MW

b) Conditions: a lot of biomass fuel.

5. Solar

a) Power: 40 MW

b) Conditions: sunny and flat regions

6. Wind

a) Power: 45 MW

b) Conditions: strong winds

Questions.

a) How would you solve this problem? Explain your solution.

b) 1 family of 4 people needs about 5 kW of power. How many families in each region can use electricity? Estimate your answers.

RESEARCH TIME

“Kazakhstan Energy - 2050”

- - How would you develop energy production by 2050?
- - What kind of power plants would you build and where?

- - What kind of problems may you face during these years? How would you solve them?

Show them on the map. Give detailed answers. Support them with calculations.

LITERACY

1. Dynamo powers headlights of bicycle when it moves. When the bicycle stops, there is no light. How does dynamo work?
2. How does Ekibastuz GRES-2 Power Station use coal to produce electricity?
3. Why is Bukhtarma hydroelectric power plant is built on the Irtys river? How does it work?
4. Imagine you are on the Moon. How many ways of electricity production can you find there?
5. Search for "Crank Generator" or "Spool Generator" on Youtube. How would you construct such a generator?

ART TIME

Can you imagine life without electricity? What do you do if there is no electricity? Can you write prose or a poem about life without electricity? Write it and read to parents, teachers, and friends.

TERMINOLOGY

to disappear – жойылу / исчезать

condition – шарт / условие

fossil – пайдалы қазбалар / ископаемое

LABWORK 8

TITLE:

Magnetic field

OBJECTIVES:

- To use a compass to explore the direction of the magnetic field of a permanent bar magnet.
- To draw magnetic field lines of a permanent bar magnet.

MATERIALS LIST:

1. permanent bar magnet
2. compass
3. graphing paper

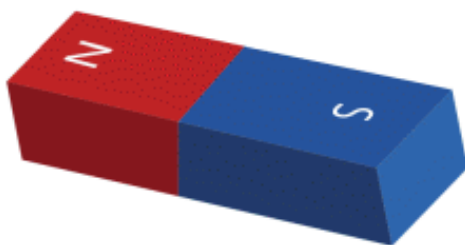

SAFETY:

1. Magnets can generate strong forces. Never place your fingers between two magnets.
2. Do not attempt this exercise with any magnets other than those provided by your teacher for this purpose.

THEORY:

- Why do magnets push or pull on a distance? Why can't you push or pull on a distance?
- Why do we use a compass? How does the compass work? What materials do you need to make the compass?

PROCEDURE:

1. Read the entire lab PROCEDURE, and plan the steps YOU WILL take.
2. Put bar magnet on a graph paper (or notebook).
3. Draw outline of the bar magnet.
4. Put the compass near the bar magnet.
5. Draw the needle of the compass on the graph paper.
6. Move the compass a little.
7. Draw the needle of the compass on the graph paper.
8. Connect the needles.
9. Repeat steps 5-6-7-9 until there is no free space on the graph paper.
10. Clean up your work area. Put the equipment away safely.

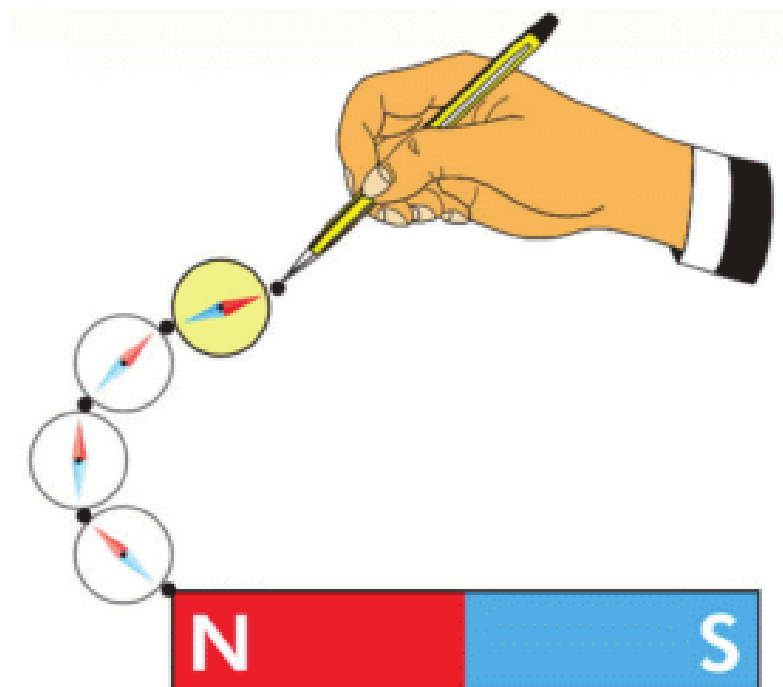

ANALYSIS:

1. What does the arrow of a compass show? Why does the arrow of the compass rotate?
2. Where does the line that connects needles start? Where does it end? What does this line show?

CONCLUSIONS:

How can you use permanent magnets in new ways?

LABWORK 9

TITLE:

Electromagnet and permanent magnet

OBJECTIVES:

- Compare magnetic fields of permanent magnet and electromagnet.

MATERIALS LIST:

1. permanent bar magnet
2. electromagnet
3. power source (battery)
4. connecting wires
5. iron mass set

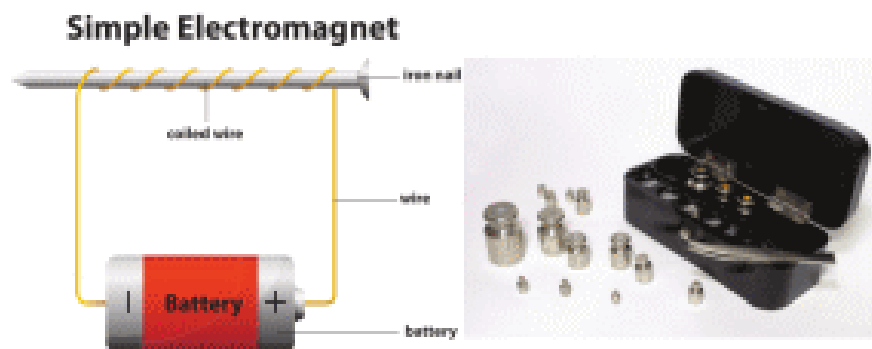
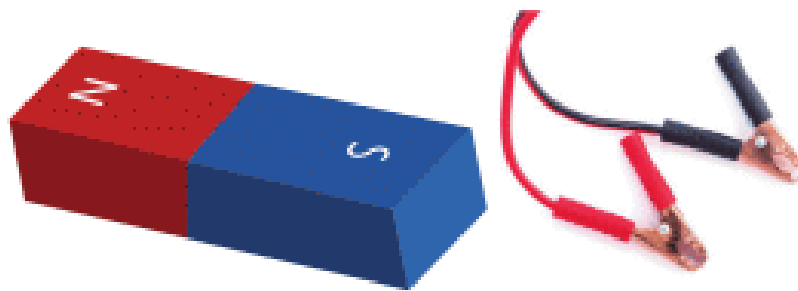

SAFETY:

1. Magnets can generate strong forces. Never place your fingers between two magnets.
2. Do not attempt this exercise with any magnets other than those provided by your teacher for this purpose.
3. Never close a circuit until it has been approved by your teacher.
4. Never rewire or adjust any element of a closed circuit.
5. Never work with electricity near water; make sure the floor and all work surfaces are dry.

6. If the pointer on any kind of meter moves off the scale, open the circuit immediately by opening the switch.
7. Do not attempt this exercise with any batteries or electrical devices other than those provided by your teacher for this purpose.
8. Use a hot mitt to handle resistors, light sources, and other equipment that may be hot. Allow all equipment to cool before storing it.

THEORY:

1. Why does the magnet attract the iron mass set? Why does the magnet not attract wood or plastic objects?
2. Why does the electromagnet attract the iron mass set? Why does the electromagnet not attract wood or plastic objects?
3. Can the electromagnet attract if there is no current in it? Why?

PROCEDURE:

1. Read the entire lab PROCEDURE, and plan the steps YOU WILL take.
2. Take a bar magnet and attach masses to it.
3. Determine the maximum mass that the bar magnet can hold.
4. Take the electromagnet and connect it to the power source.
5. Determine the mass that the electromagnet can hold at the lowest voltage.
6. Increase the voltage and determine the mass that the electromagnet can hold.
7. Repeat step 6 until you reach the maximum voltage.

ANALYSIS:

Maximum mass that bar magnet can attract (kg)

Voltage of power source (V)	Maximum mass that electromagnet can attract (kg)

CONCLUSIONS:

1. At what voltage is the electromagnet equal to the bar magnet?
2. How does the mass that the bar magnet can hold depend on the voltage?
3. Is there any electricity inside the permanent bar magnet?
Why does the bar magnet attract iron objects?

SUMMARY

- According to theory, the magnetism of materials depends on domains inside them. A domain is a group of atoms lined up together in a small region.

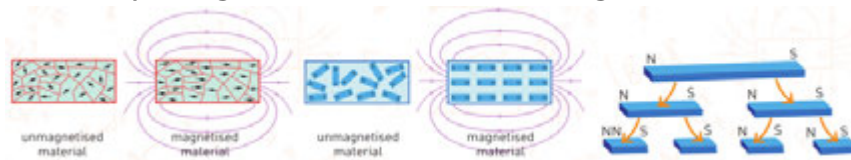

- A motion of charges generates a magnetic field around the wire.
- The trajectory of the magnetic field is circular. It can be clockwise and counter clockwise. In order to find it, we use the right-hand rule. The thumb is directed in the same direction as the electric current. Magnets can attract or repel each other.
- The magnetosphere has great importance for life on the Earth. It acts like as umbrella protecting the Earth from hazardous cosmic rays coming from the Sun.

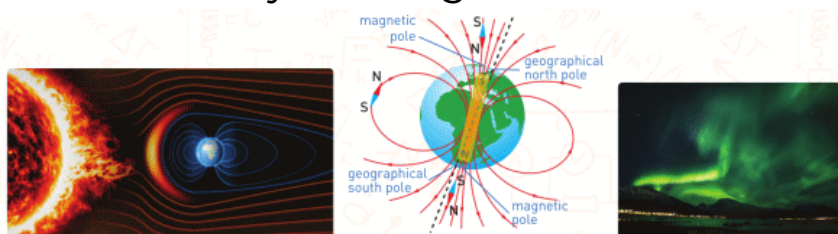

- When the current flows through a wire, an external magnetic field can push the wire and produce a force.
- This force is called magnetic force. Electric motor uses that force converting electric energy into mechanical energy.

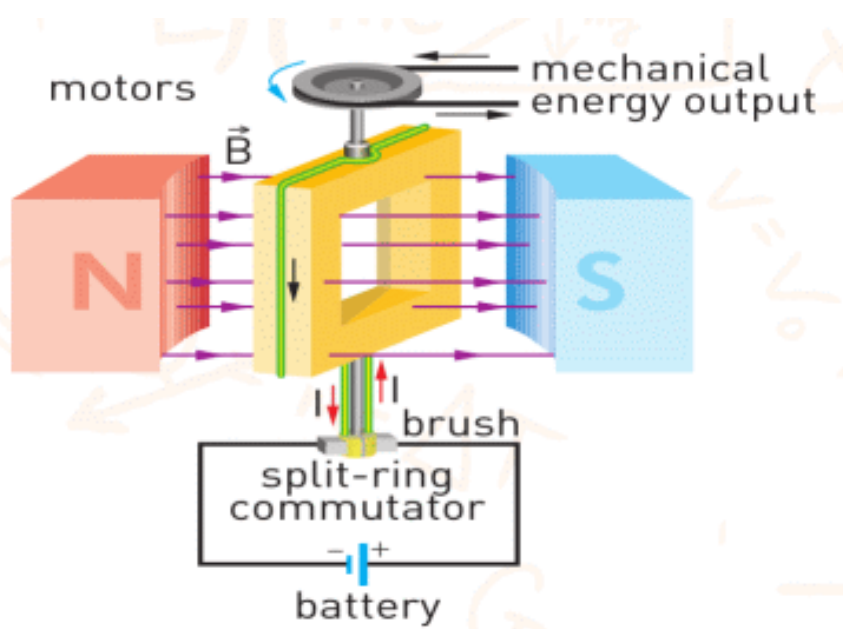

- When you move the magnet back and forth in the coil, the current is generated in the coil. This generation of the electric current is called electromagnetic induction. We use electromagnetic induction to produce electric current.

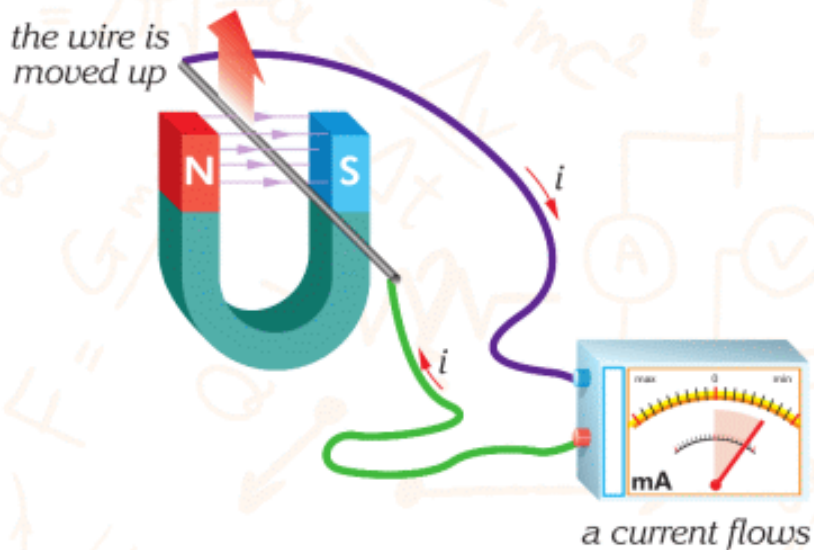

PROBLEMS

ANSWER THE QUESTIONS

1. Draw the magnetic field lines between the magnets when you place as shown below:

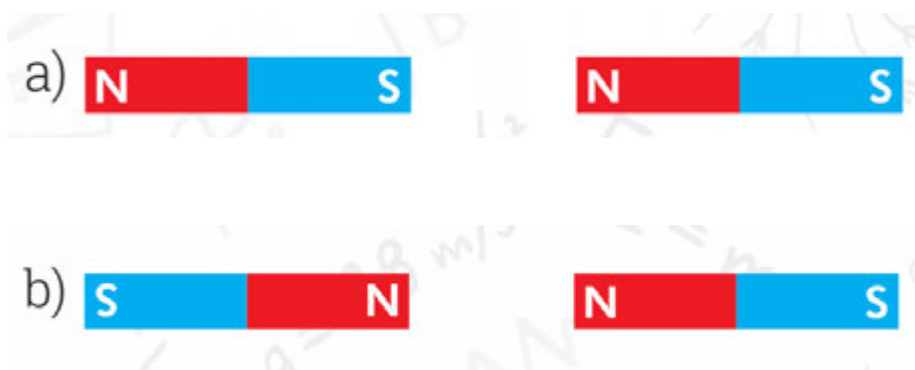

2. What will the direction of the compass needle be if it is placed between the arms of the U-magnet shown in the figure?

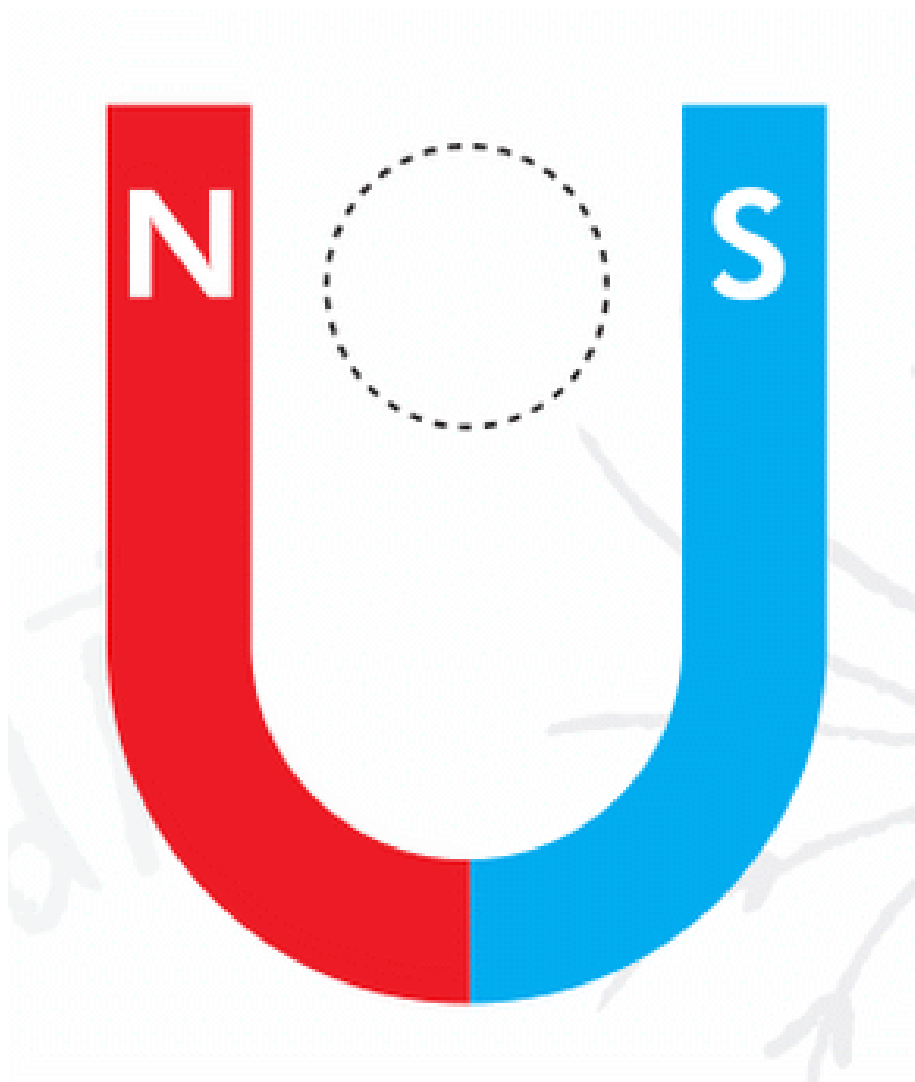

3. Which of the following figures cannot be obtained using bar magnets? Why?

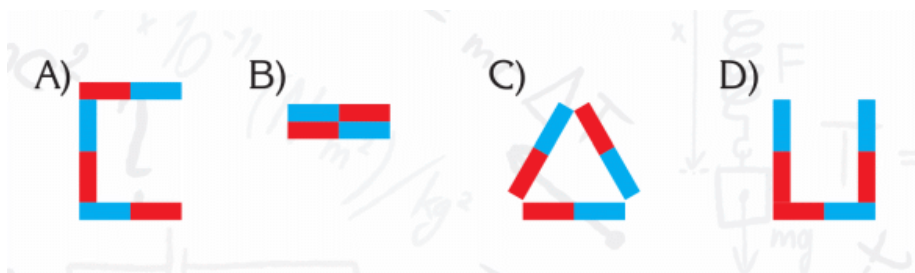

4. Which one of the statements below is not correct with respect to the electromagnet?

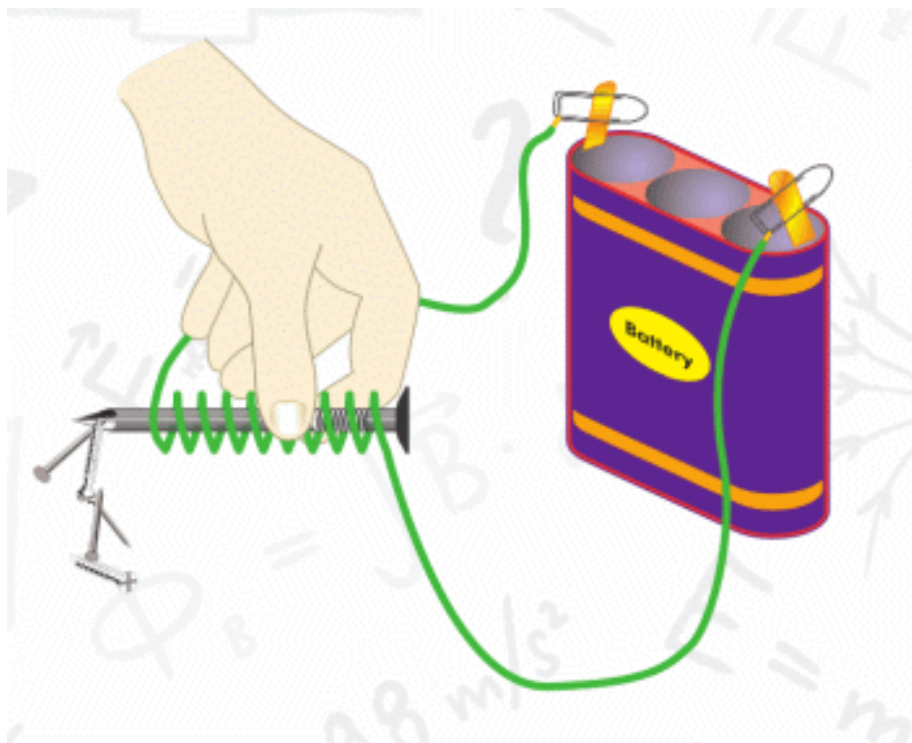

- A) It attracts plastic objects.
- B) The iron produces a magnetic field in the space around it.
- C) One end of the nail becomes a north pole.
- D) Direct current flows through the circuit.

5. In which of the figures below is there no current on the ammeter scale?

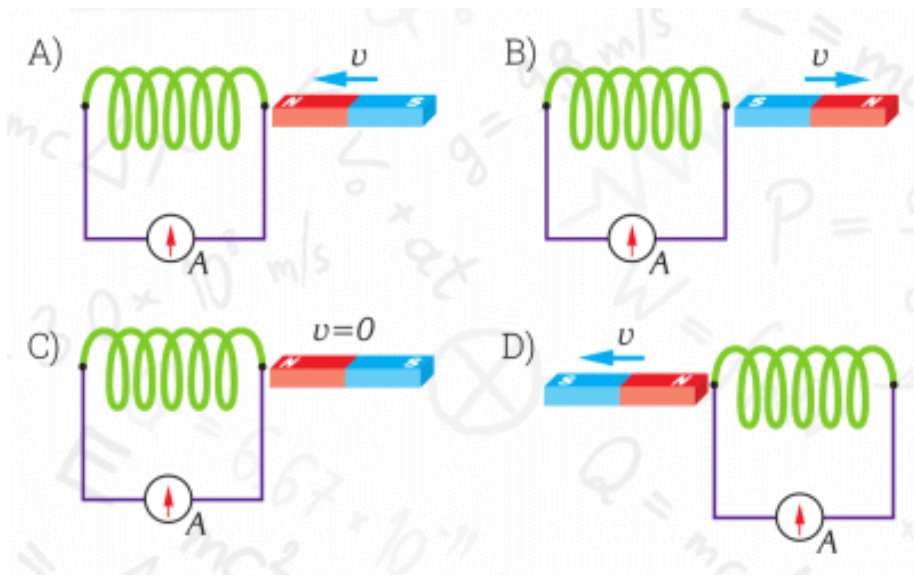

PHYSICS IN LIFE

1. These flashlights work without use of batteries. How?

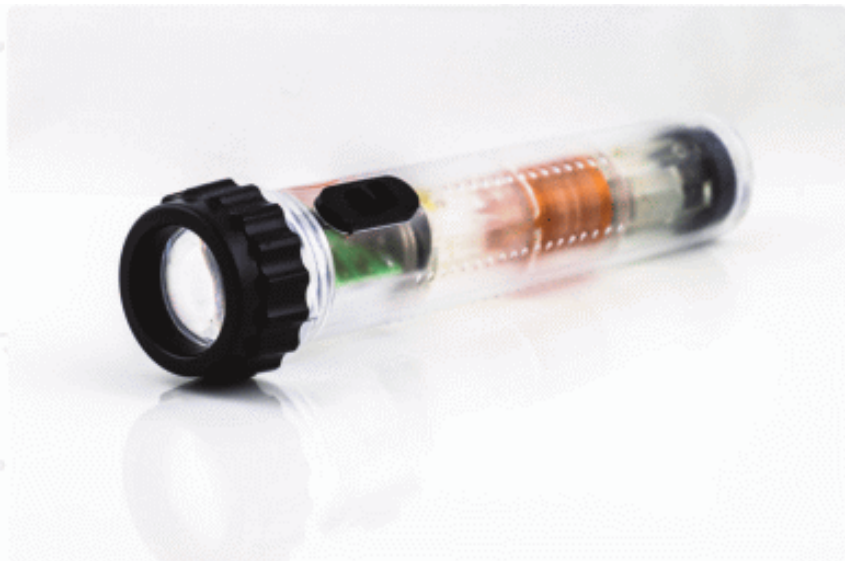

2. When this train moves. It does not touch the ground. Why?

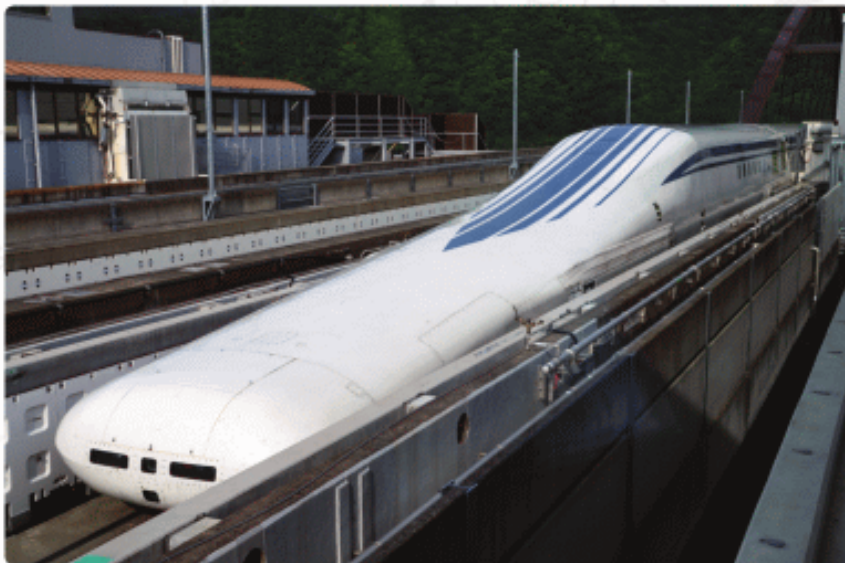

3. Hard disc drives (HDD) are made up of magnetic material. Why?

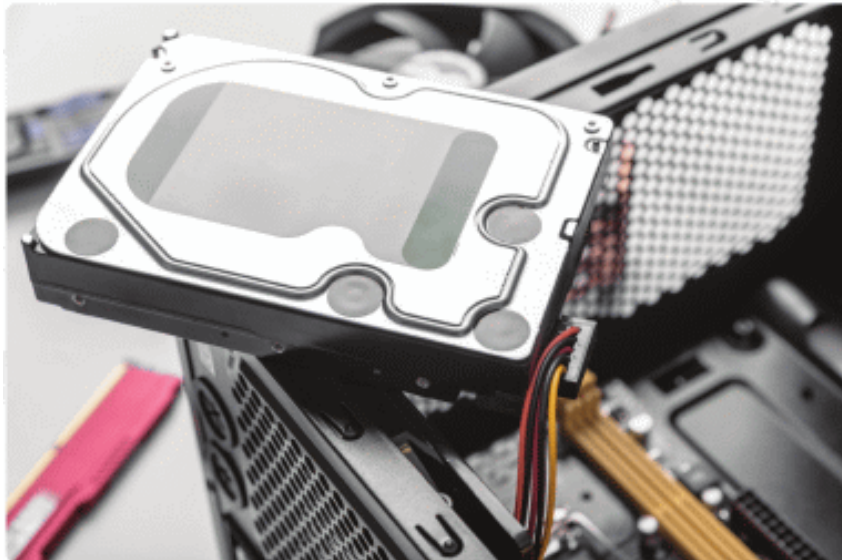

4. MRI is a device that helps thousands of people every day.
How?



CHAPTER 7

OPTICS

7.1 LUNAR AND SOLAR ECLIPSE

7.2 REFLECTION

7.3 CONCAVE MIRROR

7.4 CONVEX MIRROR

7.5 REFRACTION

7.6 TOTAL INTERNAL REFLECTION

7.7 CONVERGING LENS

7.8 DIVERGING LENS

7.9 HUMAN EYE AND OPTICAL DEVICES

LAB WORK 10

LAB WORK 11

SUMMARY

PROBLEMS



7.1 LUNAR AND SOLAR ECLIPSE

YOU WILL:

- - graphically represent solar and lunar eclipses.

QUESTION



Why can we see the full moon only once a month? Why do you see only part of the moon at other time?

LUNAR AND SOLAR ECLIPSE

Жарық - энергияның бір түрі. Табиғаттағы жарықтың негізгі көзі Күн болып табылады. Жарық түзу бағытта таралады.

Бұны төменде көрсетілген демонстрация арқылы түсінуге болады, Figure 1. Қатарынан тұрған үш тақтаның (әрбірінде саңылауы бар) біреуін орнынан қозғаған жағдайда майшамның жарығы көрінбей қалады.

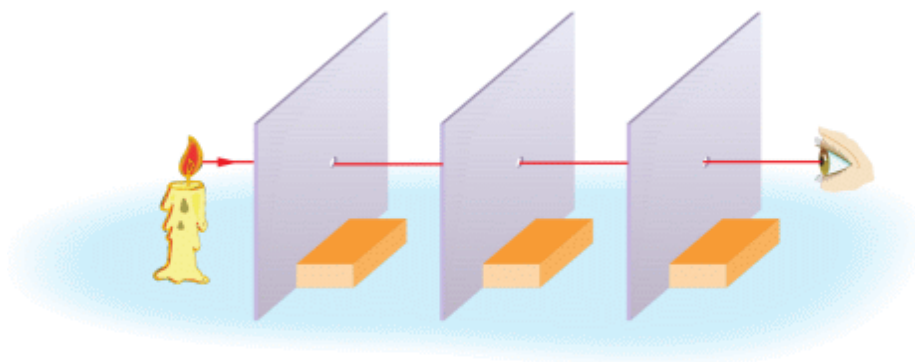

Figure 1

Another proof is a formation of the shadow, Figure 2. Assume light comes from the flashlight through a small hole (point light source). If you put an opaque object in the path of light, dark region (shadow) is displayed on the screen. This dark region is called umbra.

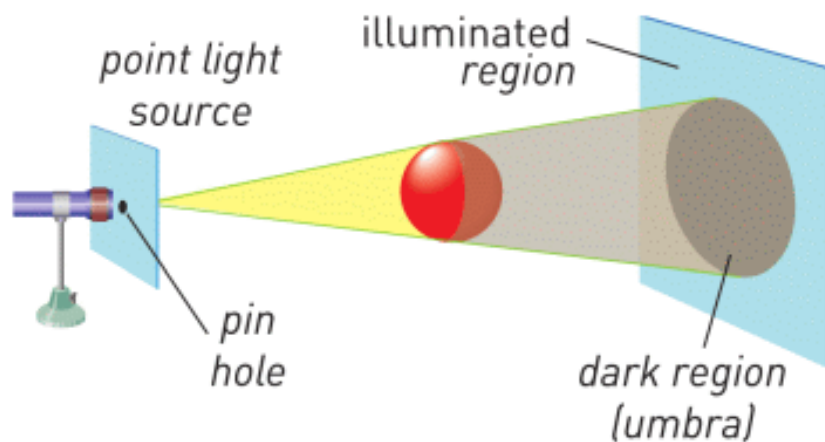

Figure 2

Sometimes the source of light is not like a point. It can be bigger. This time 2 types of shadows can be formed: umbra and penumbra. Penumbra is a region where some light from the source can pass, Figure 3.

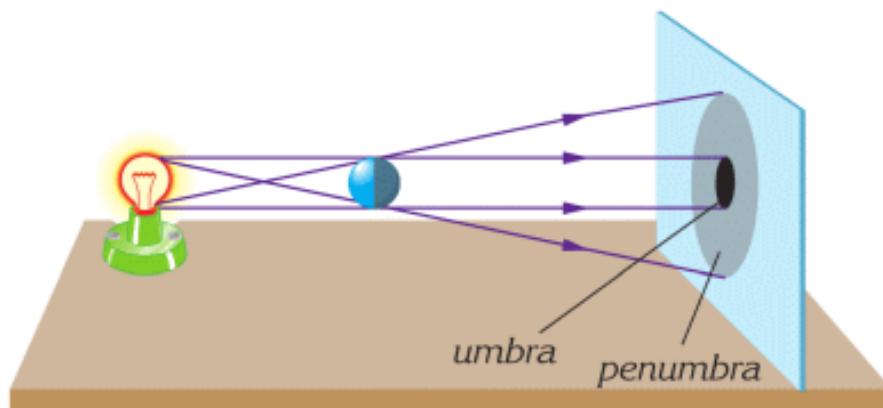

Figure 3

FACT



In ancient times people used sundial (shadow clock).

ACTIVITY

Draw Eclipses

Күннің немесе Айдың тұтылуы кезінде Күн, Ай және Жер бір сызық бойында орналасады.

Күннің тұтылуы

Ай - Күн мен Жердің арасында орналасады. Айдың көлеңкесі Жердің бетіне түседі. Шала және толық көлеңкелер Жердің шағын бөлігіне ғана түседі.

Айдың тұтылуы

Жер - Күн мен Айдың арасында орналасады. Жердің көлеңкесі Айдың бетіне түсіп, Ай толығымен Жердің толық көлеңкесінің ішінде болады.

Күнді үлкен жарық көзі деп қарастыруға болады. Барлық денелерді сфера деп қарастырсақ, Күн ең үлкен, Ай ең кіші сфера болады.

"Зерттеу уақытын" көмек ретінде қолдансаңыз болады.

EXAMPLE

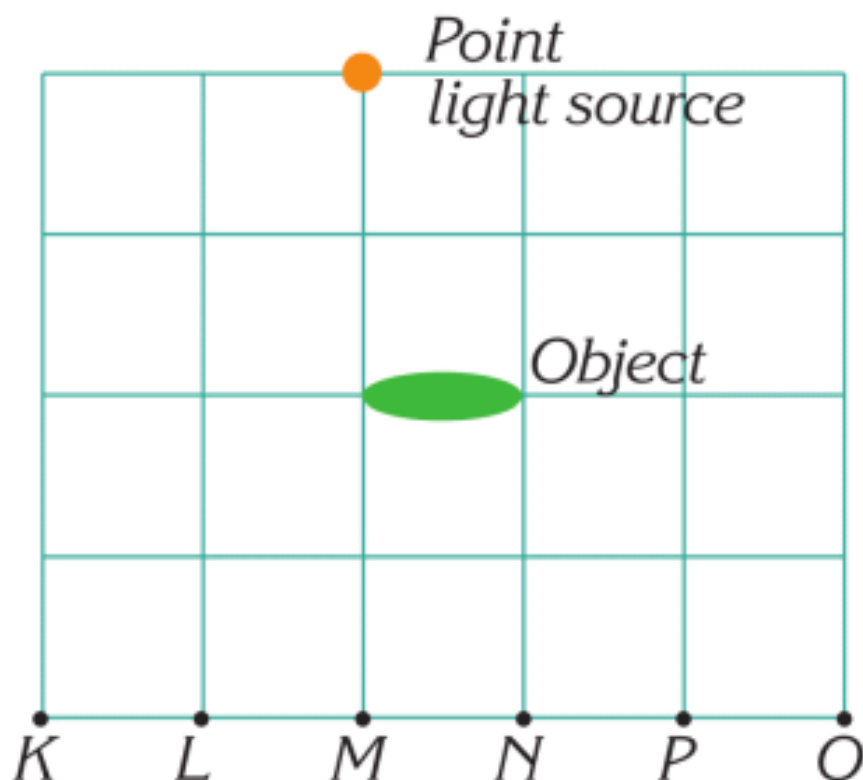

An opaque object is placed in front of a point light source. Show where the shadow forms.

Solution: Shadow is between M and P.

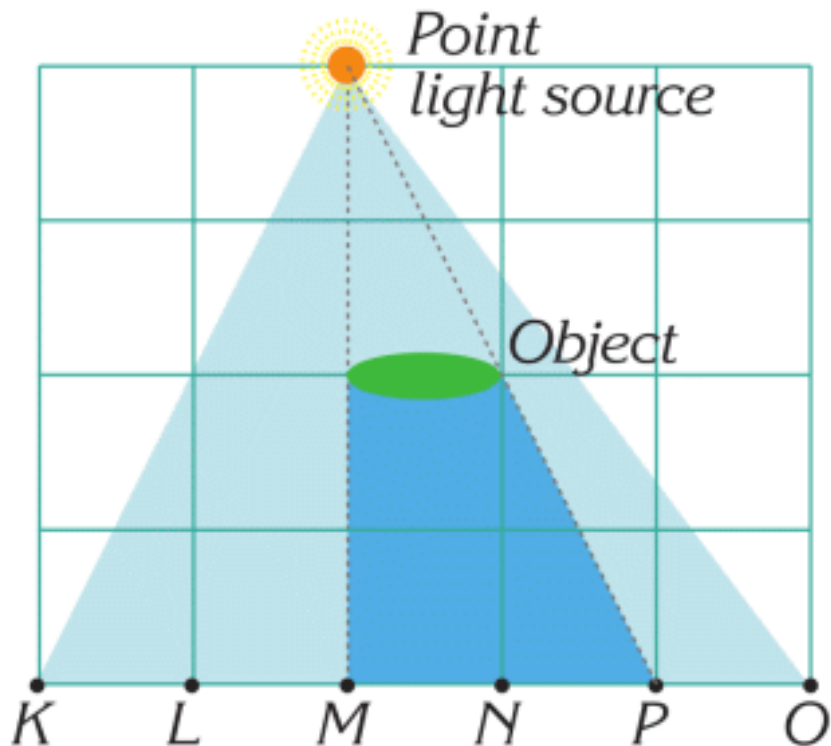

FACT

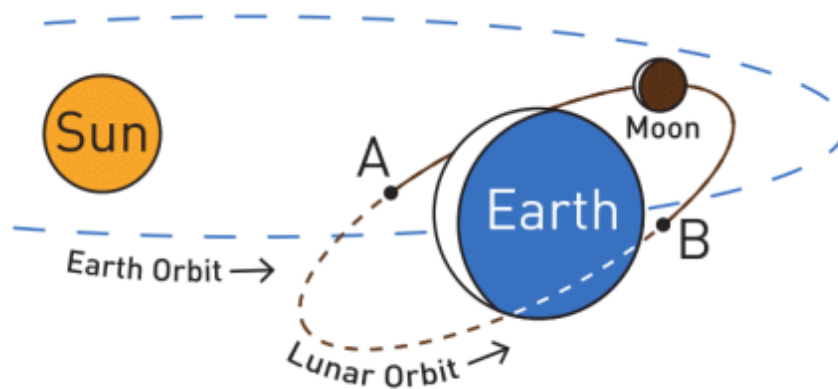

The orbits of the Earth and the Moon are in different planes.

RESEARCH TIME

Materials: soccer ball, tennis ball, flashlight.

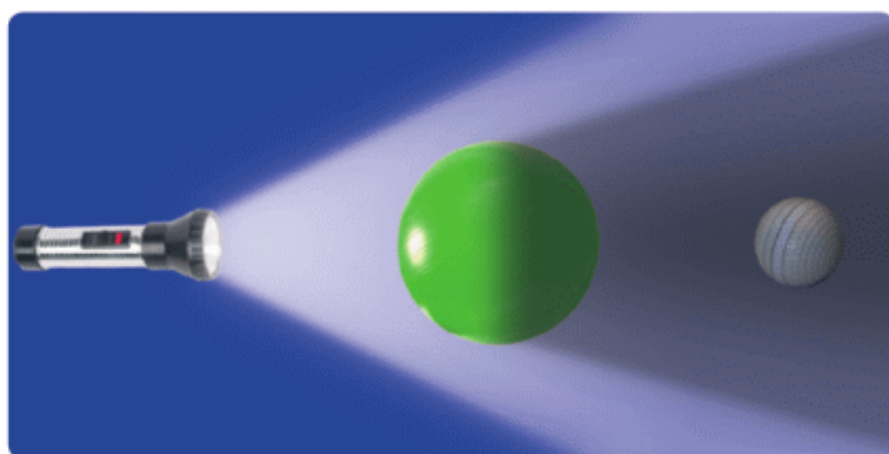
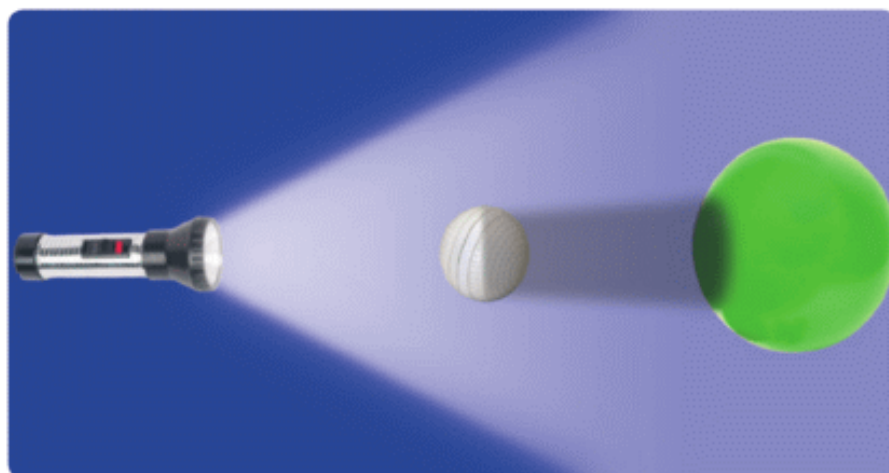

Procedure: Use materials to model solar eclipse and lunar eclipse (look at the figure).

Which case does have a penumbra? Why?

LITERACY

1. A football match takes place late in the evening. Each player has four shadows. Why?
2. What is light?

3. Why do objects form shadows? How can you define shadow?
4. How can light travel in curved lines?
5. Graphite and diamond have same atoms. Why is one of them transparent and another is opaque?
6. When metals are hot, they can produce light. For example, light bulb. How do you think it works?

ART TIME

Play a “shadow theatre”. Show it to parents, teachers, and friends.

TERMINOLOGY

light – жарық / свет

shadow – көлеңке / тень

umbra – толық көлеңке / полная тень

illuminate – жарықтандыру / освещать

penumbra – жартылай көлеңке / полутень

opaque – мөлдір емес / непрозрачный

transparent – мөлдір / прозрачный

7.2 REFLECTION

YOU WILL:

- - experimentally determine relationship between the angle of incidence and the angle of reflection;
- - explain and give examples of regular and diffuse reflection;
- - plot image in plane mirror and list its properties.

QUESTION



The Moon does not produce light, but we can see it. Why?

REFLECTION

Біз айналадағы заттарды жарықтың көмегімен көреміз. Жарық денелердің өзінен шығуы мүмкін, немесе шағылуы мүмкін. Күн мен жұлдыздардың көрінуі, олардың өздерінің жарық көздері болуынан туындайды. Ал, Ай және басқа планеталар өздері жарық шығармаса да, жарық олардың бетінен шағылып көзге көрінеді, Figure 1.

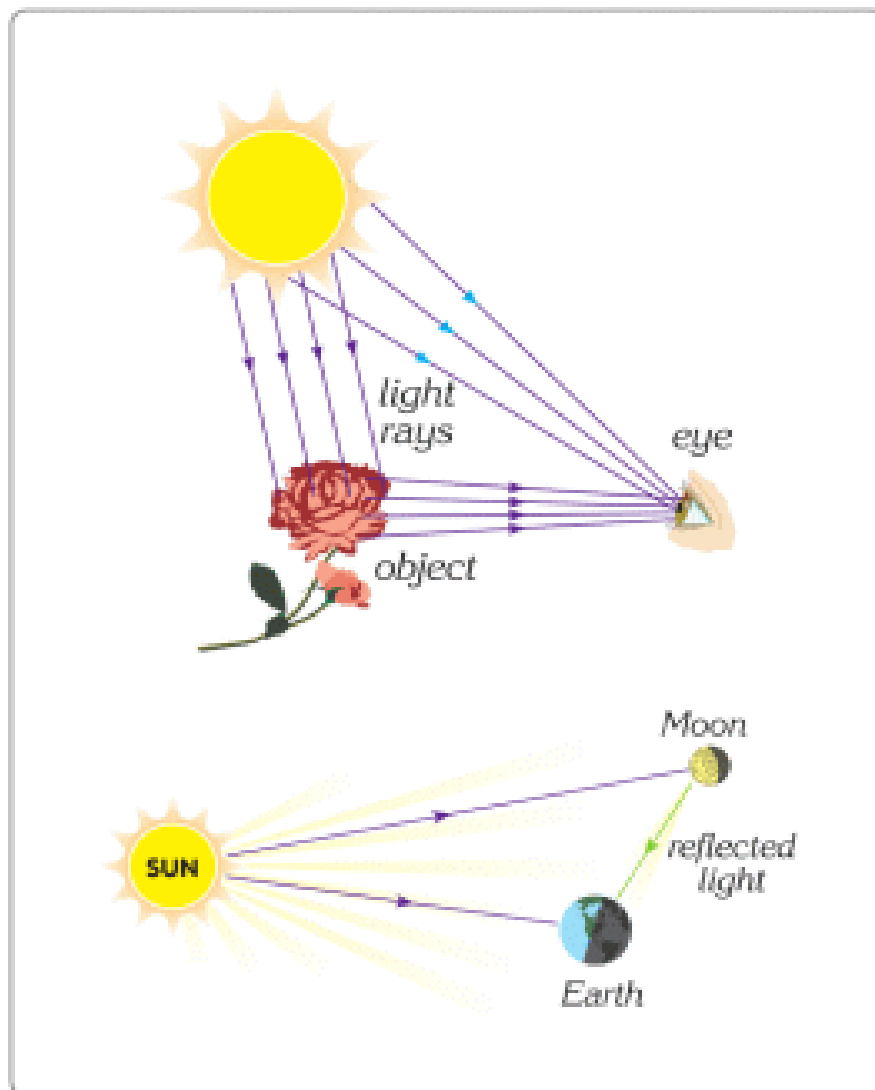

Figure 1

Жарық сәулесі айна бетіне түскенде, айнадан шағылып, шағылған сәуле ретінде кері қайтады. N - айна

жазықтығына перпендикуляр бағытталған нормаль векторы, Figure 2.

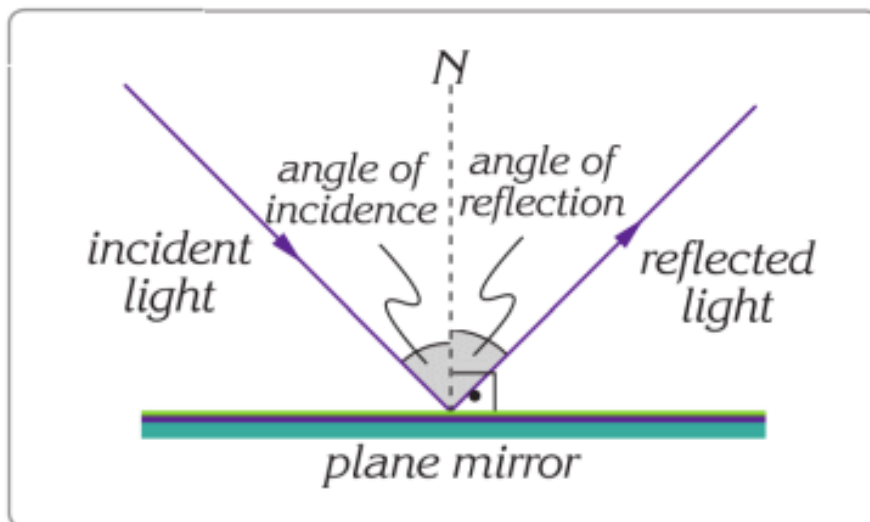

Figure 2

N мен түскен сәуле арасындағы бұрыш түсу бұрышы деп аталса, N мен шағылған сәуле арасындағы бұрыш шағылу бұрышы деп аталады, Figure 2.

Жарық сәулесінің шағылуының басты ережелері:

1. Түсу бұрышы шағылу бұрышына тең болады.
2. Түсу сәулесі, шағылу сәулесі және N векторы бір жазықтықта жатады.

Көптеген денелер жарықты әртүрлі бағытта шағылдырады.

Алайда, айна және металл секілді беті тегіс заттардан жарық бір бағытта шағылады.

Шағылудың бұл түрін айналық немесе бағытталған шағылу деп атаймыз, Figure 3.

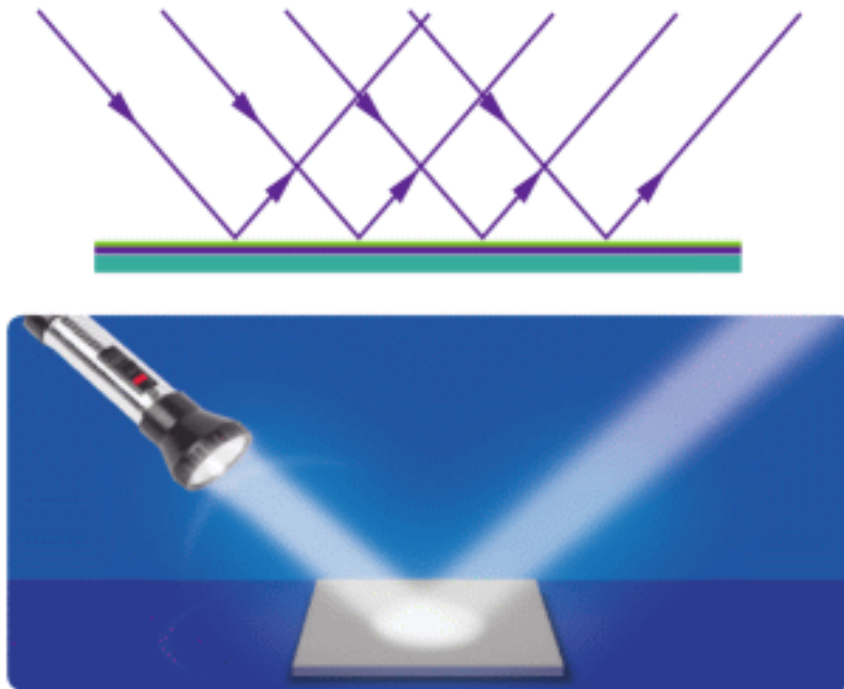

Figure 3

Көптеген денелердің беті тегіс емес, кедір-бұдыр болып келеді. Мысалы, қағаз, жапырақ, қабырғалардың беттерін келтіруге болады. Бұндай беттерден жарық әртүрлі бағытта шағылады. Шағылудың бұл түрі шашыраңқы немесе диффузиялық шағылу деп аталады, Figure 4.

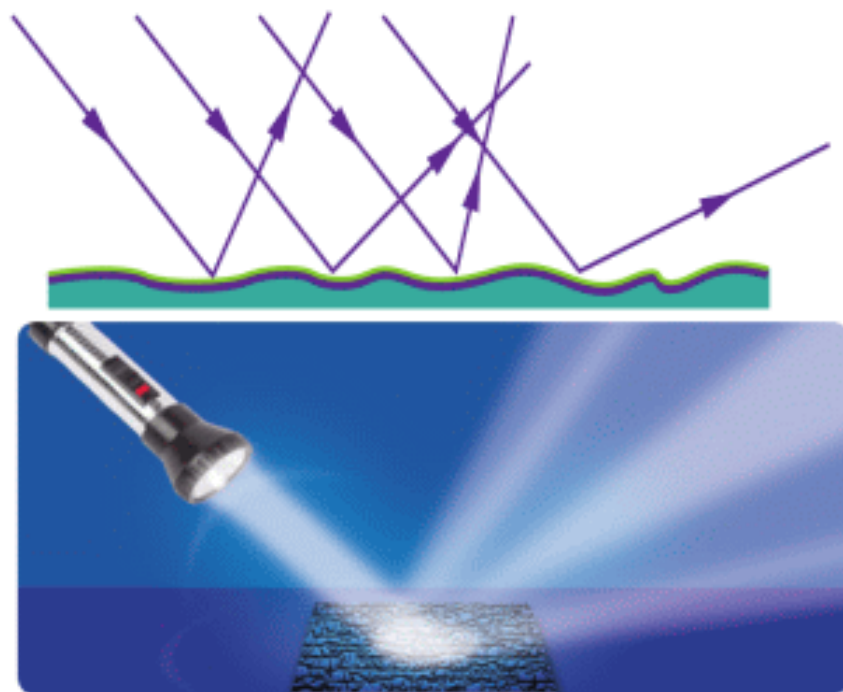

Figure 4

IMAGE FORMATION IN A PLANE MIRROR

A plane mirror forms an image. We can draw the position of this image. To construct an image we need to draw at least two rays. When we draw rays, we apply the law of reflection, Figure 5.

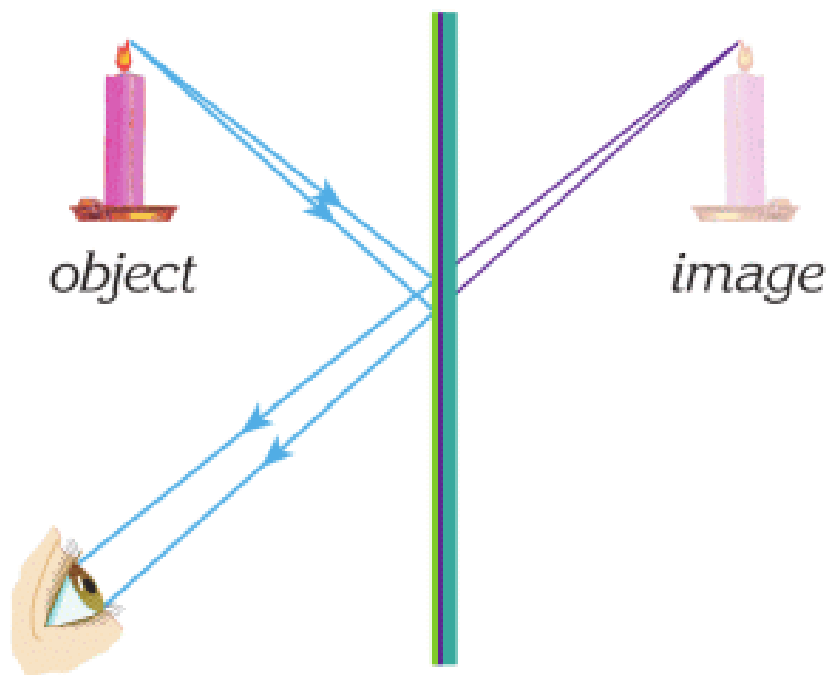

Figure 5

An image in the plane mirror has the same properties (equal size and equal distance from a mirror) as an object, Figure 6. However, the image is left-right reversed.

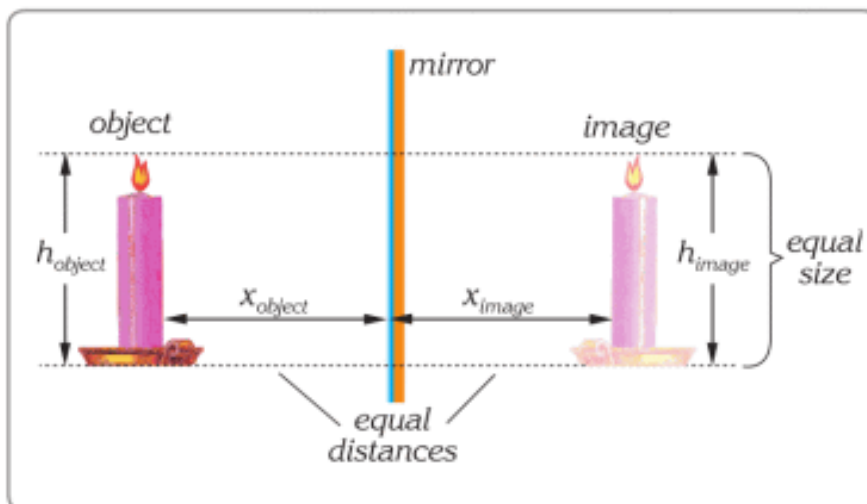

Figure 6

ACTIVITY

"Name in the mirror"

Write your name on paper so you can read it in the mirror.

EXAMPLE

A light strikes a plane mirror at an angle of 40° with the normal:

- Draw a diagram showing the incident ray.
- What is the angle of reflection?
- What is the angle between the incident and the reflected rays?

Solution:

- The incident ray strikes the mirror as in the figure below.

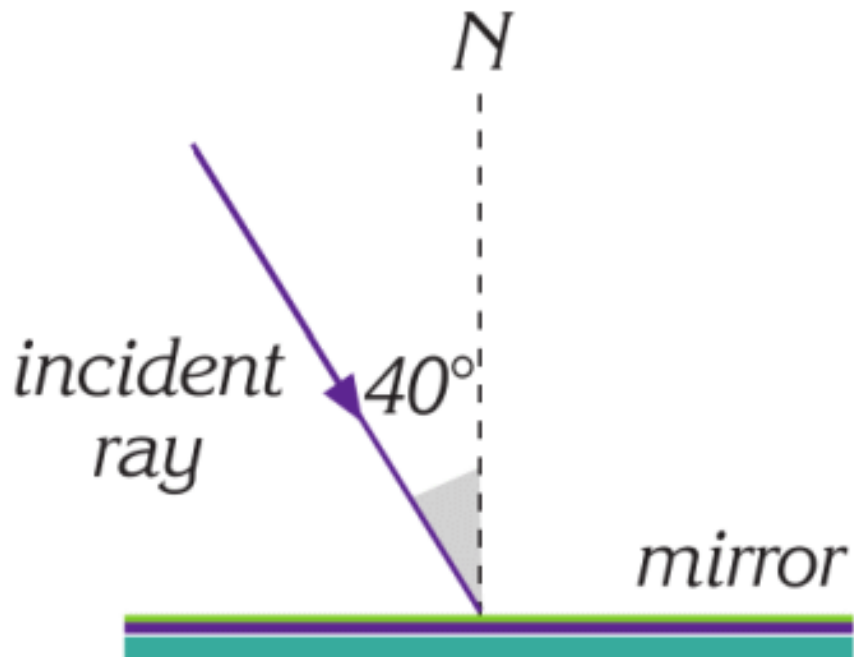

b. The reflected ray makes the same angle as the incident ray.

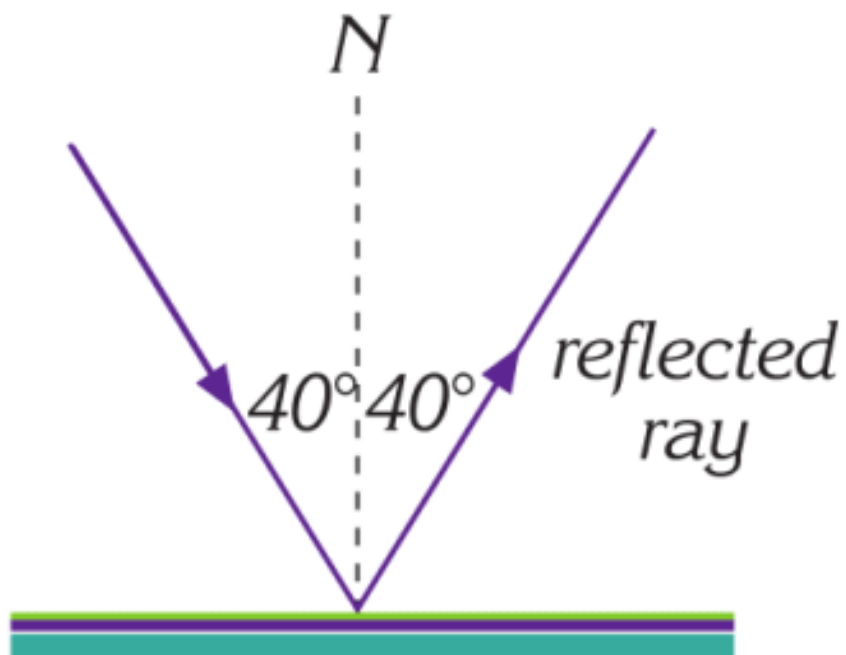

c. The angle between the rays is

$$40^\circ + 40^\circ = 80^\circ$$

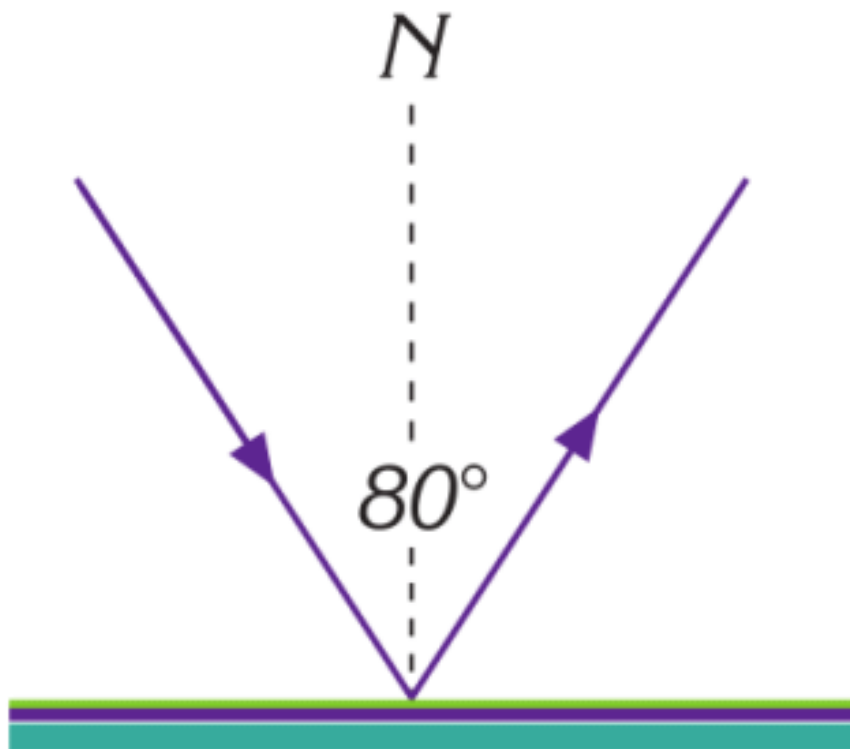

EXAMPLE

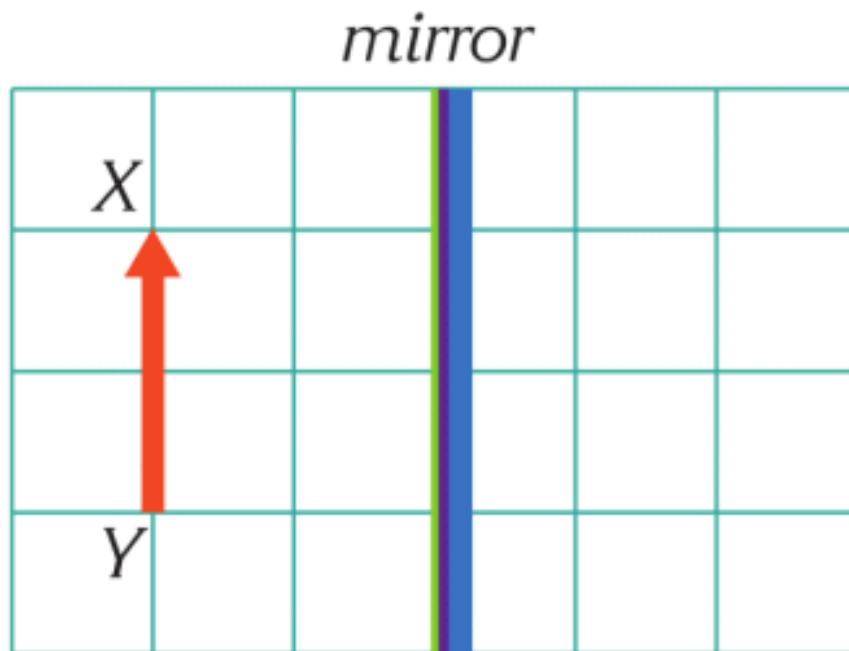

Find the image of the arrow in the mirror.

Solution:

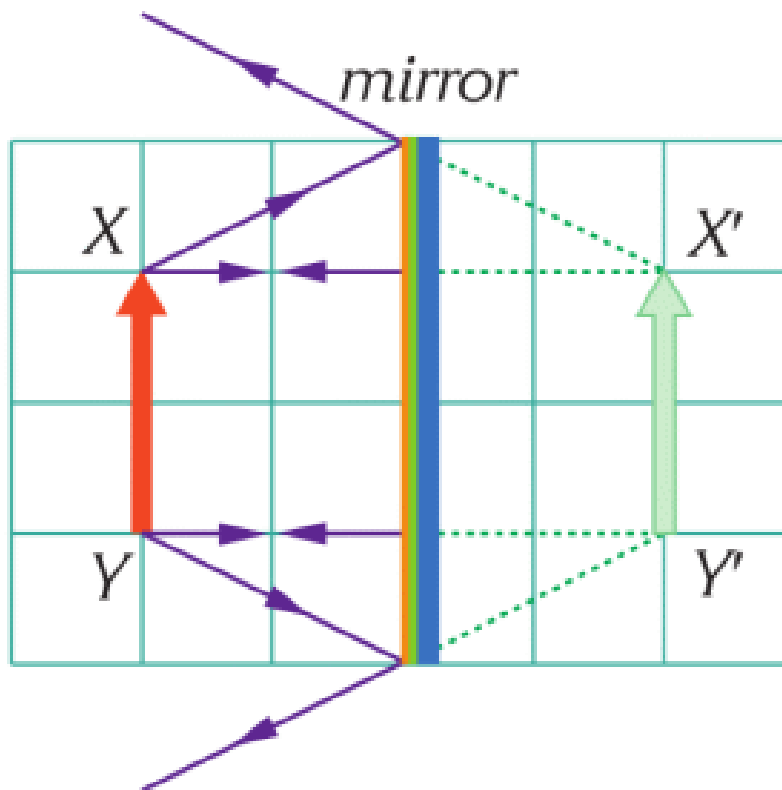

We need at least two rays from a point to draw its image. We use the rules of reflection to draw the image. Image is the same size and the same distance to the mirror as the object.

LITERACY

1. Why can you see a reflection in the mirror? Why you cannot see a reflection in a paper?
2. What materials do you need to make a mirror? How can you make a mirror?
3. Why snow is white?
4. Why do we use fog (or smoke) to see laser light?
5. Why does space seems black?
6. Why do objects have colour? What is colour? How do you see colours?

7. How do you understand the words "left-right reversed"?
8. Draw the reflected rays reflected from the mirrors in the figures.

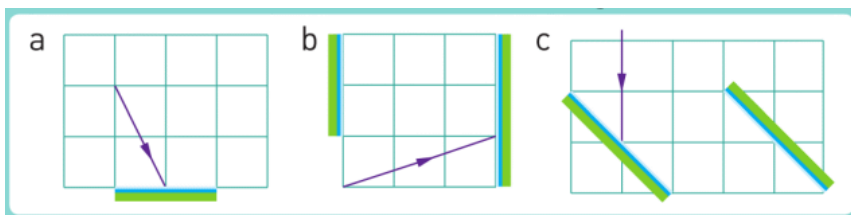

9. Draw the image of the figures below in the plane mirrors.

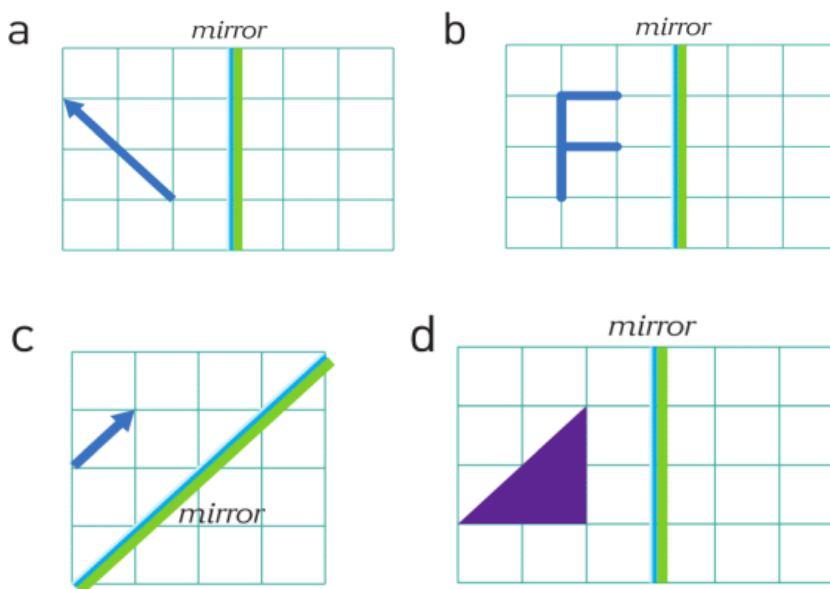

ART TIME

Make theatre play about 'Mirror'. Show this play to your parents, teachers and friends.

TERMINOLOGY

to reflect – шағылу / отражаться

incident ray – бастапқы түскен сәуле / падающий луч

smooth – тегіс / гладкий

rough – қисық, қырлы / шершавый

7.3 CONCAVE MIRROR

YOU WILL:

- - draw a ray diagram of the image for spherical mirrors and list the properties of the image.

QUESTION



What is happening in the figure below?

CONCAVE MIRROR

Ойыс айналар көлік шамдарында, макияж айналарында және күн пештерінде қолданылады, Figure 2.

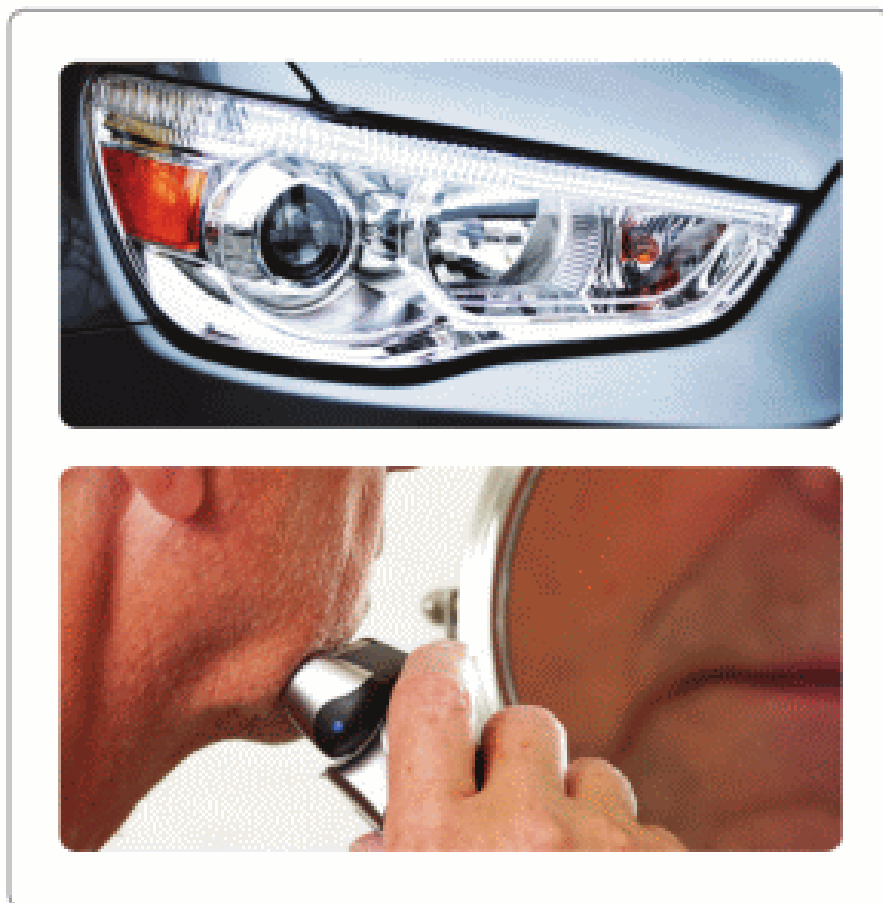

Figure 2

Параллель сәулелер ойыс айна бетінен шағылып, бір нүктеде қиылысады. Бұл нүкте айнаның фокусы деп аталады. Фокус нүктесі F деп белгіленеді, Figure 1. Сфералық беттің центрі мен айнаның фокус нүктесі арасындағы қашықтық айнаның фокус қашықтығы деп аталады. Суретте C және P нүктелері аралығы фокус қашықтығының екі есесі болып табылады.

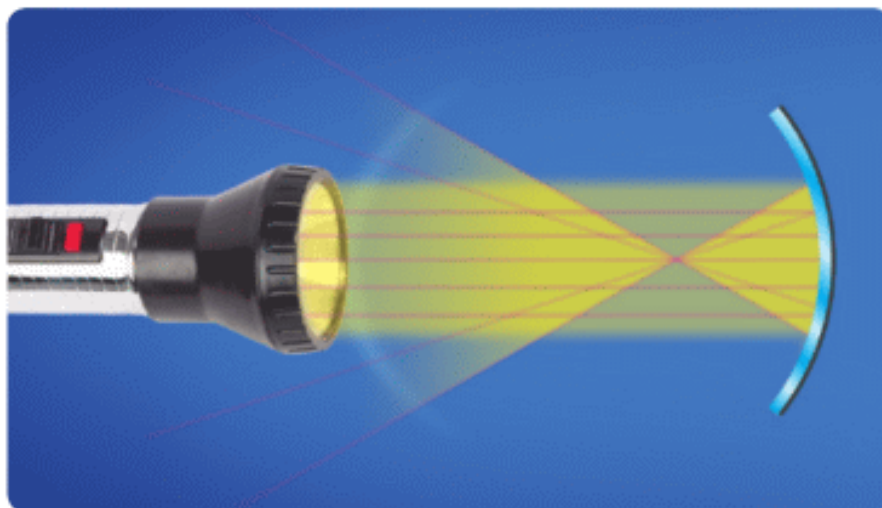

Figure 1

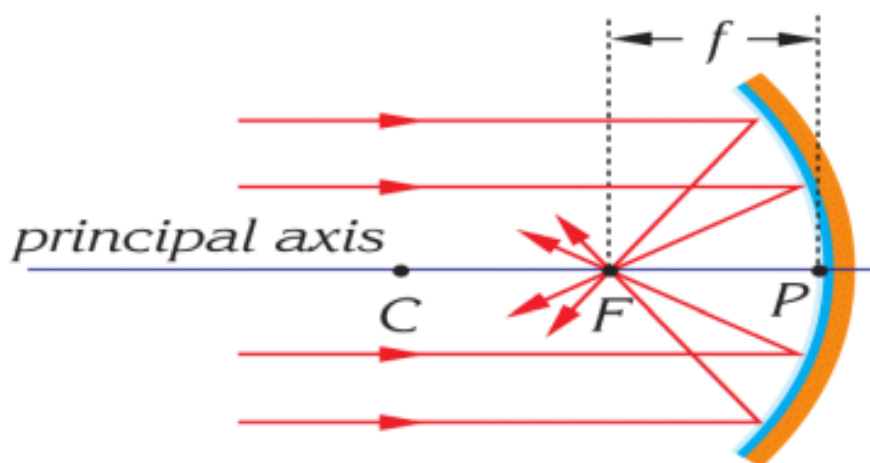
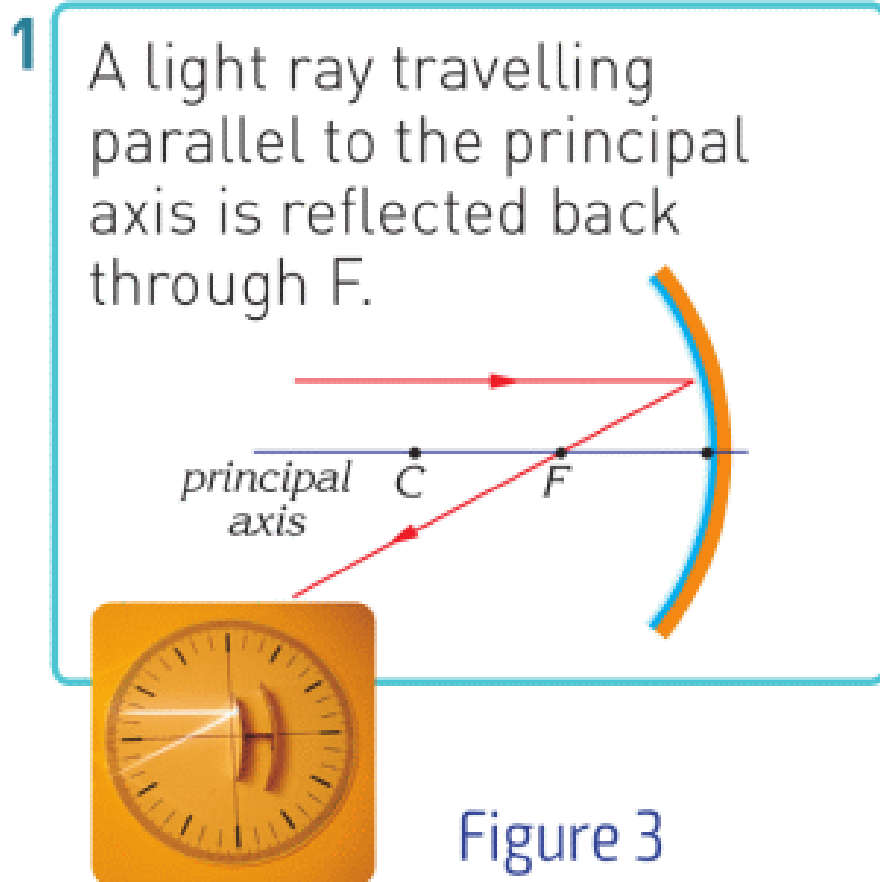

Figure 1

Ойыс айнаға қараған кезде өзіңізді төңкерілген және кішірейген, немесе үлкен және тура етіп көруіңіз мүмкін. Бұл құбылысты түсіну үшін ойыс айнаға арналған сәулелерді қарастырайық.

Ойыс айнада кескін алу үшін сәуленің 4 түрі қолданылады, Figure 3.



- 2 A light ray passing through the centre (C) is reflected back again through the point C.

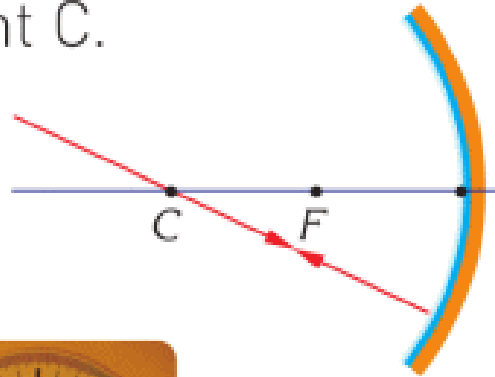

Figure 3

3

A light ray passing through F is reflected back parallel to the principal axis.

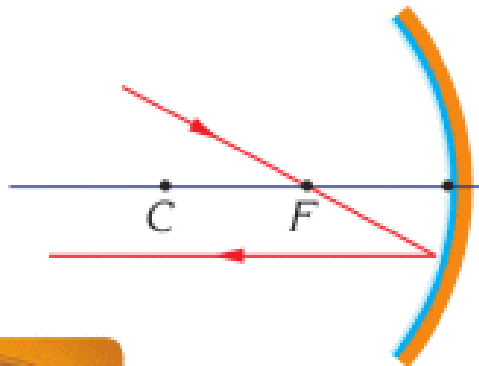

Figure 3

4

The angle of incidence of the light striking the pole is equal to the angle of reflection.

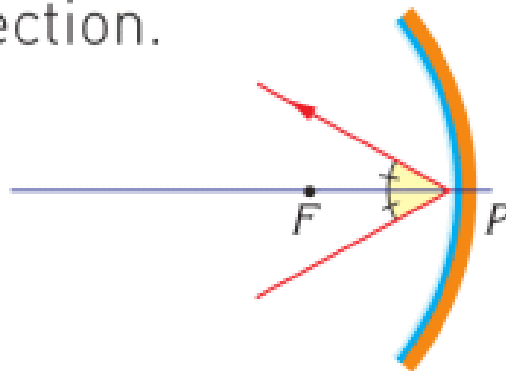
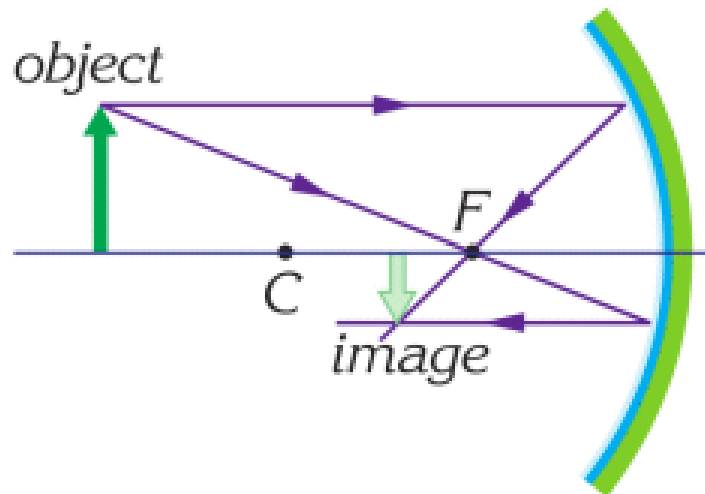

Figure 3

Кескінді салу үшін, кез келген 2 сәулені таңдаймыз. Ол үшін Example 1,2,3 арасынан 1 және 3 нөміріндегі сәулелерді алуға болады. Осы шағылған сәулелердің қиылысу нүктесі дененің кескінін анықтайды.

Сәулелердің осы мысалдардағы кескіндерін шын кескін деп атаймыз (кескіндер шағылған сәулелердің қиылысуынан пайда болады).



Example 1

- a. beyond the C
- b. smaller than the object
- c. real
- d. inverted

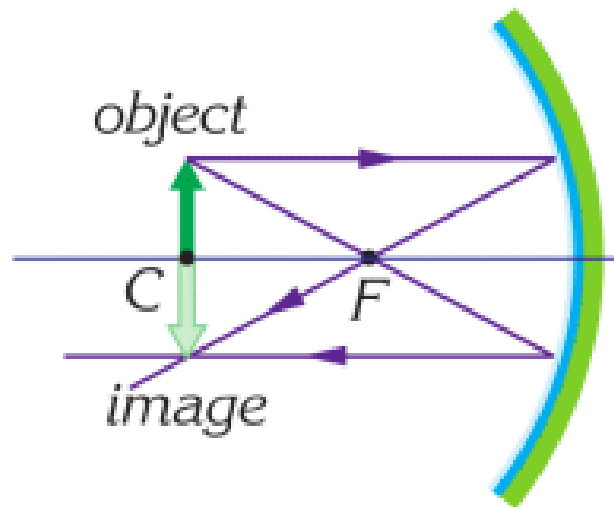

Example 2

- a. at C
- b. the same size as the object
- c. real
- d. inverted

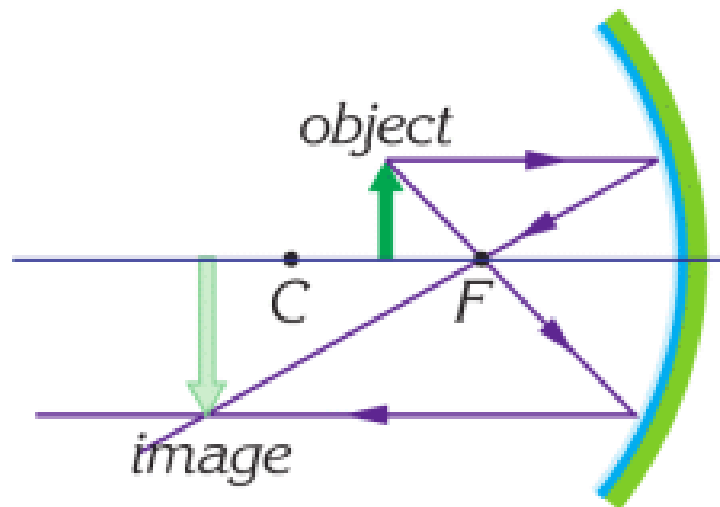

Example 3

- a. between C and F
- b. larger than the object (magnified)
- c. real
- d. Inverted

Sometimes we can use Special ray 1 and 2 as shown in example 4 and 5.

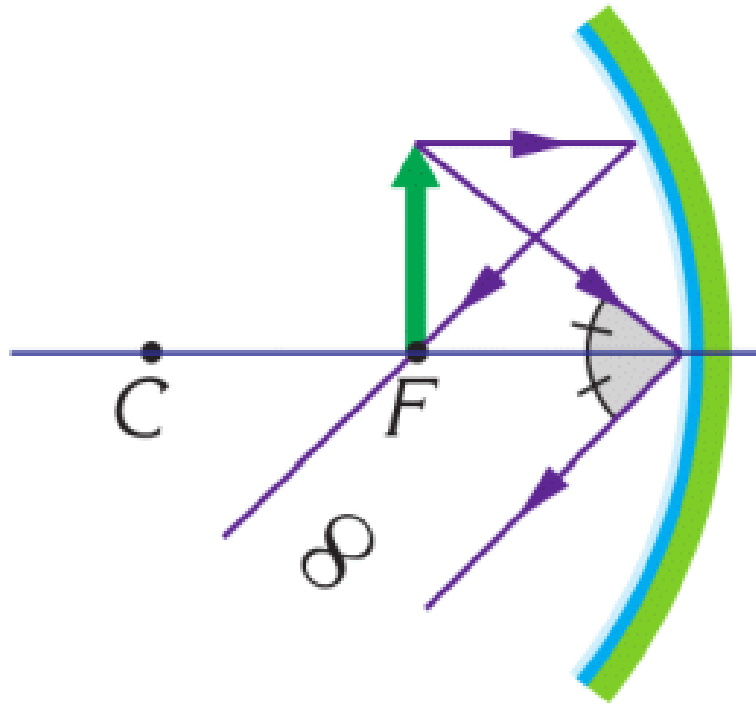

Example 4



Example 5

The image of this object is at infinity because reflected rays are parallel. This property is used in headlights.

In this example reflected rays never intersect. That is why we imagine that they start at an imaginary point. Since the reflected rays do not intersect, we call this image as virtual image.

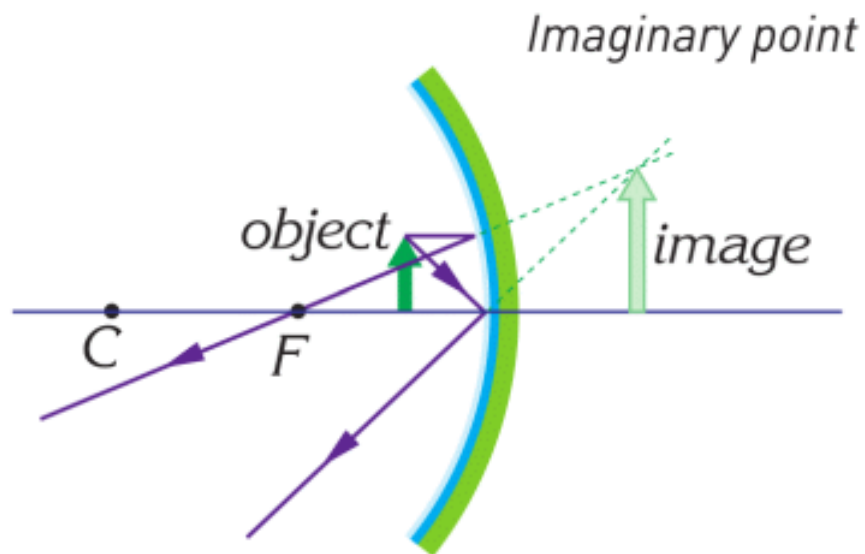

- a. behind the mirror
- b. larger than the object (magnified)
- c. virtual
- d. upright (erect)

EXAMPLE

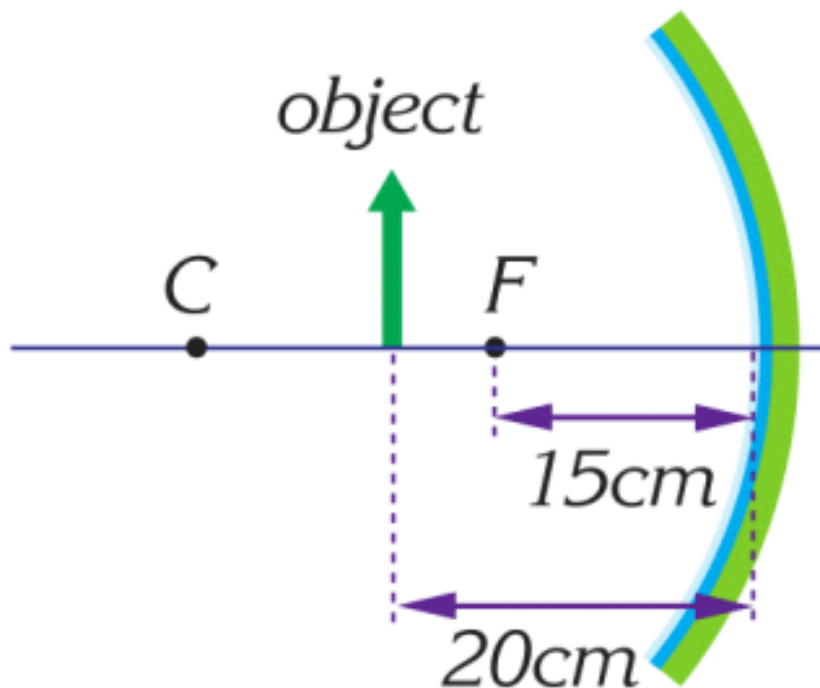

An object is 20 cm away from a concave mirror. Its focal length is 15 cm.

- a. Draw the position of the object.
- b. What properties does the image have?

Solution:

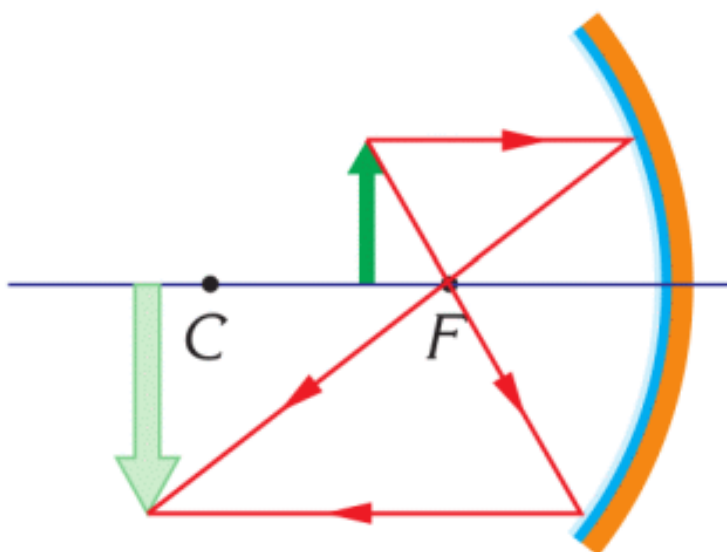

When we draw two special light rays (for example 1 and 3) and their reflection we obtain the image.

It is real, magnified, and inverted.

FACT



Doctors use a frontal reflector to look inside of throat and ears. The frontal reflector is a concave mirror that reflects light in the throat and ears.

RESEARCH TIME

Concave mirror



Materials: aluminium foil, a plastic bottle, scissors, glue.

Procedure: Use materials to make a concave mirror. Shine light on your mirrors. Observe results.

LITERACY

1. Why do you appear to be same in plane mirror? How do rays travel from plane mirror to your eyes?
2. Why do we use concave mirrors for makeup or shaving? How do rays travel from concave mirror to your eyes?

3. A concave mirror has the focal length of 20 cm. The distance between the object and mirror is 10 cm. Draw a ray diagram of the mirror, the object and the image. Use the ray diagram to measure the distance between the mirror, and the image.
4. Why do we use concave mirrors in car headlights or flashlights?
5. A legend says that Archimedes used mirrors to burn big ships of the enemies. How could Archimedes do that?
6. A concave mirror has the focal length of 20 cm. The distance between the object and the mirror is 50 cm. Draw a ray diagram of the mirror, the object, and the image. Use the ray diagram to measure the distance between the mirror and the image.

ART TIME

Write down an alphabet that you can read in the mirror. Use this alphabet to write a short story. Show your story to parents, teachers, and friends.

TERMINOLOGY

concave – ойыс / вогнутый

focus – фокус / фокус

inverted – төңкерілген / перевернутый

7.4 CONVEX MIRROR

YOU WILL:

- - draw a ray diagram of the image for spherical mirrors and list properties of the image.

QUESTION



Why do objects seem to be smaller in a car side view mirror?

CONVEX MIRROR

Figure 1 -де көрсетілген айна түрлері дөңес айналар деп аталады. Осындай айналар көліктерде және жол айналарында қолданылады.



Figure 1



Figure 1

Оптикалық оське параллель бағытталған сәулелер дөңес айнадан әртүрлі бағытта кері шағылады, Figure 2. Бұл шағылған сәулелерді айна артына интерполяция жасайтын болсақ, барлығы да бір нүктеде түйіседі. Осы нүкте дөңес айнаның фокус нүктесі деп аталады.

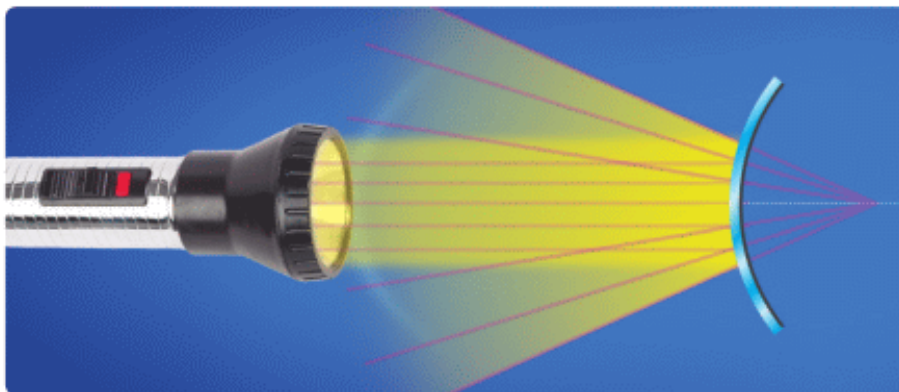

Figure 2

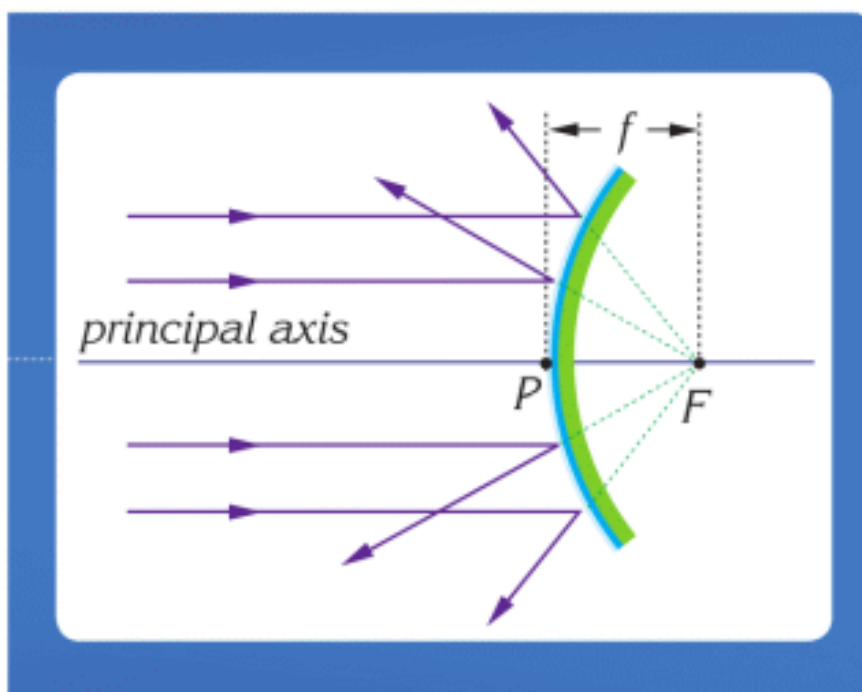
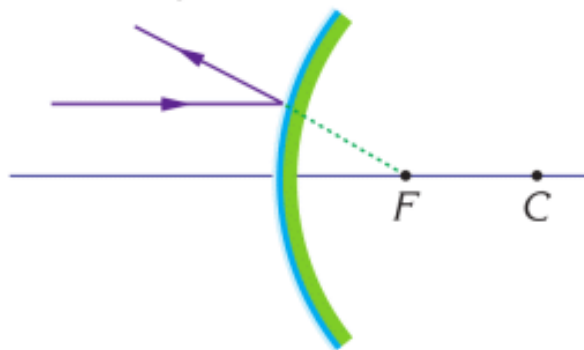

Figure 2

Дөңес айнаға қараған кезде өзіңізді әрдайым кішірейтілген және тура түрде көресіз. Бұл құбылысты түсіну үшін арнайы сәулелерді қарастырайық.

Ондай сәулелердің дөңес айна үшін төрт түрі бар:

- 1 A ray parallel to the principal axis is reflected back so that its extension passes through F.



- 2 When light aims at point F, after reflection it goes parallel to the principal axis.

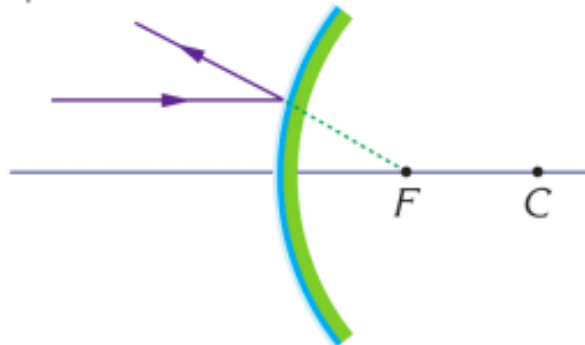

- 3 When light aims at point C, after reflection it goes back over itself.

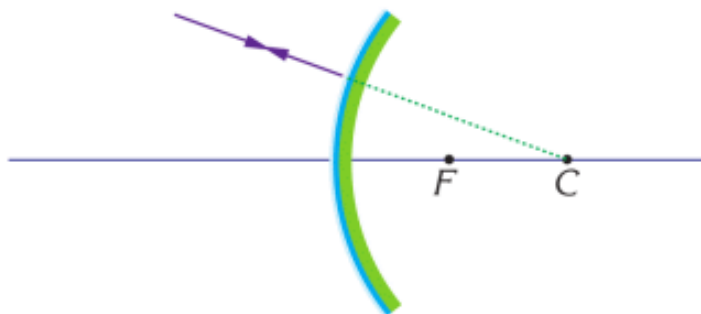

- 4 When light falls on the centre of the mirror, it goes under the same angle.

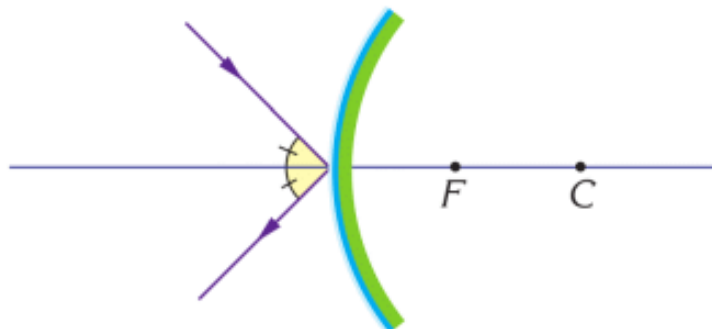
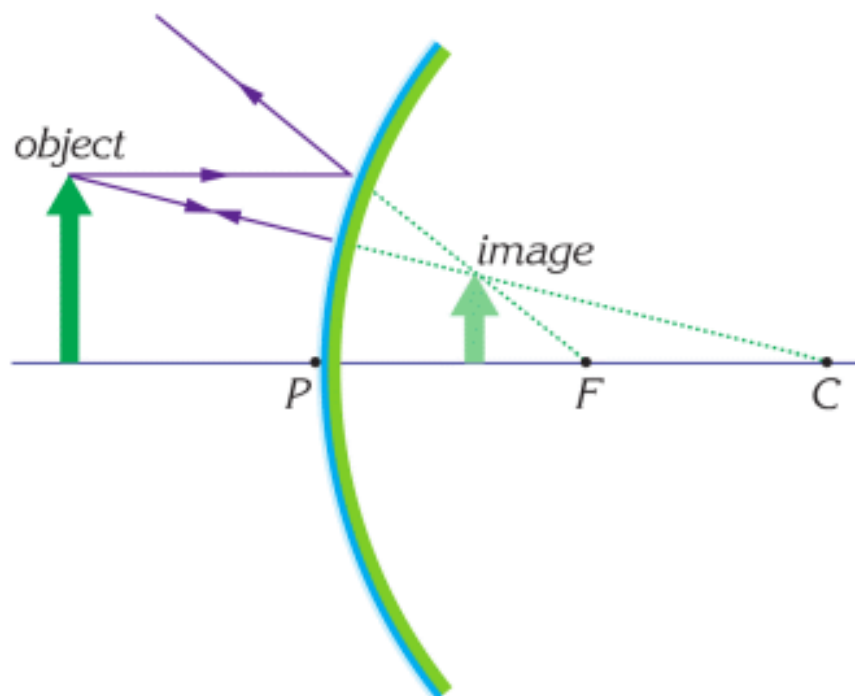

IMAGE FORMATION BY A CONVEX MIRROR

We can use any 2 special rays, to draw the image in a convex mirror.



There is only one type of image. It has these properties:

- a. always between F and P
- b. smaller than the object
- c. virtual
- d. upright

IT-LINK

Use Youtube. Search “Mirror anamorphosis”. Can you draw it?

FACT

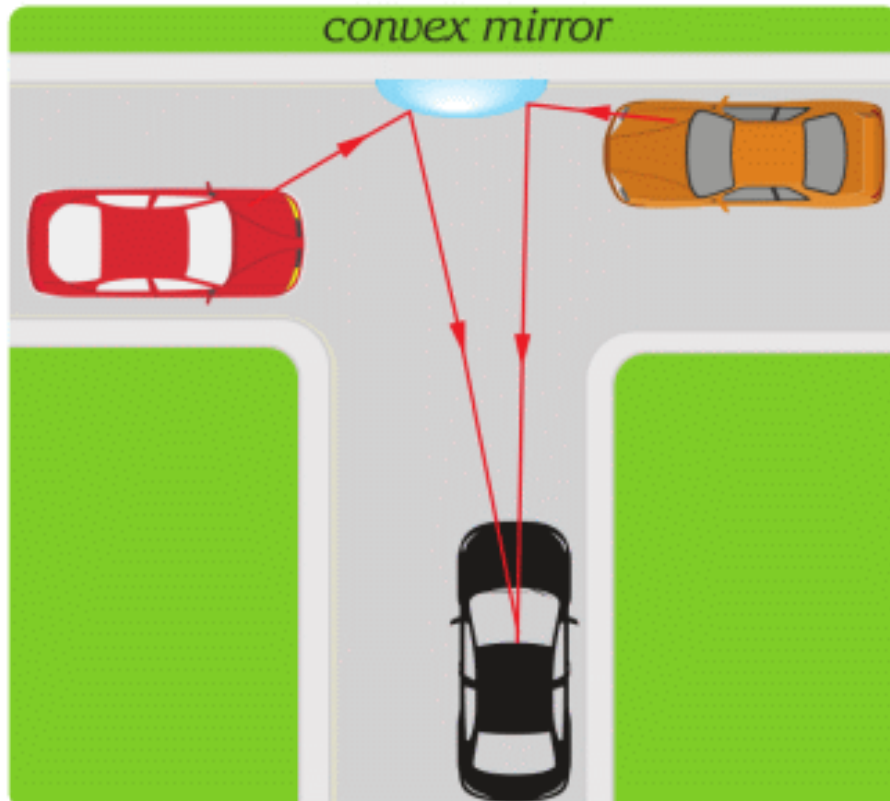

We place convex mirrors on narrow streets to prevent accidents.

EXAMPLE

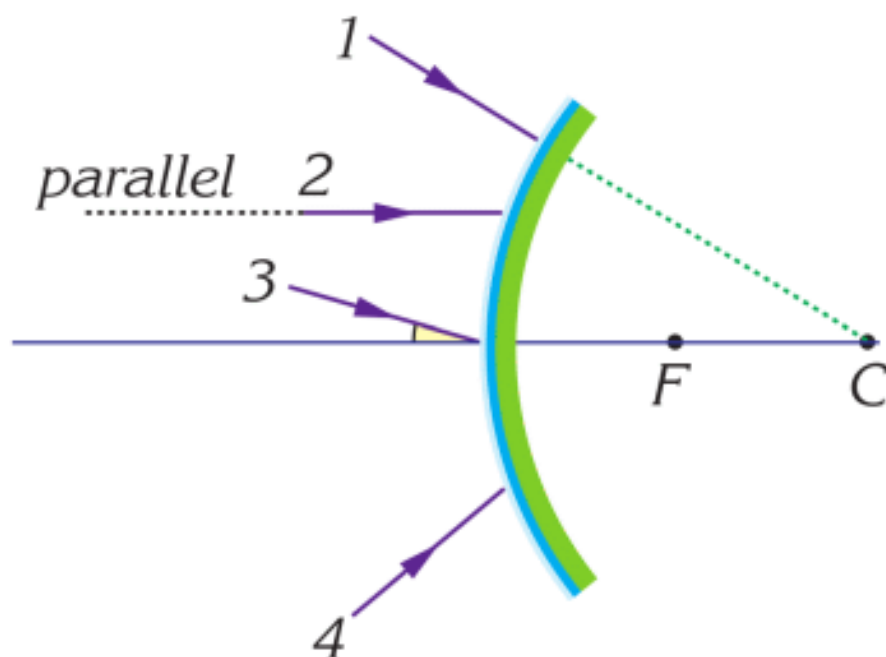

Four light rays are directed towards a convex mirror as shown in the figure. Draw their paths after reflection from the mirror.

Solution:

Using the rules for special light rays we can draw the reflected rays as follows.

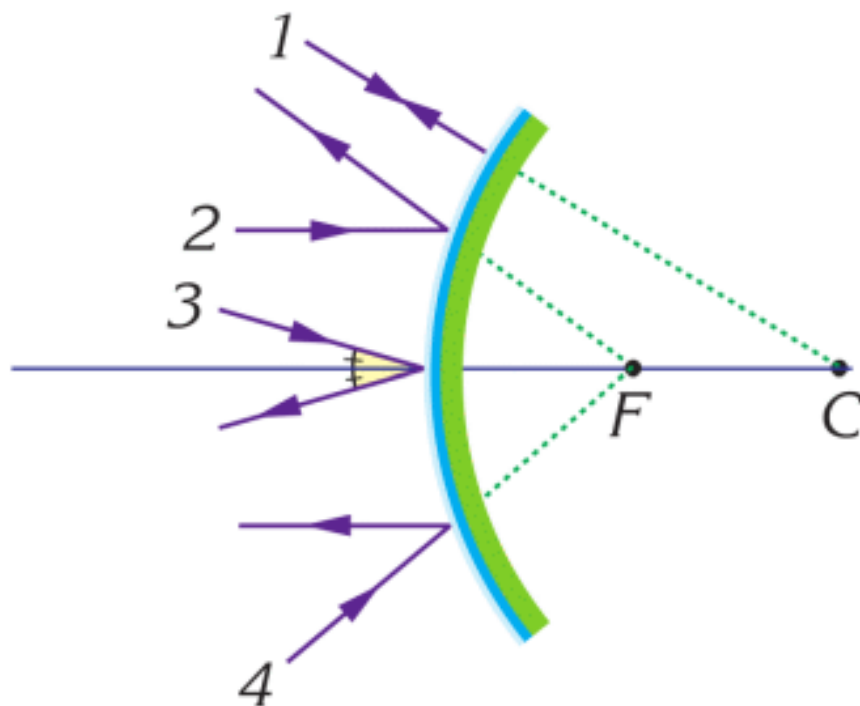

ACTIVITY

A small pencil stands upright in front of a convex mirror. How does its image change when you move pencil closer? Does it get bigger or smaller? Draw a diagram that shows image formation.

LITERACY

1. Why do you appear smaller in a convex mirror? How do rays travel from convex mirror to your eyes?
2. Why do we use convex mirrors in shops (safety mirrors)?
3. Why do cars use convex mirrors in side view mirrors?
4. Which side view mirror is better, convex or plane? Why?
5. How can you draw fields of view of the plane mirror, concave mirror, and convex mirror?

6. A convex mirror has the focal length of 20 cm. the distance between the object and mirror is 10 cm. Draw a ray diagram of the mirror, the object, and the image. Use the ray diagram to measure the distance between the mirror and the image.
7. A convex mirror has the focal length of 20 cm. The distance between the object and the mirror is 50 cm. Draw a ray diagram of the mirror, the object, and the image. Use the ray diagram to measure the distance between the mirror and the image.

ART TIME

Perform a theatre play about the dialogue between “plane mirror, concave mirror, and convex mirror”. What can they talk about? Show it to parents, teachers, and friends.

TERMINOLOGY

convex – дөңес / выпуклый

extension – жалғасы, ұлғаю / продолжение, расширение

7.5 REFRACTION

YOU WILL:

- - apply the law of refraction for problem solving
- - draw a ray diagram in rectangular prism.

QUESTION

Why do objects in water seem to be bigger?

REFRACTION

Жарық сәулесі бір ортадан екінші ортаға өткенде, бастапқы бағытын өзгертеді. Бұл жарықтың сыну құбылысы деп аталады. Figure 1 көрсетілген қарындаш екі ортада тұр: су және ауа. Сол себептен де ол сынық көрінеді.



Figure 1

Жарықтың сыну құбылысы жарықтың бір ортадан екінші ортаға өткенде жылдамдығының өзгеруімен түсіндіріледі.

Мысалы, жарық жылдамдығы:

ауа және вакуумда $300\,000\text{ км/с}$,

шыныда $200\,000\text{ км/с}$,

суда $225\,000\text{ км/с}$ -ке тең.

Жарықтың сынуына ұқсас болып келетін басқа да құбылыс - көліктің мұзды жолға түсуі, Figure 2.

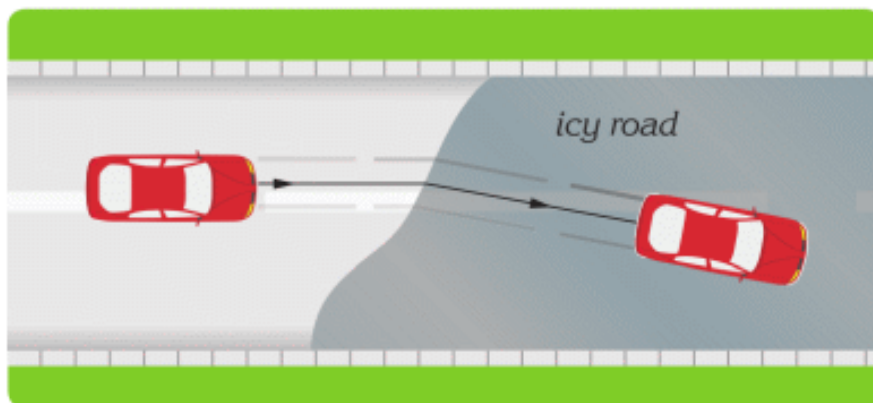

Figure 2

In this topic, we will use n - index of refraction (ratio of speeds).

$$n = \frac{c}{v}$$

c - speed of light in vacuum

v - speed of light in a medium

For example,

$$n_{\text{glass}} = \frac{300\,000 \text{ km/s}}{200\,000 \text{ km/s}} = 1.5$$

$$n_{\text{water}} = \frac{300\,000 \text{ km/s}}{225\,000 \text{ km/s}} \approx 1.3$$

We need an index of refraction to find the path of light rays in different mediums. To do it, we use the law of refraction.

$$n_1 \times \sin i = n_2 \times \sin r$$

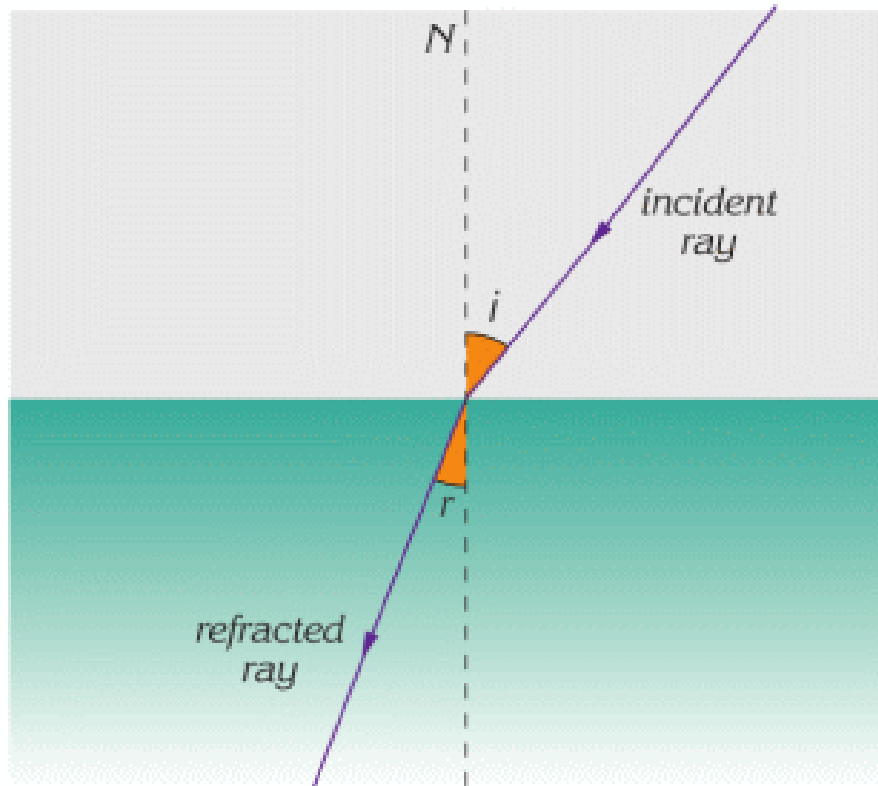

i - angle of incidence

r - angle of refraction

n_1 - index of refraction of first medium

n_2 - index of refraction of second medium

EXAMPLE

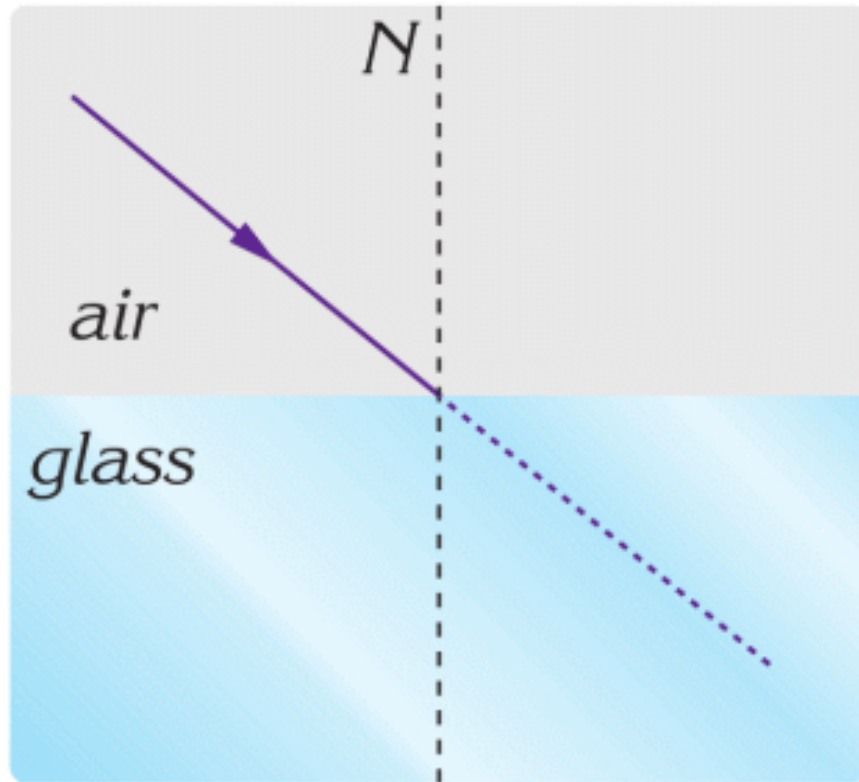

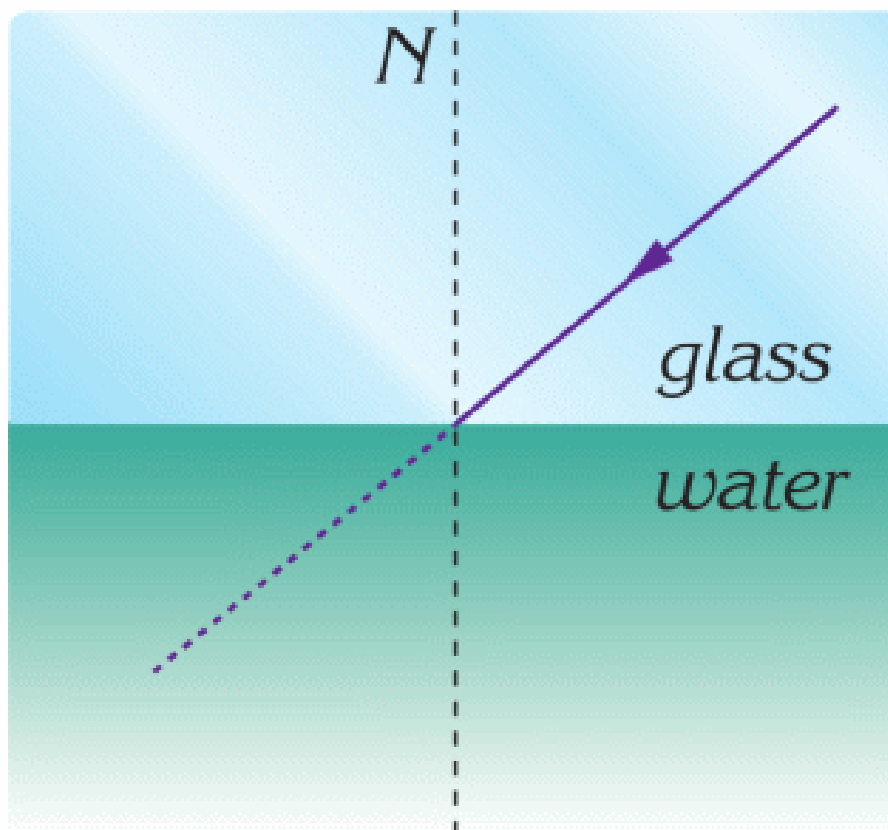

Which path do the light rays follow? Sketch them on the figures. Glass is optically denser than water.

Solution:

Using the laws of refraction, we can draw the path of the rays.

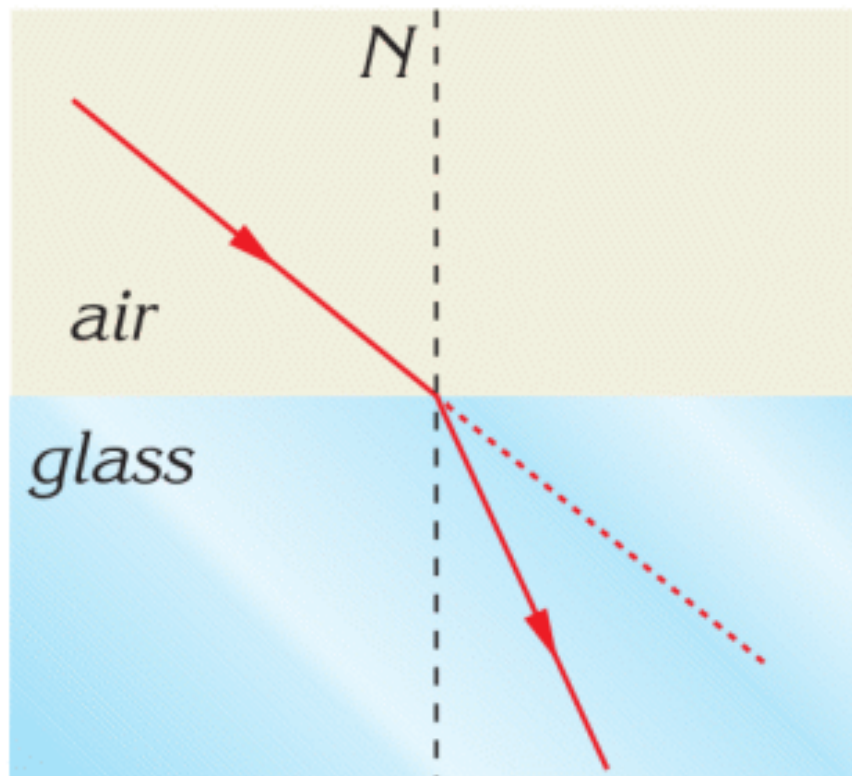

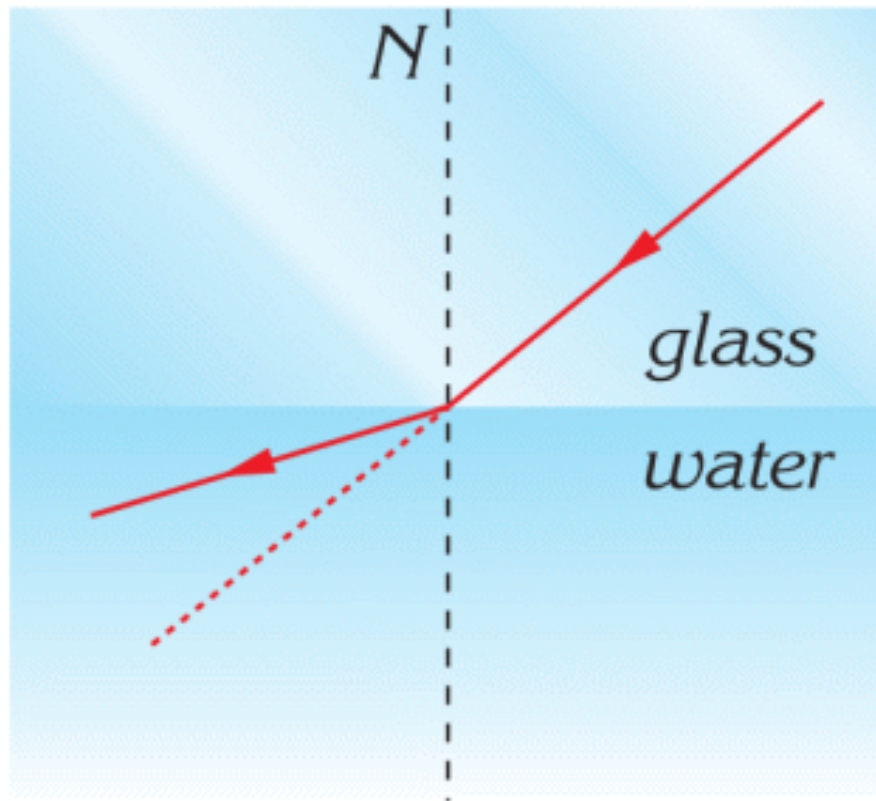

Notice that light bends away from the normal when it passes from glass into water.

FACT

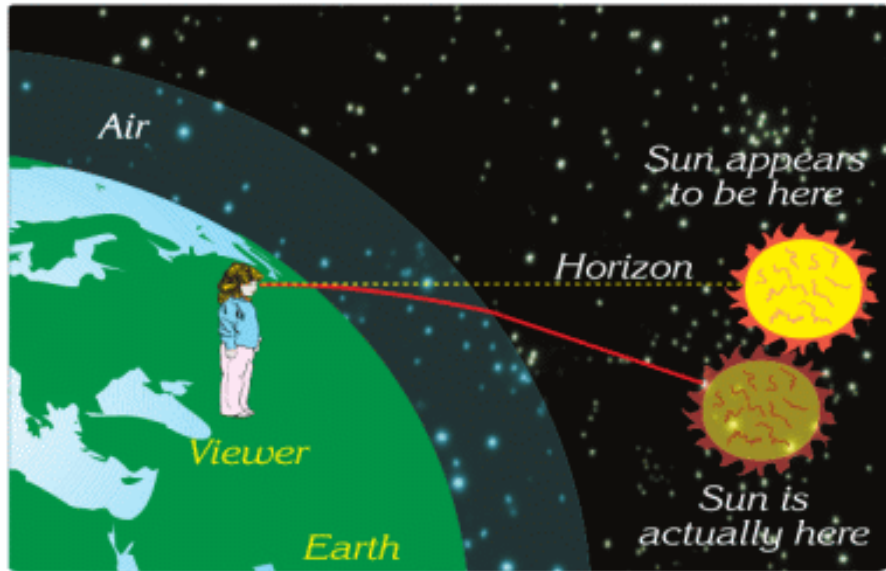

Because of atmospheric refraction, when the Sun is near the horizon, it appears to be higher in the sky.

ACTIVTIY

Glass Block

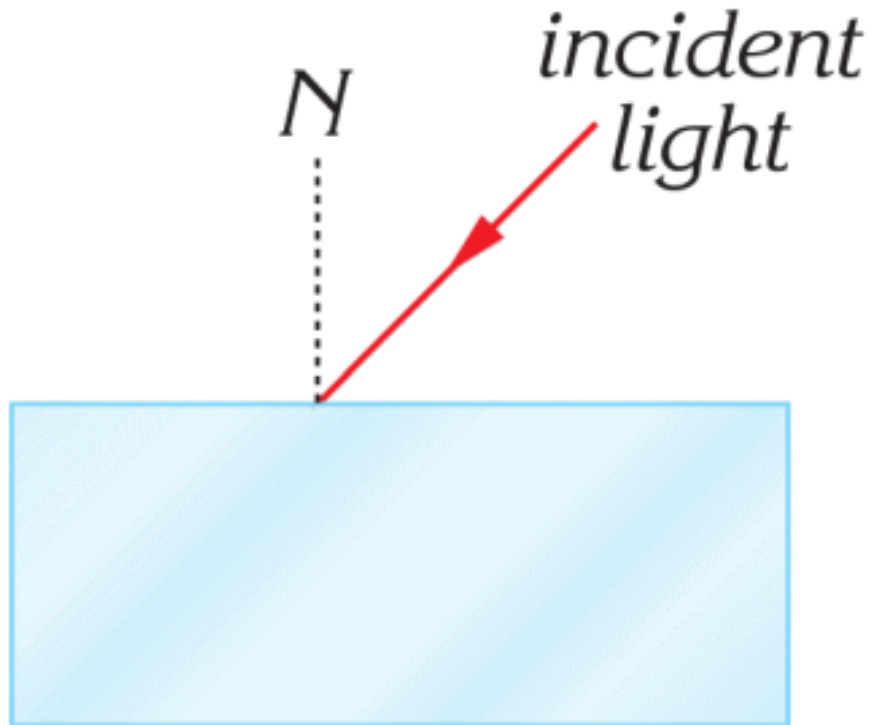

In this activity you will:

- a) apply the law of refraction
- b) draw the path of the ray through the glass block
- c) use different angles of incidence

Task 1

- a. Choose the angle of incidence.
- b. Use the law of refraction to find how ray passes through the block.
- c. Draw the glass block and paths of an incident and refracted rays.

Task 2.

What happens, when you increase your angle of incidence by 10° , 20° , 30° ? Draw another picture of the glass block and paths of rays; use a protractor.

Task 3.

Look at your first picture. Imagine there is no block. How does the ray travel in this case? What is the difference?

RESEARCH TIME

a) Place the coin into the cup.

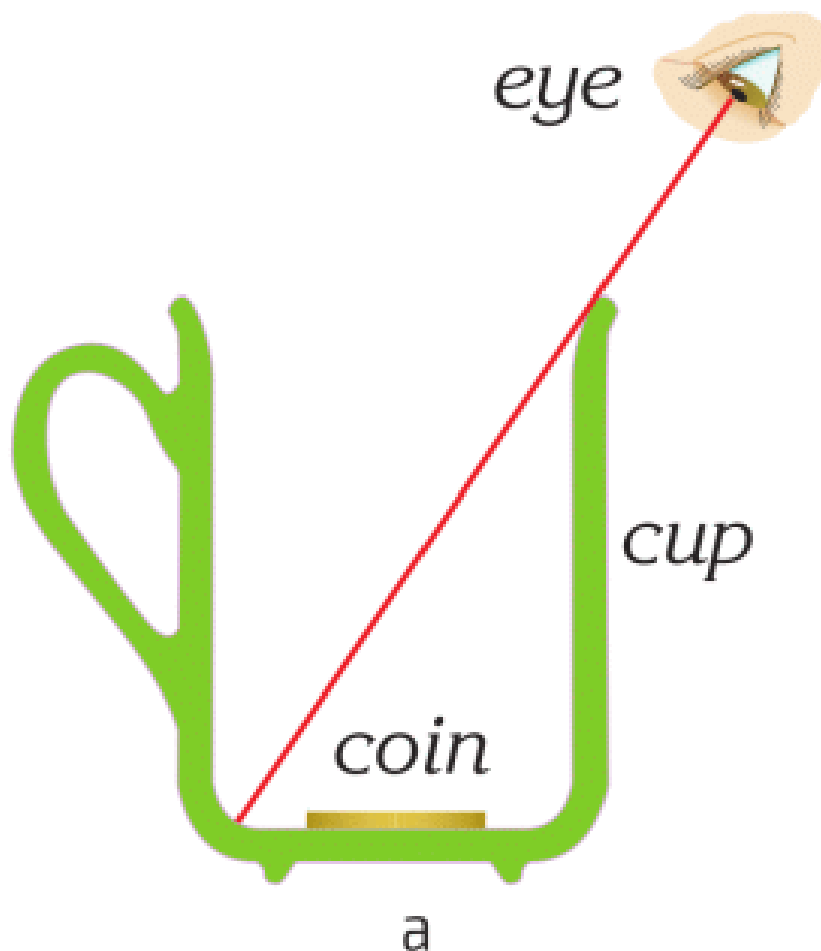

b) Move your head until you do not see the coin (figure a).

*keep your
head still* 



b

Do not move the head and fill the cup with water (figure b).
Do you see the coin now? Why?

LITERACY

1. You are looking at the fish in water. Can you draw a light ray from the fish to your eye?

2. Rainbow forms because of refraction. What mediums do cause this refraction? How can you draw this refraction?
3. Why does the rainbow have all colours?
4. You send a laser ray into the water. The angle of the incidence in the air is 60° . What is the angle of refraction in water? Index of refraction of water is 1.33. Index of refraction of air is 1.
5. Following the path of the light rays, name the mediums in the figures.

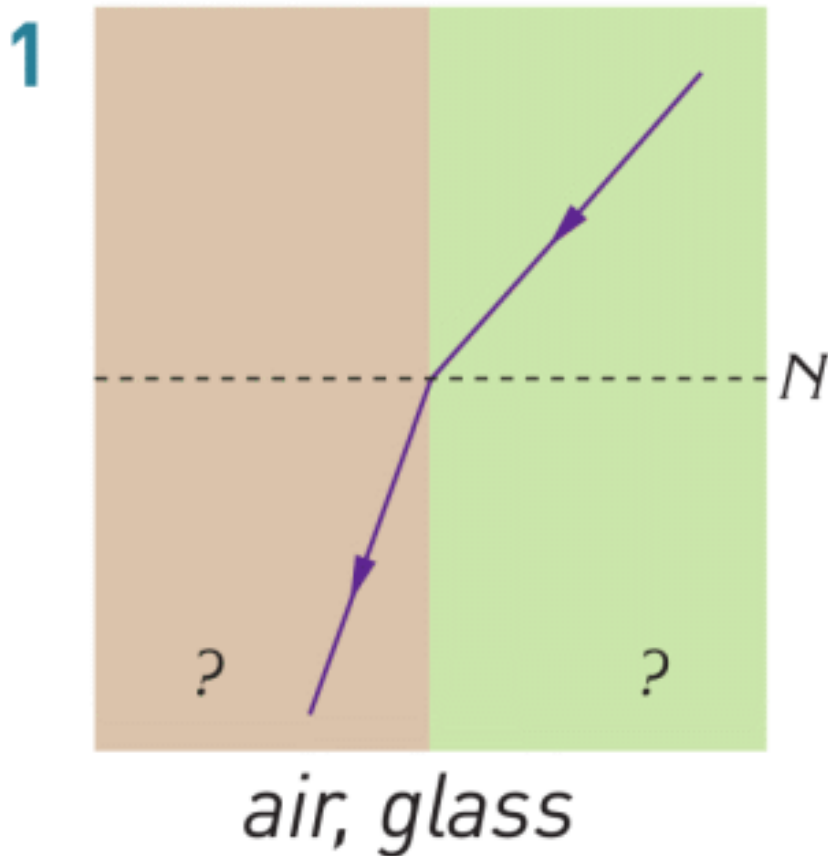

2

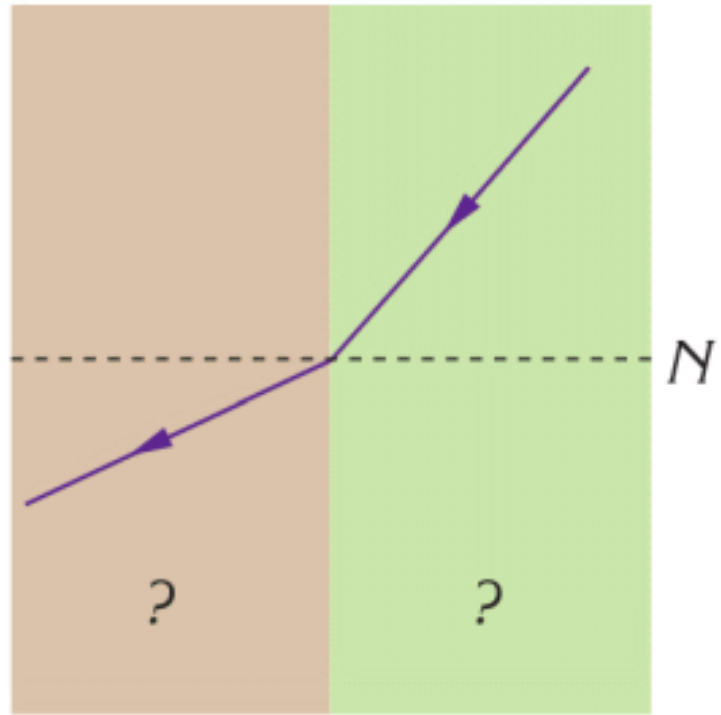

air, water

3

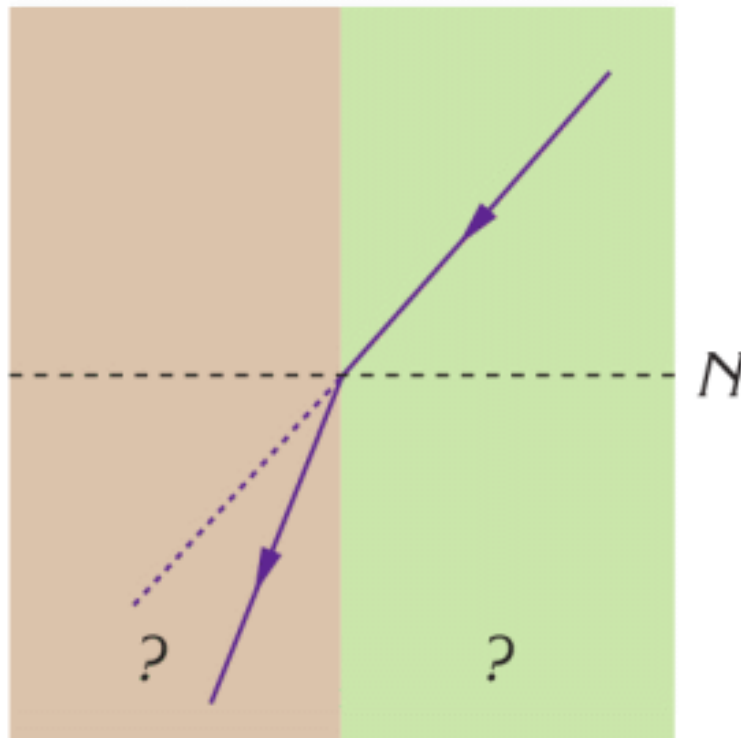

glass, water

ART TIME

Perform dance about “refraction”. What moves can you use?
Show dance to parents, teachers, and friends.

TERMINOLOGY

refraction – сыну / преломление

medium – орта / среда

index of refraction – сыну коэффициенті / коэффициент преломления

7.6 TOTAL INTERNAL REFLECTION

YOU WILL:

- - explain total internal reflection using experiment.

QUESTION







Why do people use endoscopes? How does an endoscope work?

What materials are used to make the endoscope?

TOTAL INTERNAL REFLECTION

Sometimes a light cannot pass from the medium with higher index of refraction into the medium with lower index of refraction. Instead, it travels along the surface. When the angle of refraction is 90° , the angle of the incidence is called the critical angle, ray 3 in the figure below.

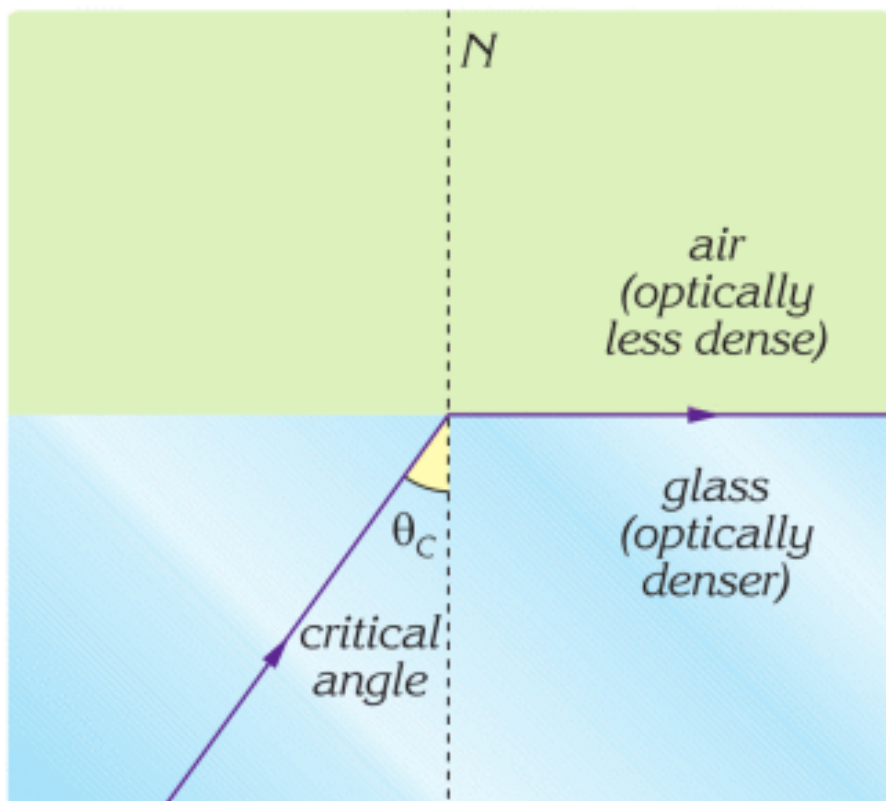

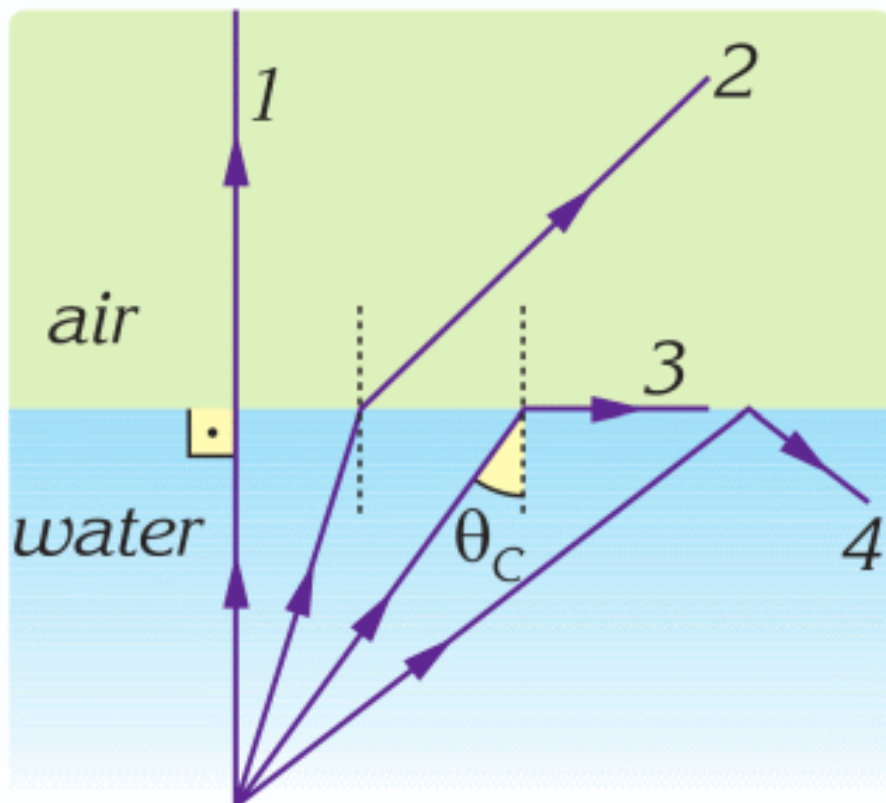

If the angle is greater than the critical angle, the light cannot pass through the other medium. The light ray reflects back (ray 4). This phenomenon is called total internal reflection.

Total internal reflection can be observed in glass prisms. The light ray in the glass prism cannot go into the air. The angle of the incidence of ray is 45° . This angle is greater than the critical angle for glass (42°). As a result, total internal reflection is observed. The ray changes direction by 90° , Figure 1.

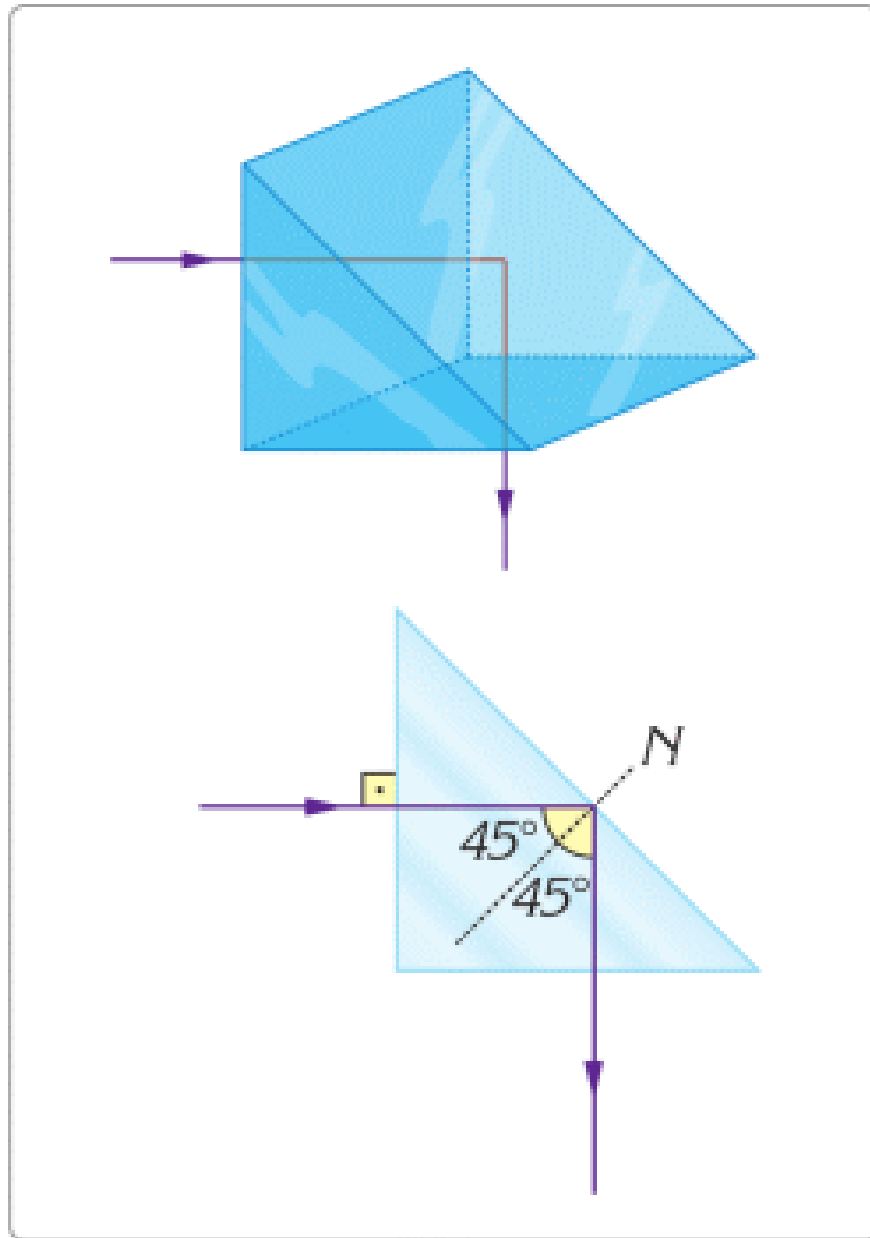

Figure 1

OPTICAL FIBRE

Оптикалық талшықтар толық ішкі шағылу арқылы жарық (сәуле) тасымалдайды. Осындай кабельдер жоғары

жылдамдықты интернет үшін қолданылады. Figure 2-де қызыл сәуленің іштен шағылу мысалы көрсетілген.

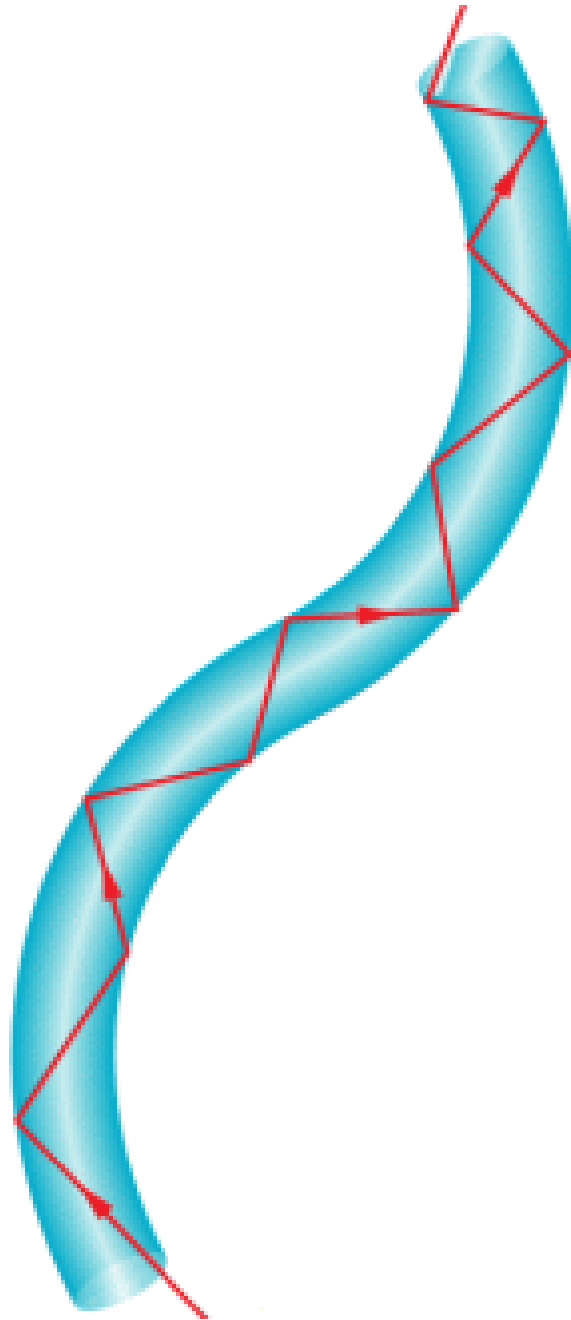

Figure 2



Optical fibre cables are used in high-speed Internet cables. Optical fibre cables can transfer thousands times more information than copper cables.

EXAMPLE

Draw the paths of the light rays incident on the prisms.

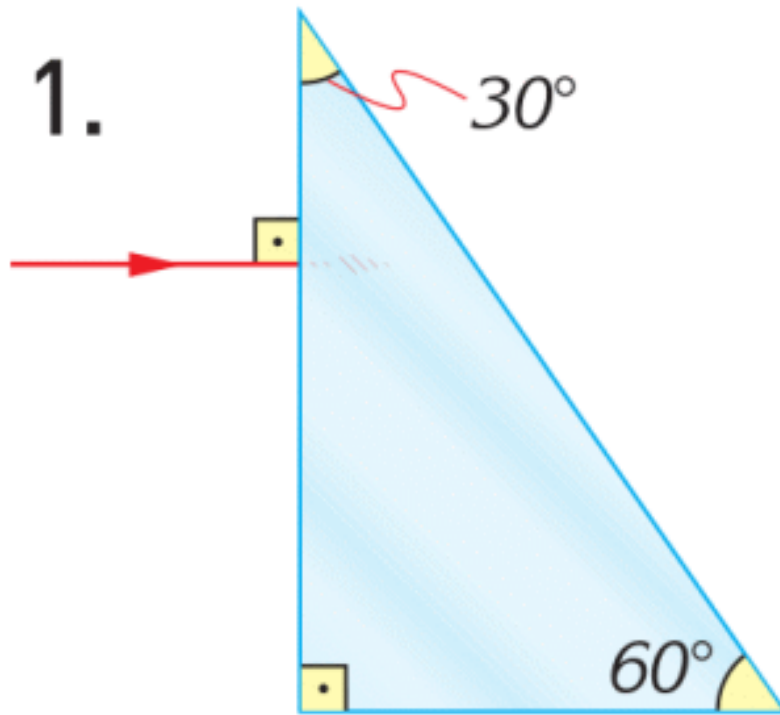

2.

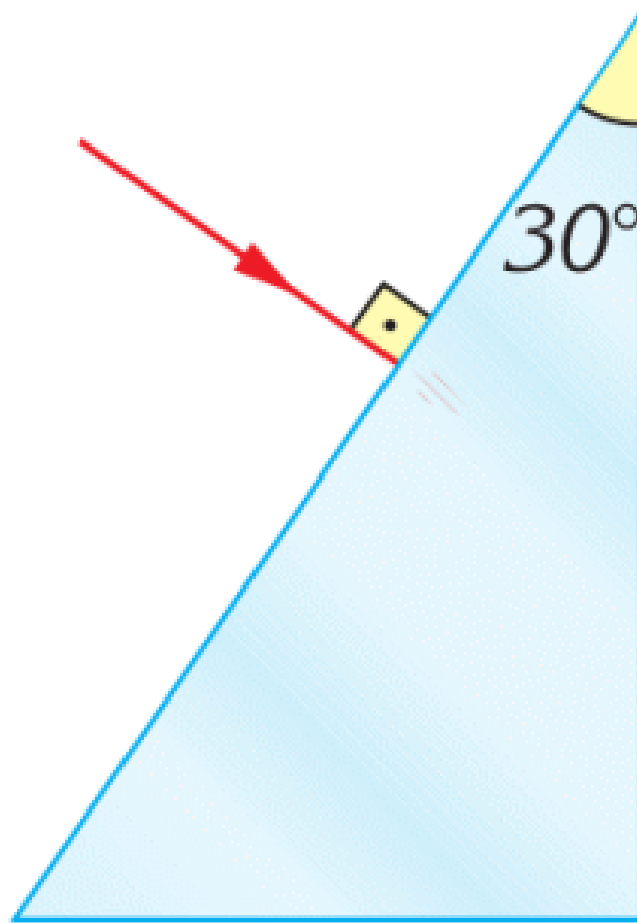

Solution:

1. Ray strikes the second surface with an incident angle of 30° . It is smaller than 42° , so ray passes into the air.

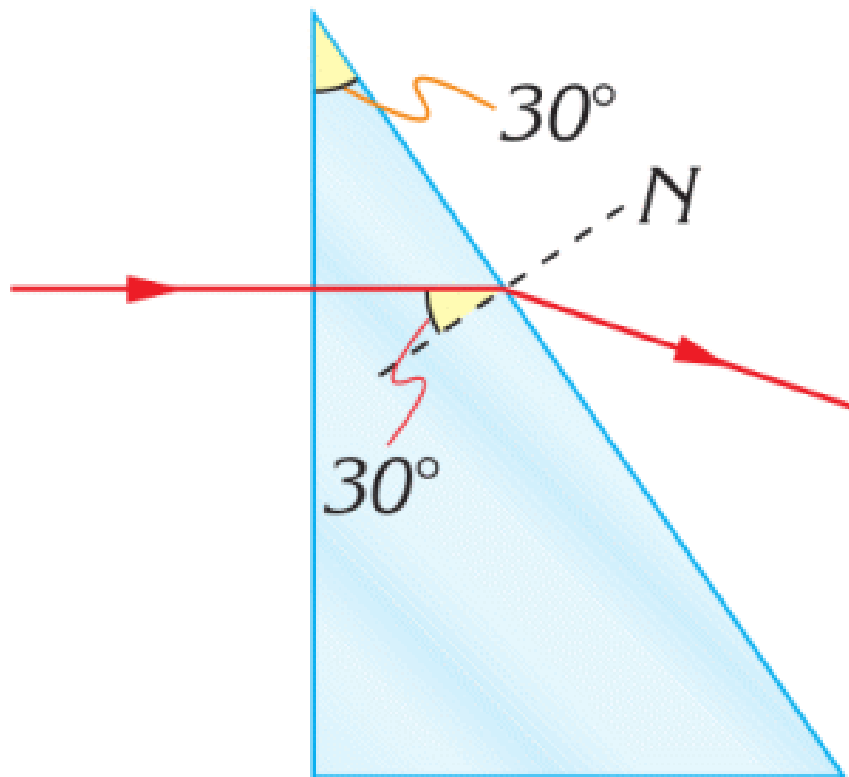

2. Ray strikes the surface with an angle of incidence of 30° . The ray passes into air bending away from the normal, towards the base of the prism.

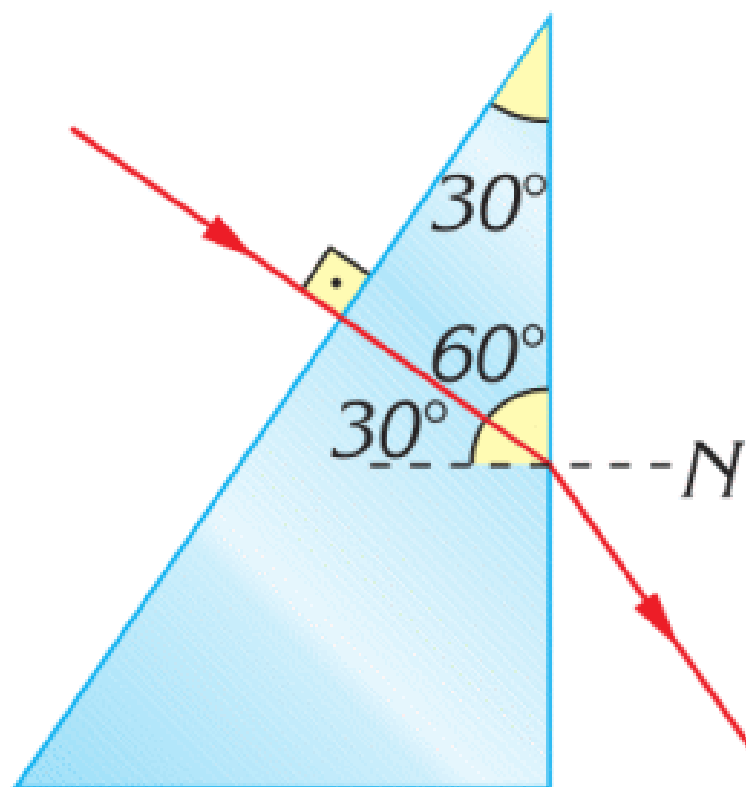

RESEARCH TIME

Area of use of optical fibers	Why and how are optical fibers used?	Who does use them?
Communication		
Temperature sensors		
Medicine		
Lasers		

Fill this table

RESEARCH TIME

Materials: Laser pointer, Plastic bottle, Water, Scissors, Small bathtub, Dark room.

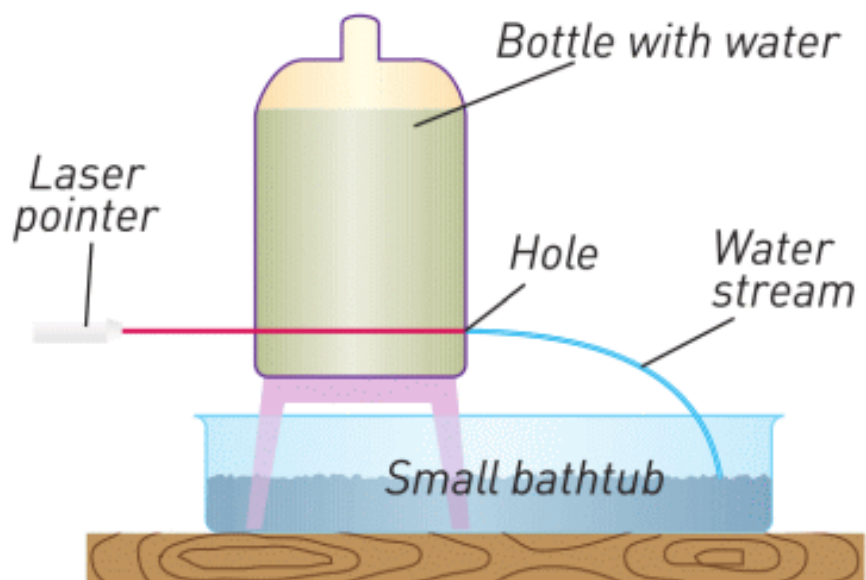

Procedure: Make a setup as on the picture. Direct laser ray into the hole. Look at the stream. What can you see? Why does it happen?

RESEARCH TIME

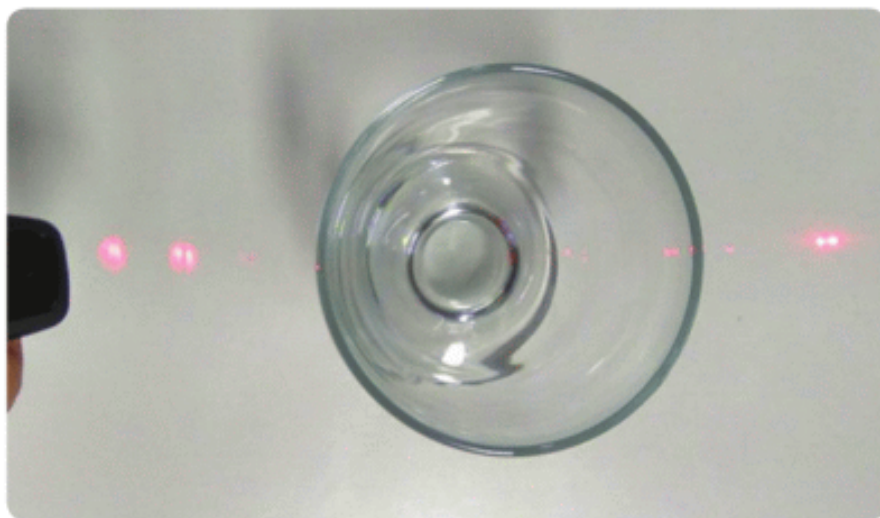

Point a laser to the glass. Why is the laser ray reflected even if the glass is transparent?

FACT

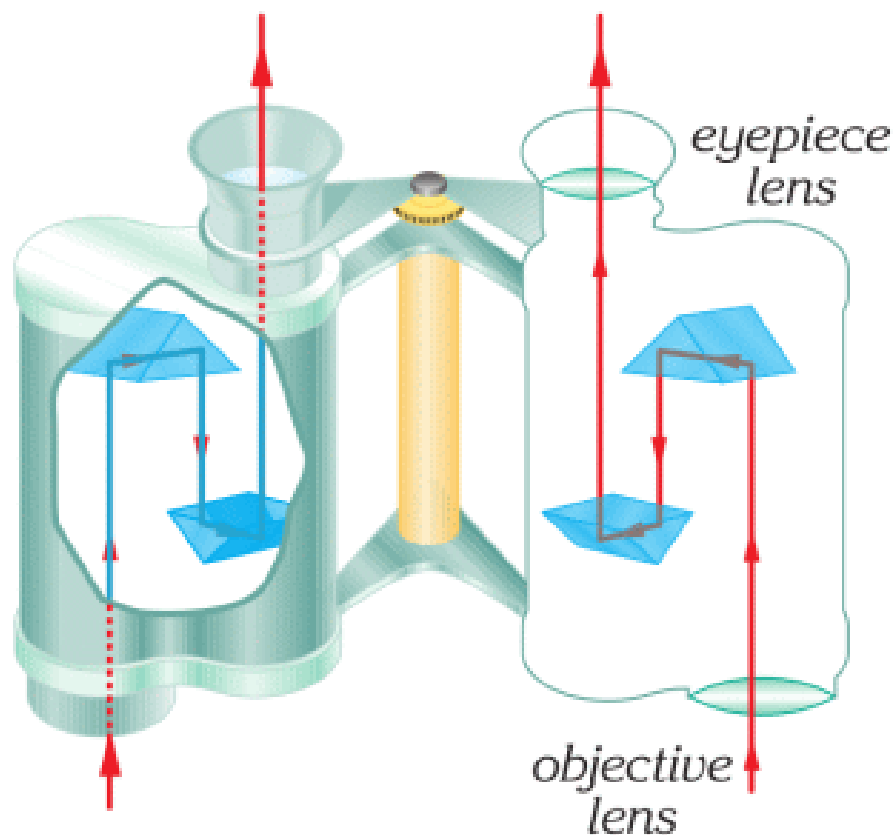

Binoculars have converging lenses and prisms. Prisms use total internal reflection to turn the inverted image upright.

LITERACY

1. You send a laser ray from water. Angle of incidence in the water is 60° . Draw the ray diagram of laser, water, air.

Index of refraction of water is 1.33. Index of refraction of air is 1.

2. Why are diamonds very bright? Why is glass not bright?
3. Water has no colour, water is transparent. Why do “light fountains” have colour?



4. In the figure, you can see laser and glass prism. Determine the angle between the incident ray and the refracted ray. Also determine the angle of incidence. Is angle of incidence greater than critical angle for glass? Use a protractor.

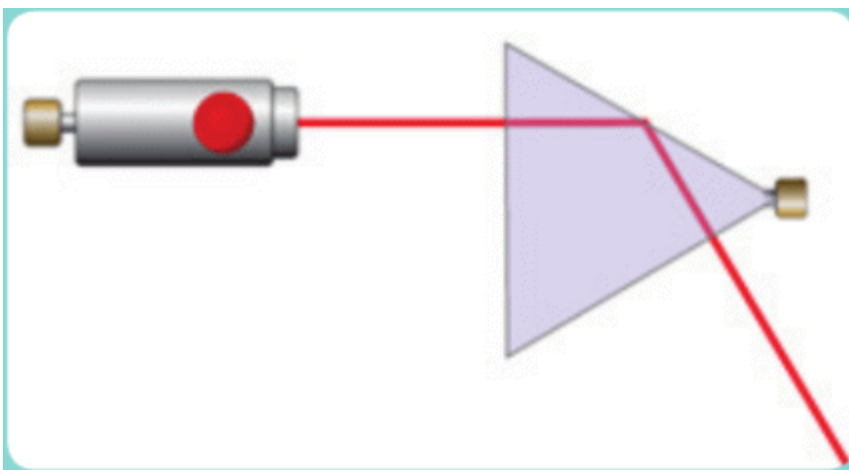

ART TIME

Imagine yourself as a signal that travels in an optical internet cable. Imagine feelings and thoughts of this signal. Write a short story about this signal and read it to parents, teachers, and friends.

TERMINOLOGY

endoscope - эндоскоп / эндоскоп

critical angle - критикалық бұрыш / критический угол

7.7 CONVERGING LENS

YOU WILL:

- - apply the formula of a thin lens for problem solving;
- - apply the formula of a magnification of lens for problem solving;
- - draw a ray diagram of the image in a thin lens and list properties of the image.

QUESTION



Why does the boy's eye seem bigger?

CONVERGING LENS

A converging lens is thicker at the centre. Converging lenses collect rays which are parallel to the principal axis in one

point. This point is called a focal point. A distance between the lens and the focal point is called focal length. Symbol “F” denotes the focal length.

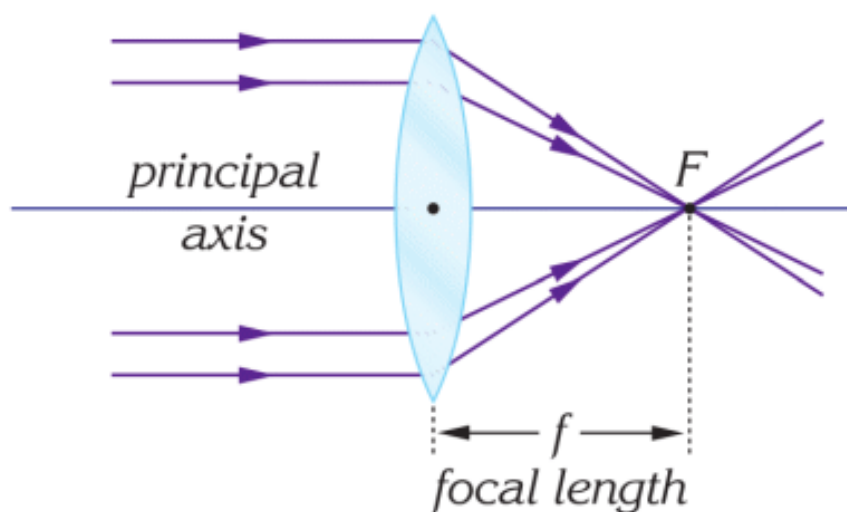
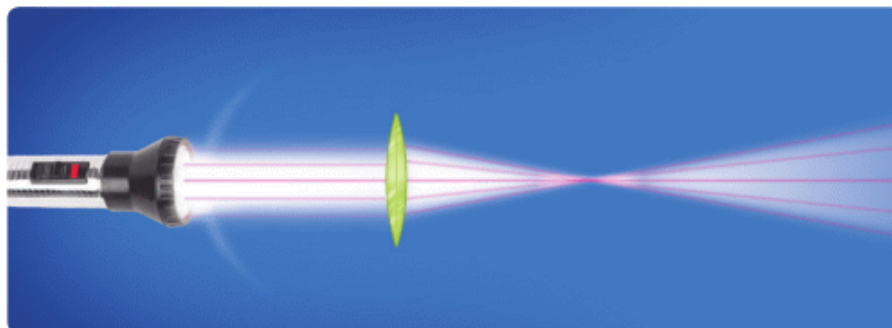

There are three special rays for converging lenses. We use them to draw an image. You can see them below.

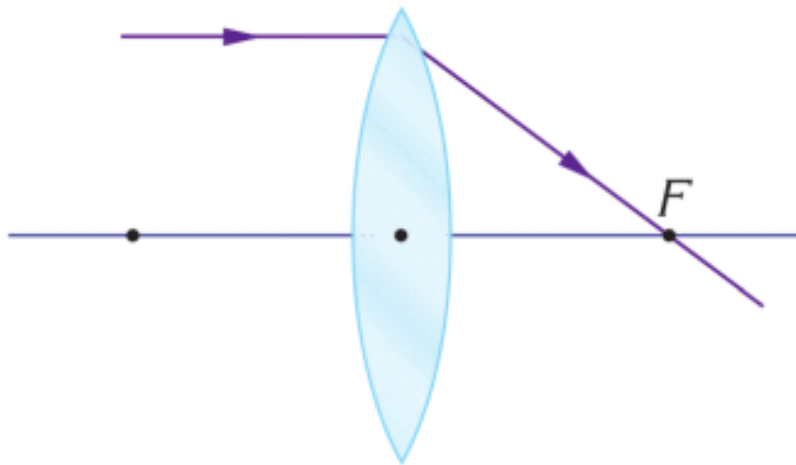

Special ray 1

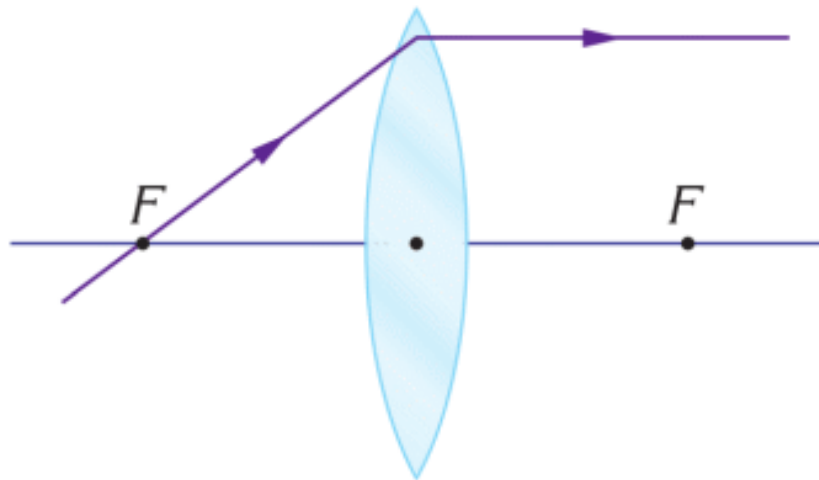

Special ray 2

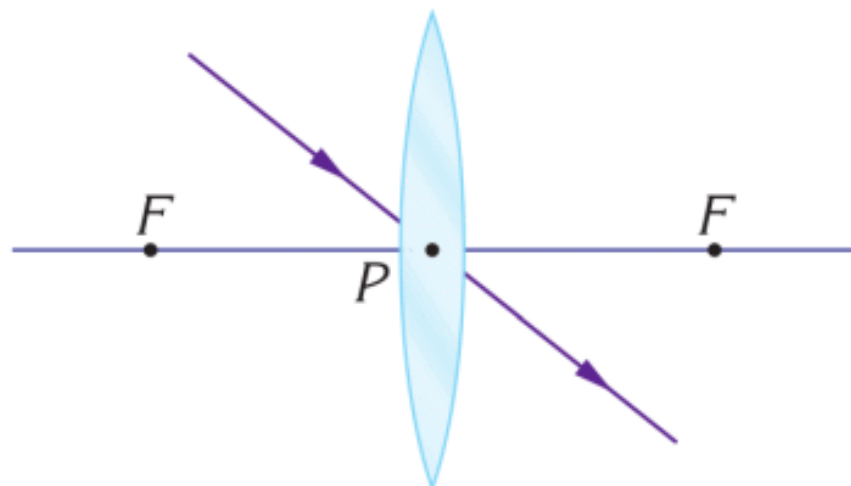

Special ray 3

IMAGE FORMATION BY A CONVERGING LENS

Бірінші жағдайда дене линзадан алыс орнатылады, Figure 1. Дененің ұшынан линзаға қарай екі сәуле жібереміз. Біріншісі жазықтыққа параллель, ал екіншісі линзаның ортасынан өтеді. Сәулелердің қиылысқан жері кескіннің басы болып табылады. Special ray 1 және Special ray 2 суреттерін қараңыз.

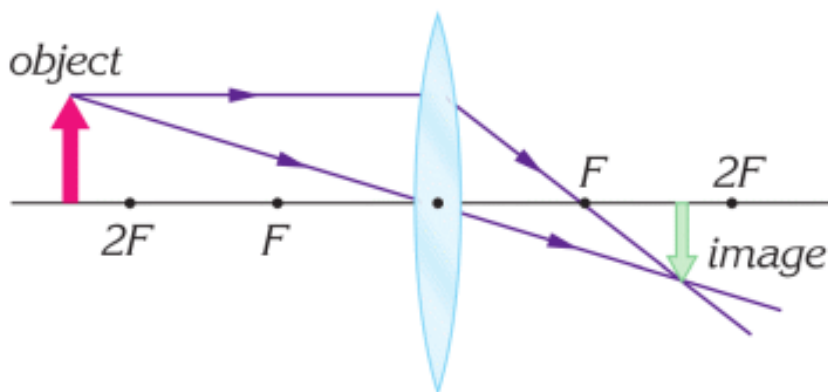

Figure 1

Екінші жағдайда дене линзаға жақын орнатылады, Figure 2.

Объектінің ұшынан линзаға қарай екі сәуле жібереміз. Біріншісі жазықтыққа параллель, Special ray 1, ал екіншісі линзаның ортасынан өтеді, Special ray 3. Нәтижесінде, сәулелердің қиылыспағанын байқайсыз. Осындай жағдайда кескін сынған сәулелердің жорамал жалғасулардың қиылысуы арқылы алынады. Кескін үлкейтілген және жорамал болады.

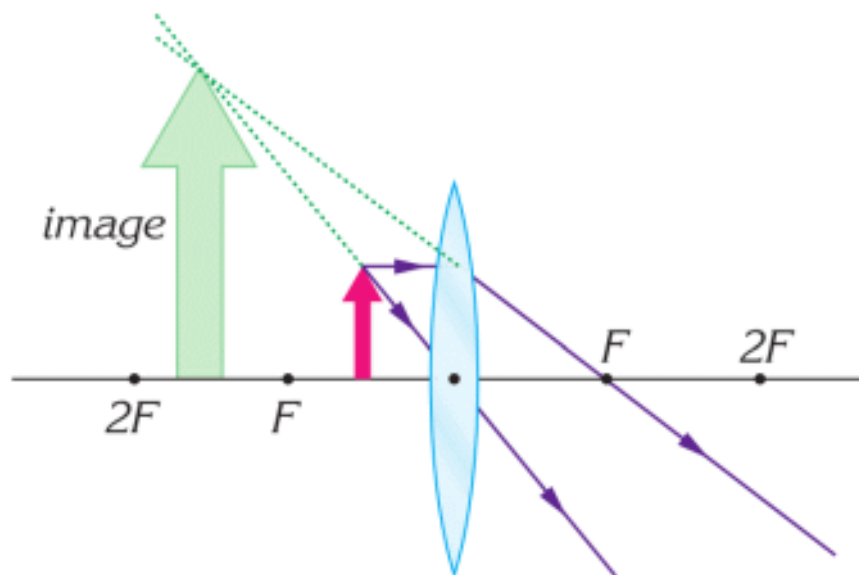

Figure 2

The image here is bigger (not smaller), upright (not inverted), virtual (not real). The image is virtual because rays do not intersect.

THE FORMULA OF THE LENS

$$\frac{1}{F} = \frac{1}{d} + \frac{1}{f}$$

F: focal length of a lens (meters)

d: distance between the lens and the object (meters)

f: distance between the lens and the image (meters)

The distance d is always positive. However, the distance f can be both negative and positive. If the image is real, then f is positive. If the image is virtual, then f is negative.

MAGNIFICATION OF IMAGE

The converging lens produces an image that can be bigger or smaller than an object. Magnification shows how many times the image is greater or smaller than the object.

$$M = \frac{-f}{d} = \frac{H}{h}$$

M: magnification of the lens

d : distance between the lens and the object (meters)

f : distance between the lens and the image (meters)

h : height of the object (meters)

H : height of the image (meters)

If $M < 0$, the image is inverted.

If $M > 0$, the image is upright.

EXAMPLE

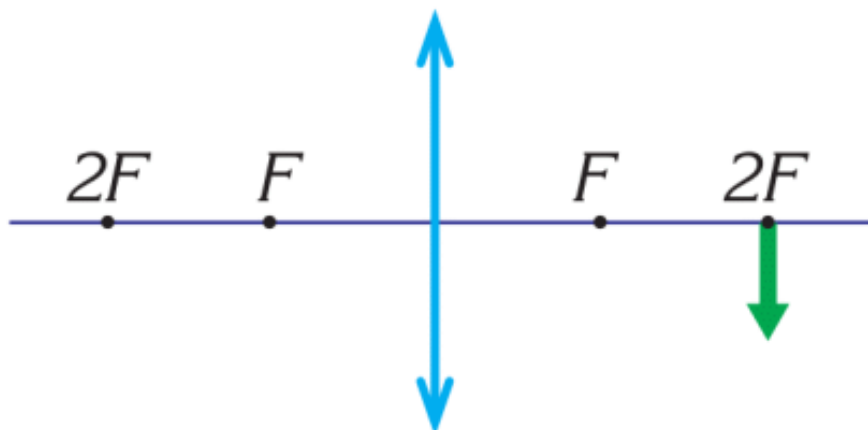

An object is at a distance of 0.2 m from the converging lens. The focal length of the lens is 0.1 m.

- Where is the image? Draw the image and find the distance of the image. Use a ruler.
- Determine magnification. Use the ruler.
- List the image properties.

Solution:

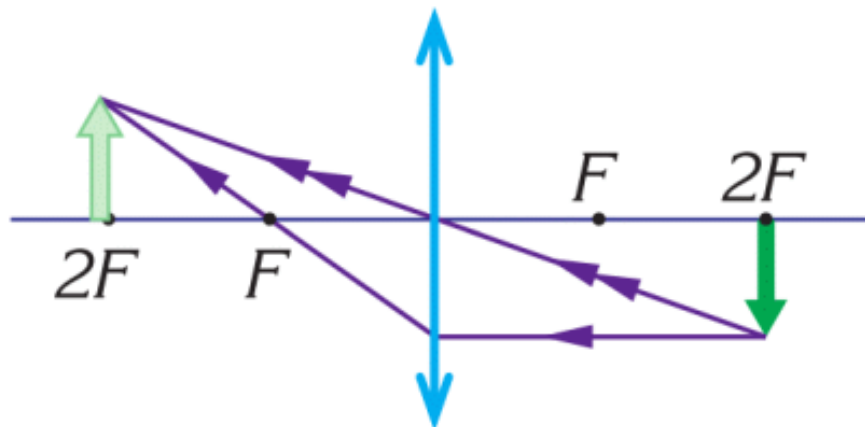

a. $\frac{1}{F} = \frac{1}{d} + \frac{1}{f}; \quad \frac{1}{0.1} = \frac{1}{0.2} + \frac{1}{f}; \quad f = 0.2\text{m};$

b. $M = \frac{-f}{d}; \quad M = \frac{-0.2}{0.2} = -1$

c. The image is real, inverted, and has the same size as the object.

FACT

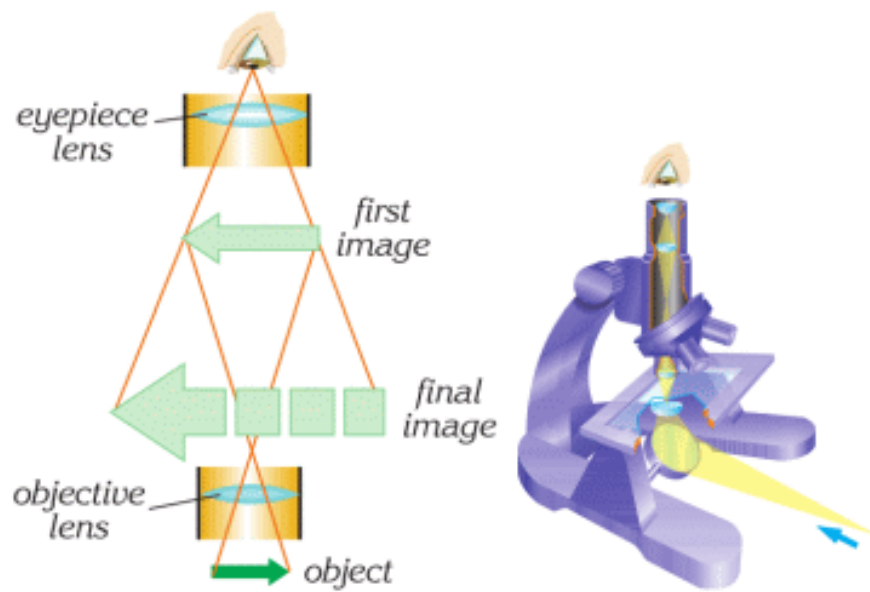

A microscope uses two converging lenses. Microscope makes bigger images of small objects, Figure.

RESEARCH TIME

Materials: A small box, tracing paper, tape, nail, converging lens.

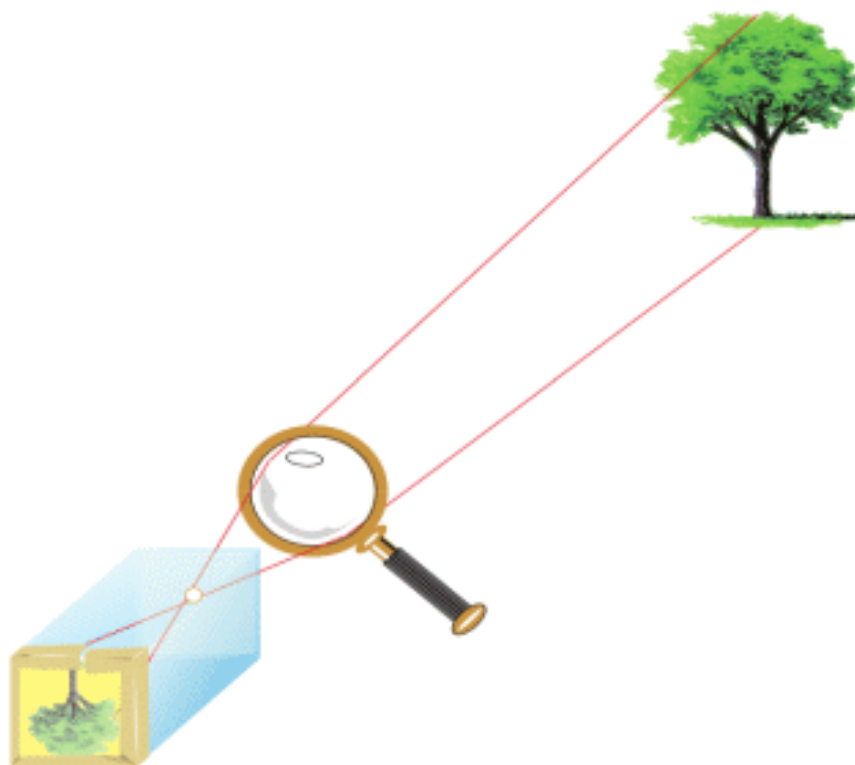

Procedure: Make a hole in the box with a nail, as shown in the Figure. Cover one end of the box with the tracing paper. Now make an image of something, as shown in the Figure.

LITERACY

1. Why is the image magnified in a converging lens? How do rays travel through the converging lens to your eyes?
2. At what distance should the magnifying glass be placed so you can see words twice bigger? The magnifying glass has a focal length of 25 cm.
3. How can you make a telescope with two converging lenses? How do rays travel in this telescope? Draw a ray diagram of the telescope.
4. The distance between the lens and the object is 8 cm. The focal length of the lens is 20 cm. Draw image of the

object. List its properties. Determine magnification.

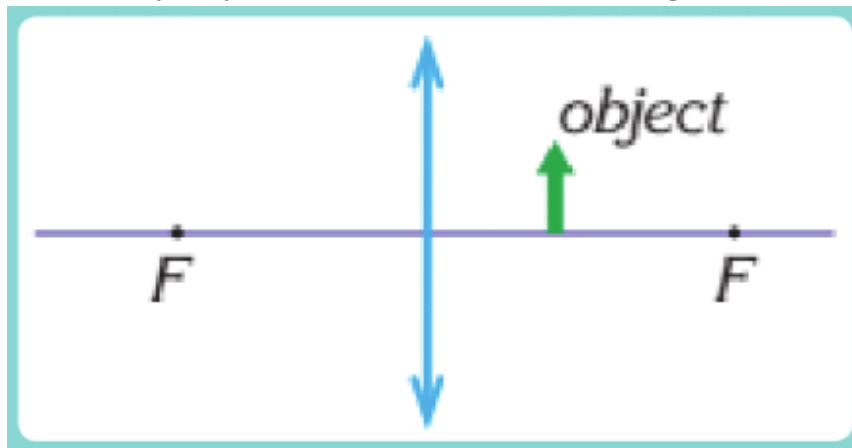

ART TIME

Change smartphone to a microscope. What materials can you use? What magnifications can you achieve? Make a microscope from a smartphone and show to parents, teachers, and friends.

TERMINOLOGY

converging lens – жинағыш линза / собирающая линза

telescope – телескоп / телескоп

magnification – ұлғайту / увеличение

7.8 DIVERGING LENS

YOU WILL:

- - apply the formula of a thin lens for problem solving;
- - draw a ray diagram of the image in a thin lens and list properties of the image.

QUESTION



Why do objects seem smaller in eyeglasses?

DIVERGING LENS

Шашыратқыш линзаның ортасы шеттеріне қарағанда жіңішке келеді. Параллель жіберілген сәулелер линзадан өткенде бір нүктеден шашырағандай болып көрінеді. Осы нүкте шашыратқыш линзаның фокусы болып табылады.

Фокус пен линзаның ортасына дейінгі қашықтық фокустық қашықтық (F) деп аталады, Figure 1.

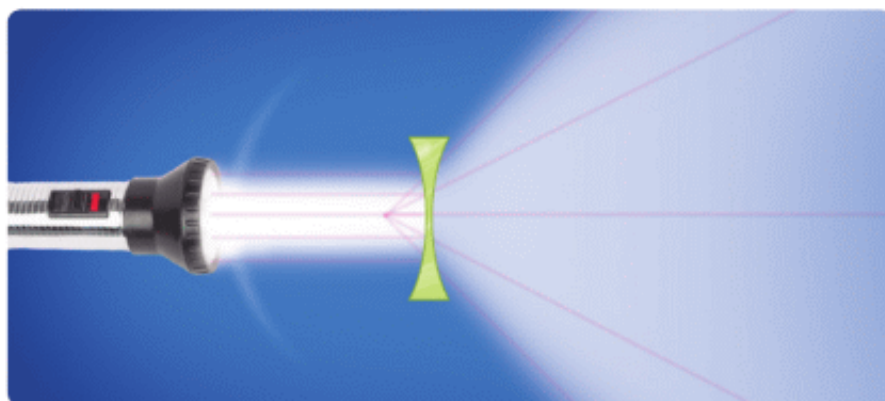

Figure 1

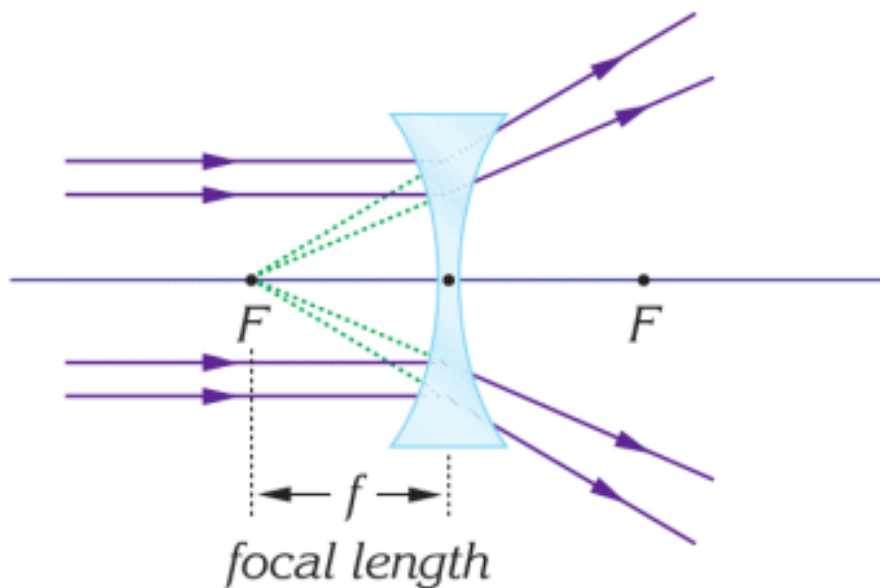
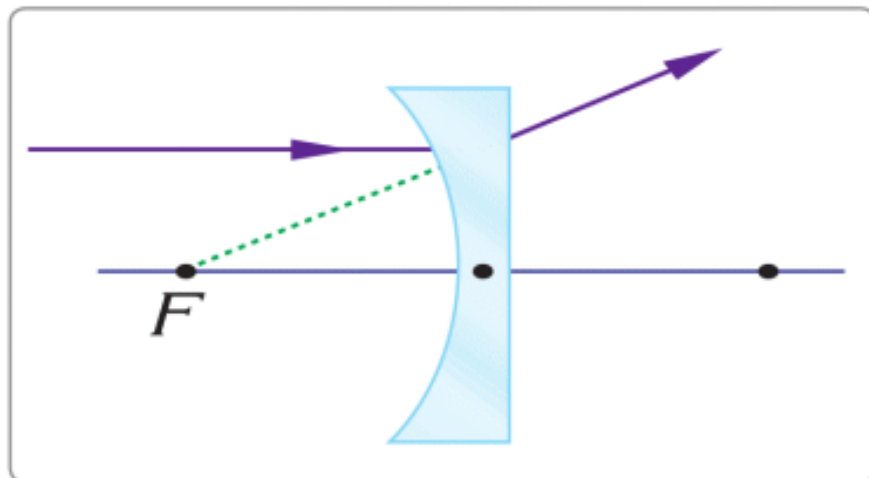
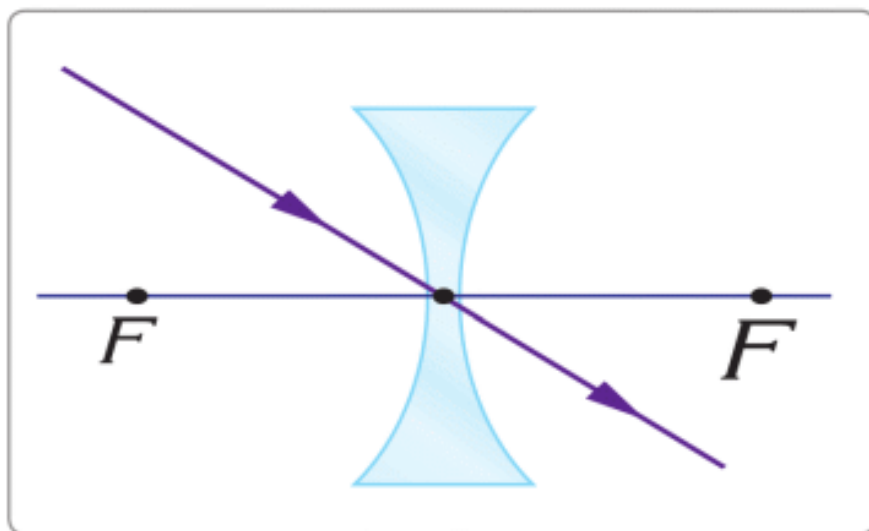

Figure 1

Кескін орнату үшін үш арнайы сәуле қолданамыз. Оларды Special ray 1,2,3 суреттерінде көре аласыз.



Special ray 1



Special ray 2

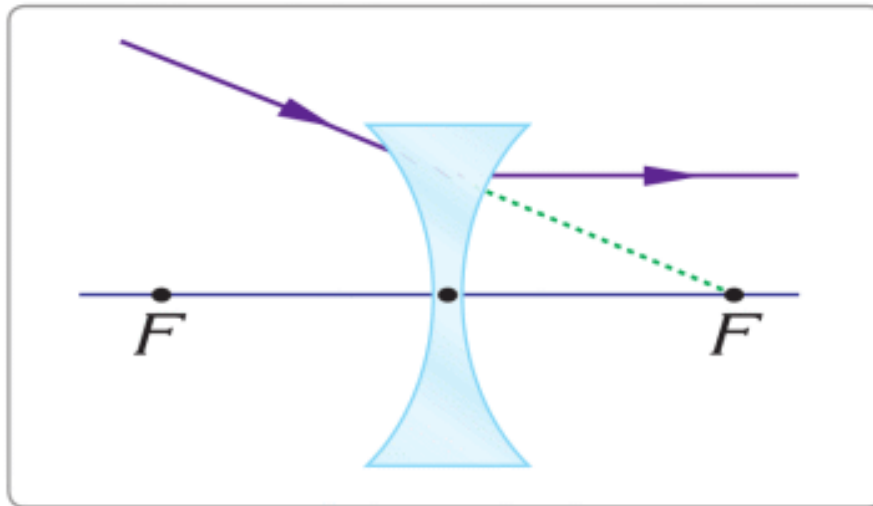

Special ray 3

IMAGE FORMATION BY A DIVERGING LENS

To form the image, we send two rays from the head of the arrow. The first ray is parallel to the principal axis (use Special ray 1). The second ray goes through centre of the lens (use Special ray 2). Rays do not intersect.

That is why we use extensions of rays. The intersection of extensions of rays is the head of the image, Figure 2.

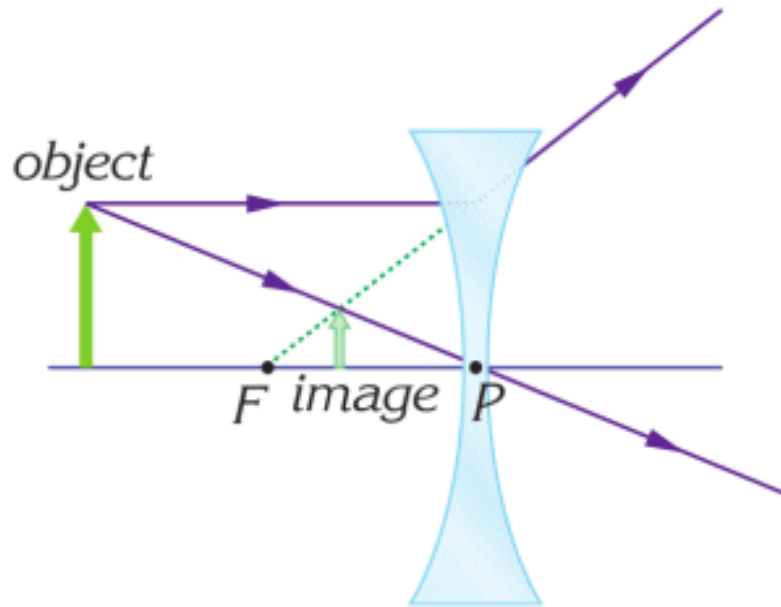

Figure 2

The image here is smaller (not bigger), upright (not inverted), virtual (not real). The image is virtual because rays do not intersect.

FORMULA OF LENS

$$-\frac{1}{F} = \frac{1}{d} - \frac{1}{f}$$

F: focal length of a lens (meters). The focal length of a diverging lens is ALWAYS negative (minus).

d : distance between the lens and the object (meters)

f : distance between the lens and the image (meters)

The formula for the diverging lens contains negative f . It is because this lens always produces a virtual image.

MAGNIFICATION OF IMAGE

For magnification, we can use the formula from the previous topic.

However, a diverging lens always produces the image smaller than the object.

FACT



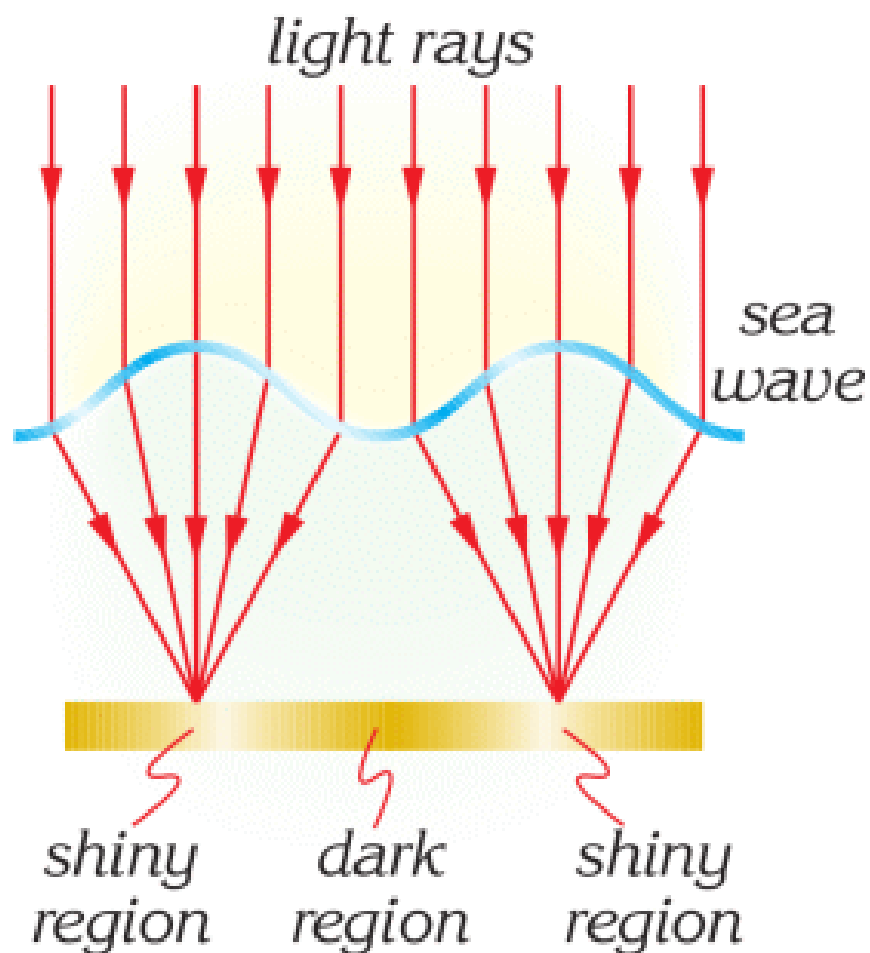

The tops of the waves are converging lenses. They collect light. That's why we see shiny and dark regions in the water.

EXAMPLE

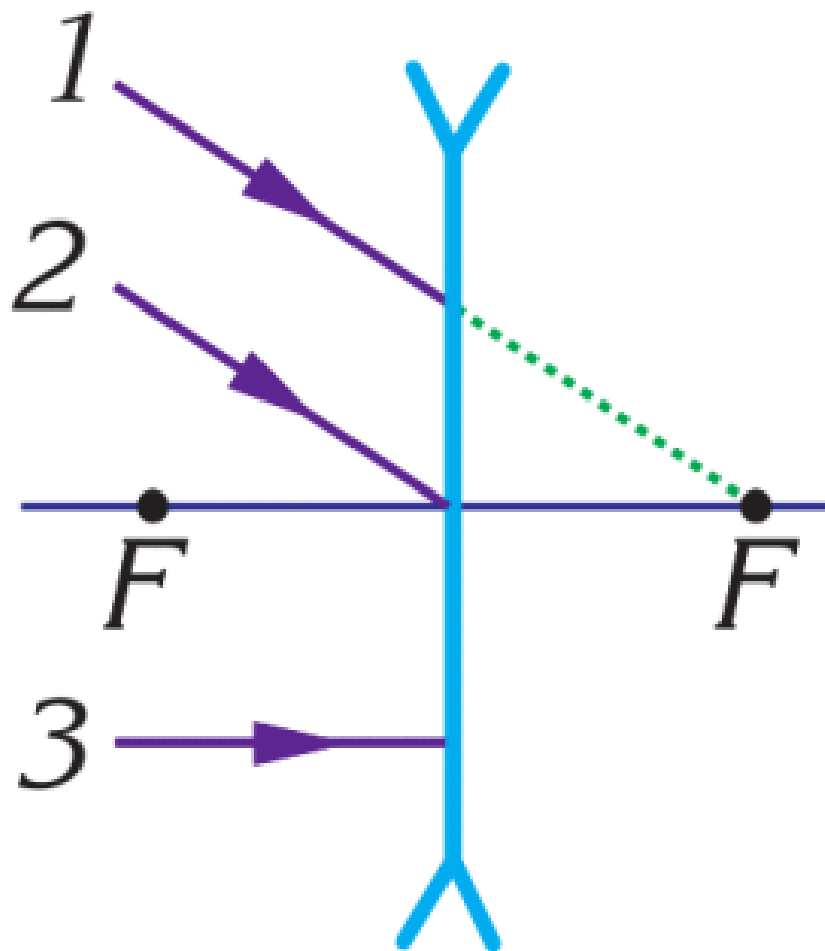

Draw the correct paths of the rays.

Solution: Use special rays 1, 2 and 3.

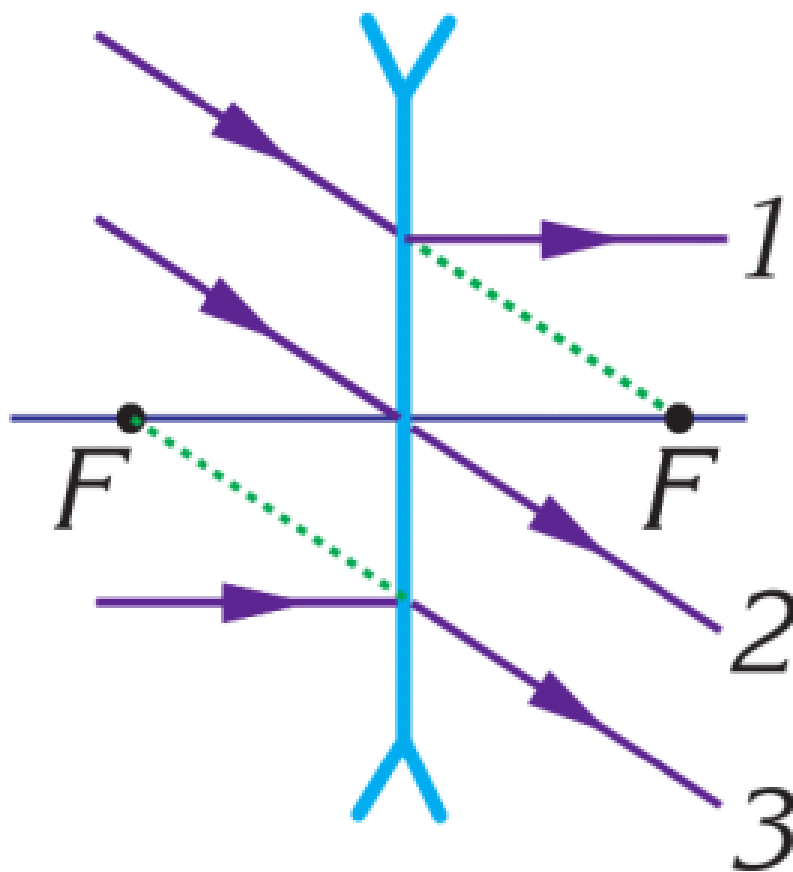

EXAMPLE

An object is 0.2 m away from a diverging lens. Focal length is -0.1 m.

- Draw lens, object, and image. Determine the distance of image.
- Determine magnification.
- List image properties.

Solution:

Using the special rays, we sketch the diagram as in the figure.

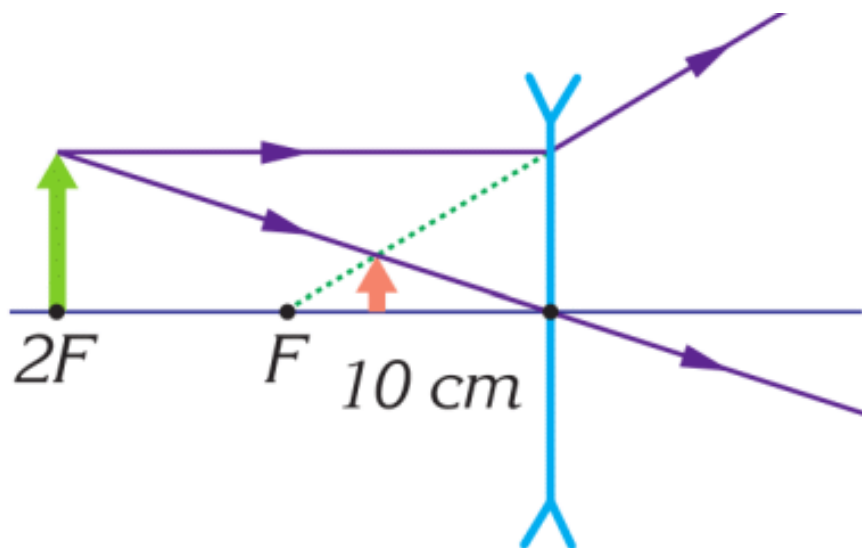

$$a. \frac{1}{F} = \frac{1}{d} + \frac{1}{f}; \quad -\frac{1}{0.1} = \frac{1}{0.2} + \frac{1}{f}; \quad f = -0.067 \text{ m} = -6.7 \text{ m};$$

$$b. M = \frac{-f}{d}; \quad M = \frac{-(-0.067)}{0.2} = 0.33 = 33 \%;$$

c. Virtual, upright, diminished.

RESEARCH TIME

Material: laser pointer, eyeglasses

Procedure: Mark a point on the paper. Direct the laser towards the point. Put the lens of the eyeglasses on the way of the laser. What happens to the laser point on the paper?

Determine if the lens is divergent or convergent.

LITERACY

1. Why is the image small in the diverging lens? How do rays travel through diverging lenses to your eyes?
2. At what distance is the diverging lens placed, if you see words twice smaller than they are? The diverging lens has a focal length of -20 cm.
3. Why do near-sighted people use diverging lenses in glasses? Why do people become near-sighted?
4. Draw an image of any object. Determine image distance and magnification. List its properties. Focal length is -25 cm. The object is at 30 cm from the diverging lens.

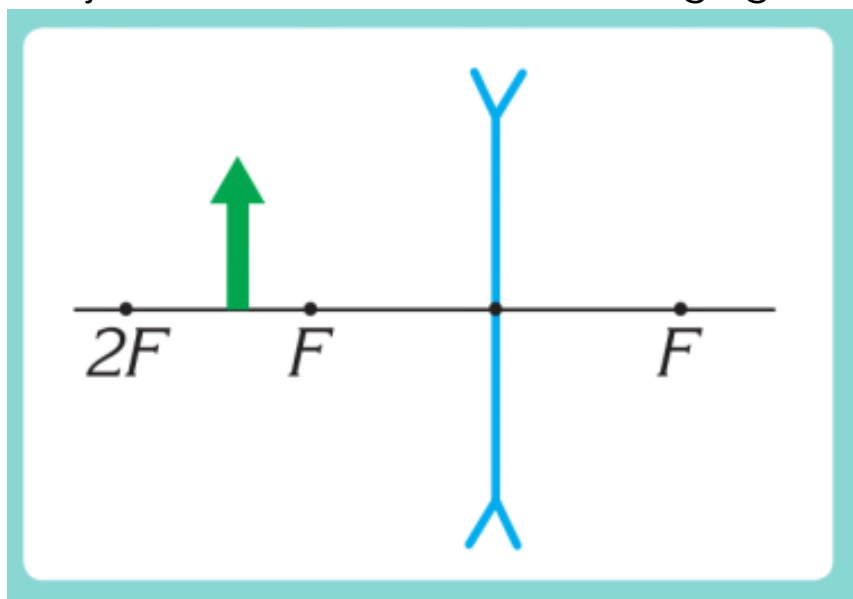

TERMINOLOGY

diverging lens – шашыратқыш линза / рассеивающая линза

intersection point – қиылысу нүктесі / точка пересечения

7.9 HUMAN EYE AND OPTICAL DEVICES

YOU WILL:

- - describe the correction of myopia and hyperopia.

QUESTION



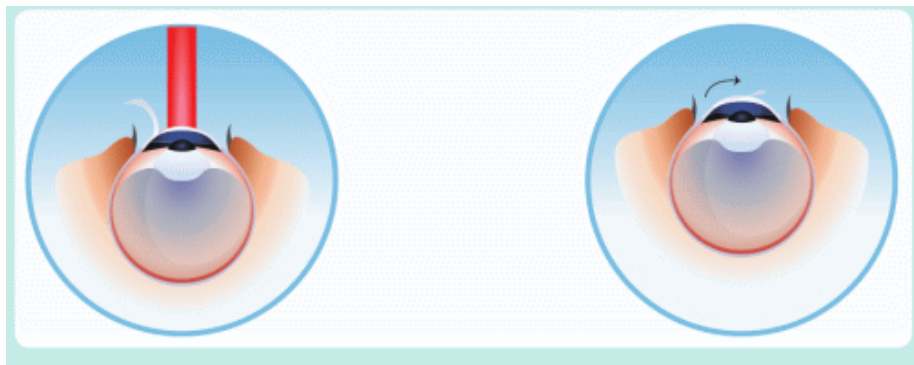
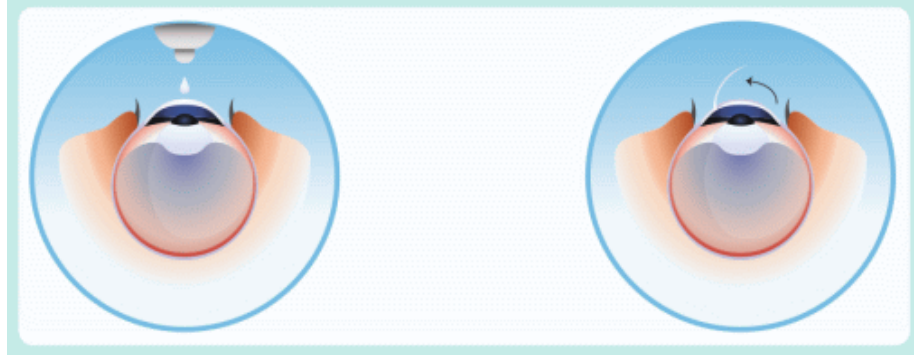

Why do people have laser eye surgeries?

HUMAN EYE

A human eye has two lenses.

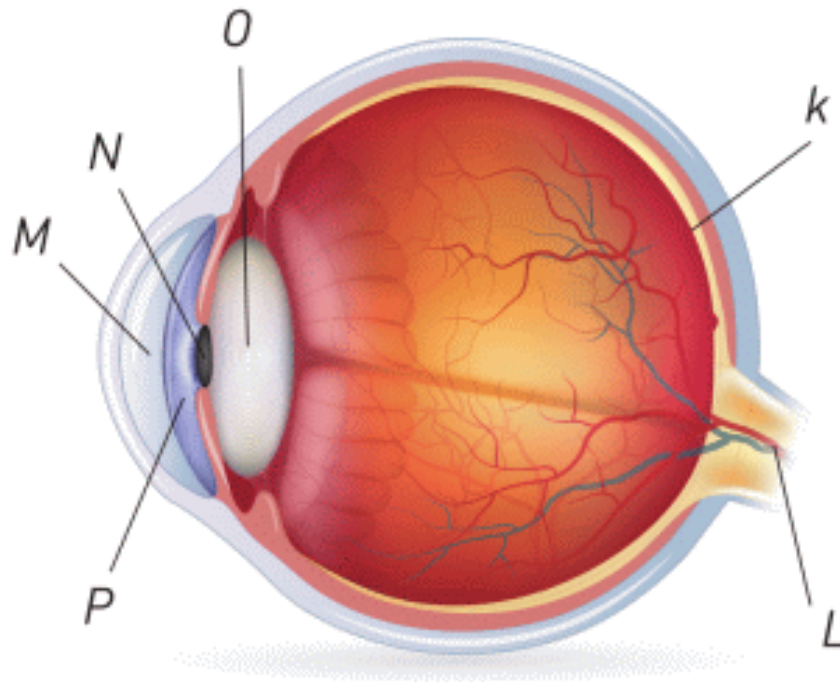

Figure 1

1. Cornea (Part M in the figure)

2. Lens (Part O in the figure)

These two lenses collect light on the retina (part K in the figure). Retina has cells that change the light (photons) into the electric current. This current travels to the brain by an optic nerve (part L in Figure 1).

NORMAL VISION AND EYE DEFECTS

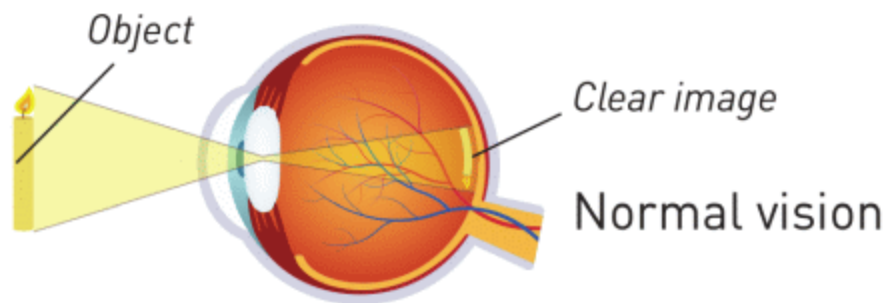
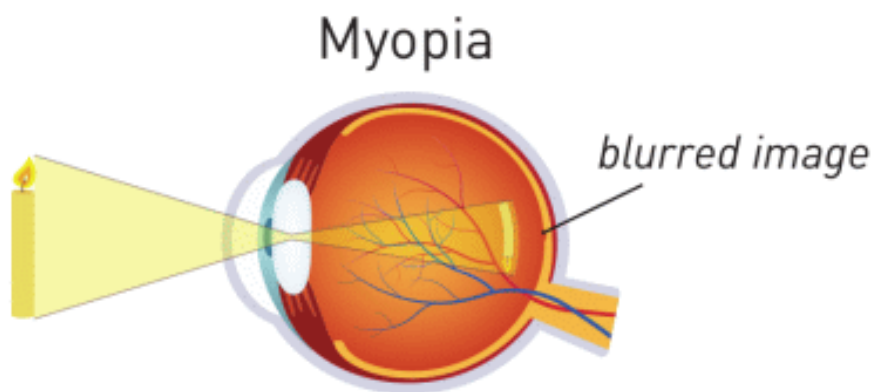

Figure 2

Сау көзде кескін торламада орналасады, Figure 2.

MYOPIA (NEARSIGHTED EYE)

Миопия (алыстан көрмеушілік, жақыннан көргіш көз) Анық кескін торламаға жетпей қалыптасады, Figure 3 а. Сондықтан торламаның өзінде кескін анық болмайды. Осындай кемшілігі бар адамдар жақынды жақсы көріп, алысты анық көре алмайды.



а

Figure 3

HYPEROPIA (FARSIGHTED EYE)

Гиперопия (жақыннан көрмеушілік, алыстан көргіш көз) Анық кескін торламаның артында қалыптасады, Figure 3 b. Сондықтан торламаның өзінде кескін анық болмайды. Осындай кемшілігі бар адамдар алысты жақсы көріп, жақынды анық көре алмайды.

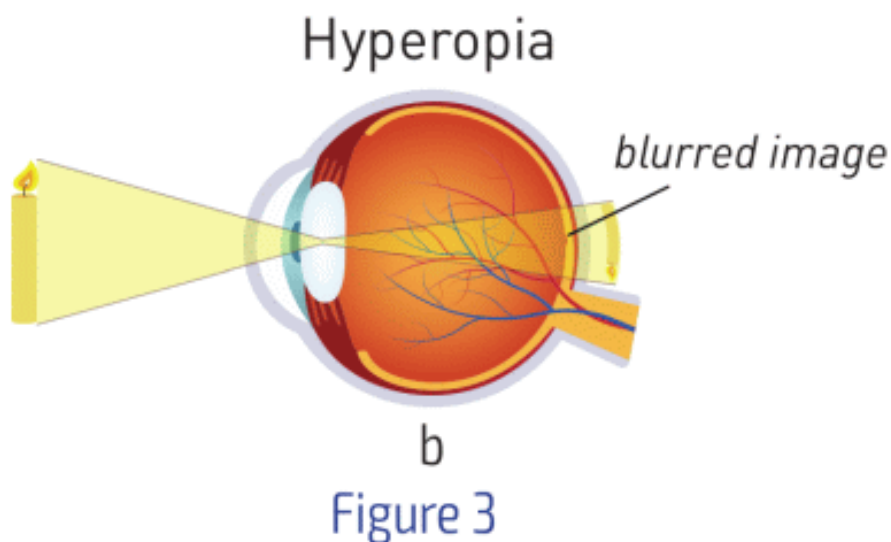

FACT

How to care for your eyes

- - Do not look at the Sun
- - Do not use screens (smartphones, tablets, laptops, computers, TV) for a long time
- - Check your eyes regularly
- - Do not use alcohol, drugs, and cigarettes
- - Sleep well

ACTIVITY

Optical devices









Fill the table.

Optical Device	Why, where, who does use this device?	Components that this device may use (mirrors, lenses, prisms, optical fibers)?
Doctor's head mirror		
Flashlight		
Side view mirror		
Endoscope		
Periscope		
Binoculars		
Microscope		
Magnifying glass		
Eyeglasses		
Photo camera		
Telescope		
Projector		
Car headlight		

DISCUSSION

Defect	Lens (diverging or converging)	Why? Explain your answers.
Myopia		
Hyperopia		

We use glasses for near-sighted and farsighted people. What lenses do we use for near-sighted people and farsighted people? Write your answers in the table. Use figure 3 for help.

RESEARCH TIME

Telescope

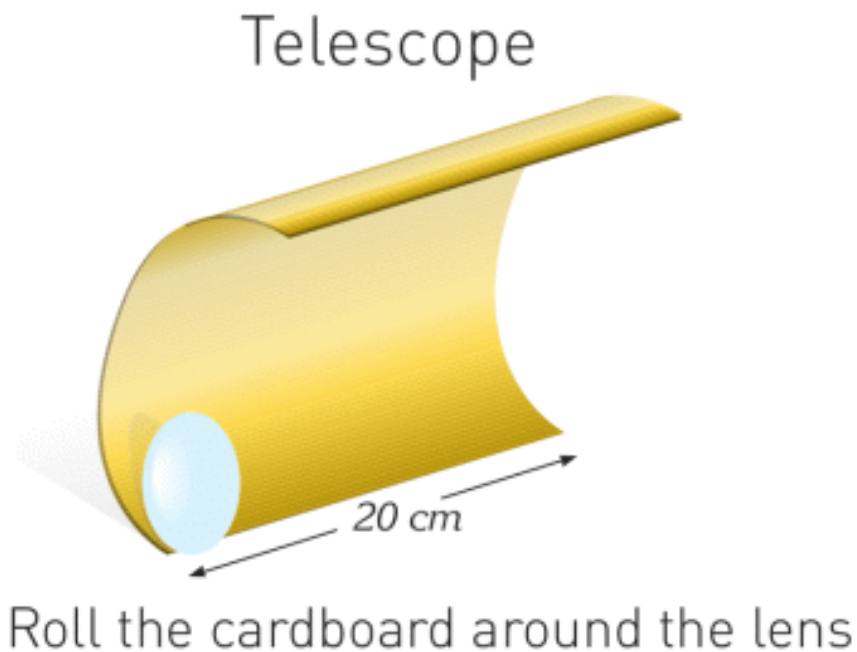

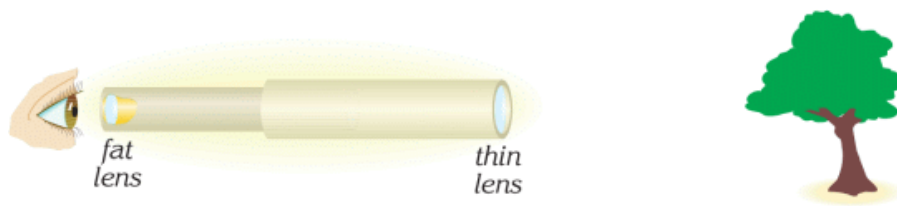

Slide the tubes backwards and forwards to obtain a magnified image

Use glue to fix the lens to the tube. Make another tube with the other lens. Insert the tube with the fat lens into the tube with the thin lens.

LITERACY

1. Why do people do LASIK (laser eye surgery)? How does LASIK (laser eye surgery) work?
2. Why do people become near-sighted, farsighted or astigmatic? What can you do to save eyesight?
3. Why do you have a lens in your eye? How does this lens work? What is the material of eye lens?
4. Why do people wear glasses? Are contact lenses better than glasses? Why?
5. Why do we use pinhole camera? How does pinhole camera work? Is pinhole camera similar to the human eye?
6. Why do we use periscopes, binoculars, microscopes, telescopes? How do they work?

ART TIME

Make models of a near-sighted, farsighted and normal eye. What is the difference between them? Make models and show them to parents, teachers and friends.

TERMINOLOGY

retina – торлы қабық / сетчатка

myopia – алыстан көрмеушілік / близорукость

hyperopia – жақыннан көрмеушілік / дальнозоркость

LABWORK 10

TITLE:

Index of refraction

OBJECTIVES:

To determine the index of the refraction of the glass.

MATERIALS LIST:

1. glass prism
2. laser (or light source)
3. graphing paper
4. ruler
5. protractor
6. scientific calculator

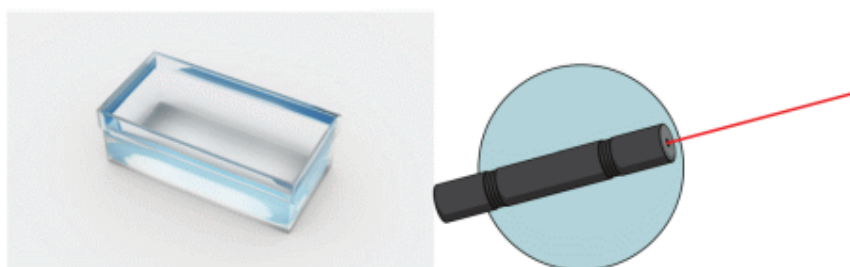

SAFETY:

1. Use a hot mitt to handle resistors, light sources, and other equipment that may be hot.
2. Allow all equipment to cool before storing it.
3. Never put broken glass or ceramics in a regular waste container. Use a dustpan, brush, and heavy gloves to carefully pick up broken pieces, and dispose of them in a container specifically provided for this purpose.
4. Avoid looking directly at a light source.
5. Looking directly at a light source may cause permanent eye damage. Always wear eye protection during this exercise.

THEORY:

1. Why does ray change direction in prism?
2. Why does light travel slower in glass than in air?
3. Why do we use glass in optical devices? Why don't we use other materials?
4. How do we determine the index of refraction?
5. What is the index of refraction of air?
6. What is the index of refraction of glass?
7. Why do we use the Snell's law of refraction?

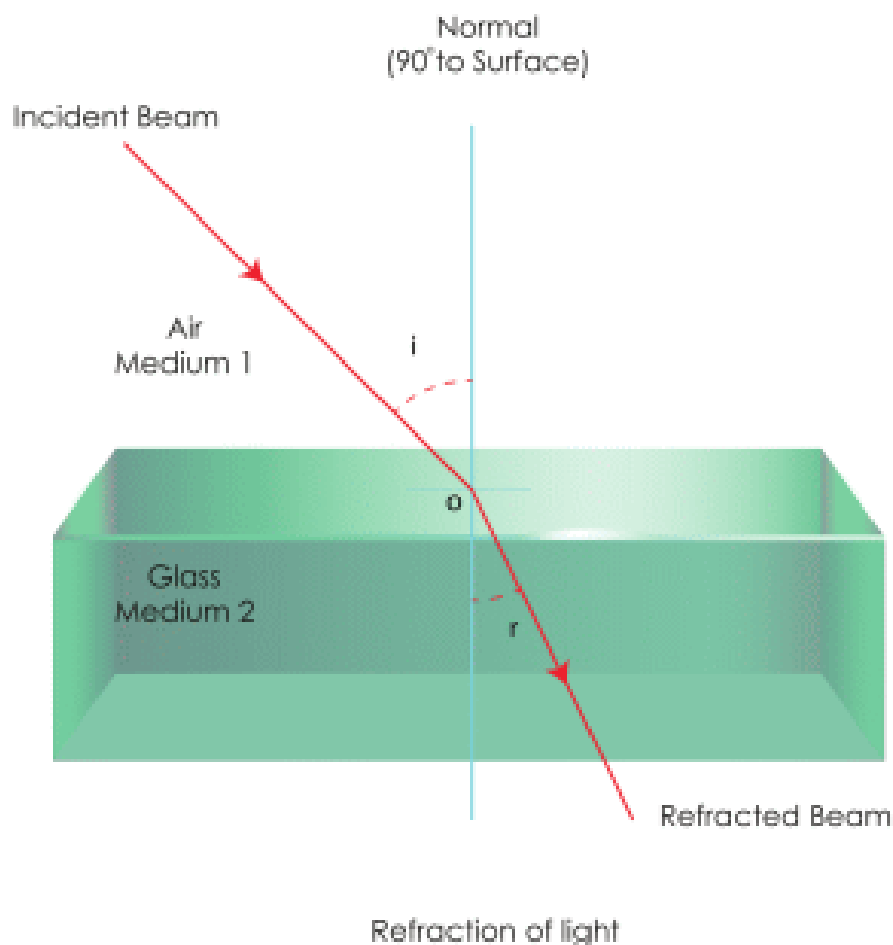

PROCEDURE:

1. Put a prism on the graphing paper. Draw an outline of the prism.
2. Direct the ray to prism. Mark two points on the ray.
3. Mark a point at which the ray enters the prism.
4. Mark a point at which the ray exits the prism.
5. Remove the prism from the graphing paper.
6. Use the points to draw the incident ray and the refracted ray.
7. Use a protractor to measure the angle of the incidence and the angle of the refraction.

8. Use the law of refraction to determine the index of refraction of the glass.

Angle of incidence (degrees)	
Angle of refraction (degrees)	
$\sin i$	
$\sin r$	
Index of refraction of air	
Index of refraction of glass	

ANALYSIS:

Index of refraction of glass = _____

CONCLUSIONS:

1. Why is your index of refraction of the glass more than (or less than, or same as) value in the book?
2. How can you use prisms in new ways?

LABWORK 11

TITLE:

Optical power of lens

OBJECTIVES:

To determine focal length of lens.

MATERIALS LIST:

1. lens
2. laser (or light source)
3. ruler
4. graphing paper

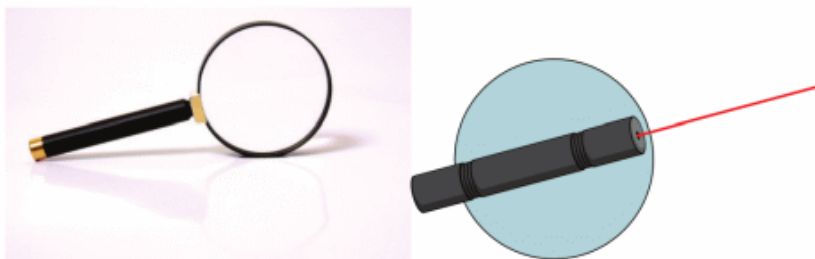

SAFETY:

1. Use a hot mitt to handle resistors, light sources, and other equipment that may be hot. Allow all equipment to cool before storing it.

2. Never put broken glass or ceramics in a regular waste container. Use a dustpan, brush, and heavy gloves to carefully pick up broken pieces, and dispose of them in a container specifically provided for this purpose.
3. Avoid looking directly at a light source. Looking directly at a light source may cause permanent eye damage. Always wear eye protection during this exercise.

THEORY:

1. Why do we use lenses? How can you make lenses? What materials can you use to make lenses?
2. What is the difference between converging and diverging lenses?
3. How can you determine focal length of the lens? What is the focal length of the lens?
4. How can you determine optical power of the lens? What is the optical power of the lens?

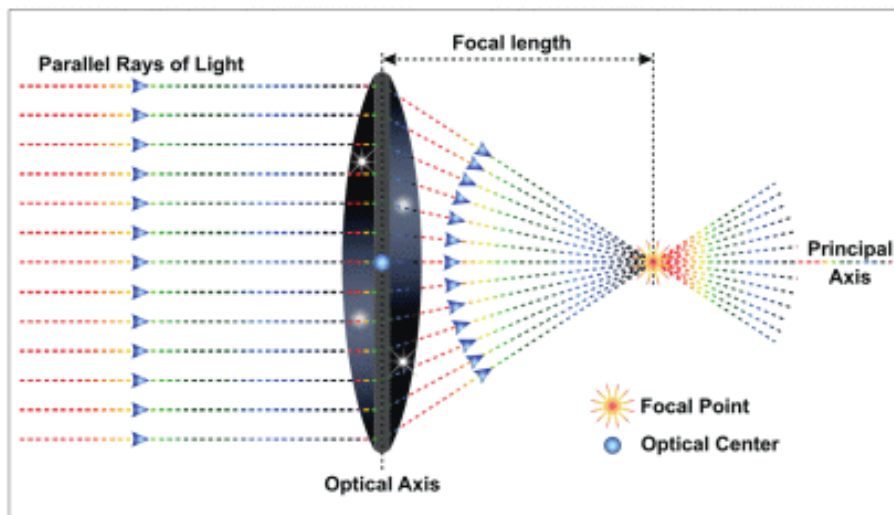

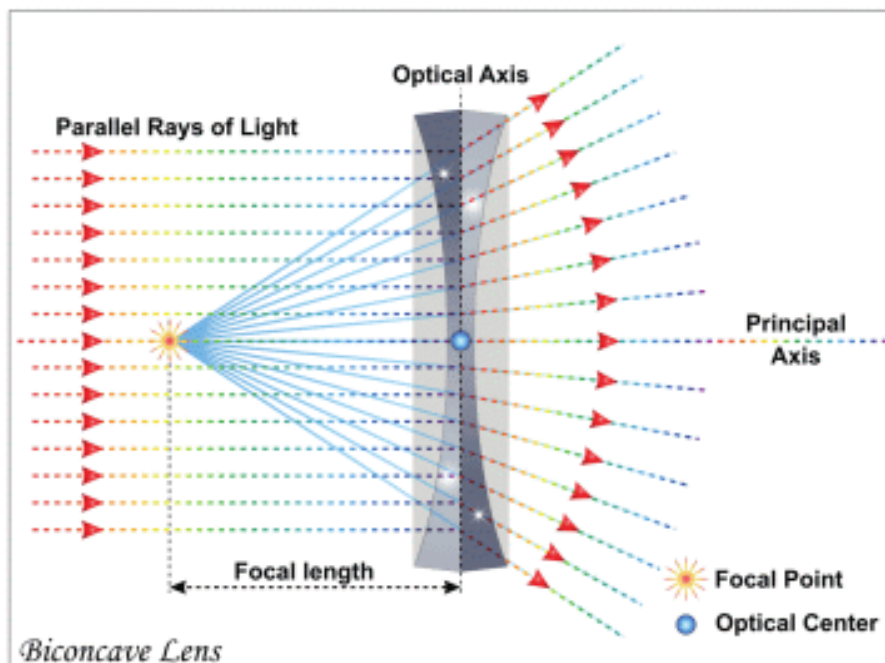

PROCEDURE:

1. Put the lens on the graphing paper.
2. Draw the outline of the lens.
3. Draw the principal axis of the lens on the graphing paper.
4. Direct the ray to the lens parallel to the principal axis.
5. Mark two dots on the incident ray and two dots on the refracted ray.
6. Remove the laser (light source) and the lens.
7. Use dots to draw the incident ray and the refracted ray.
8. Change the position of the laser (light source).
9. Repeat steps 4-5-6-7.
10. Mark the point at which two incident rays and principal axis intersect.
11. Measure the focal length of the lens.
12. Calculate the optical power of the lens.

ANALYSIS:

Focal length (meters)	
Optical power (diopter)	

CONCLUSIONS:

1. How does the focal length of the lens depend on the shape of the lens?
2. How can you use lenses in new ways?

SUMMARY

- Light is a type of energy. Light travels in a straight line.
- When you put an opaque object in the path of light, a dark region (shadow) called umbra forms on the screen.
- Penumbra is a region with half shadow.
- We see objects because they produce or reflect light.
- Atoms of mirror absorb the incident light and emit the reflected light. “N” is normal (perpendicular) line to mirror.
- The angle between “N” and the incident ray is called the angle of incidence. The angle between “N” and the reflected ray is called the angle of reflection.

There are two rules for the reflection of light:

1. The angle of incidence is equal to the angle of the reflection.
 2. The incident ray, the reflected ray and the normal are all in the same plane.
- To construct an image you need to send at least two rays. When we draw rays, we apply the law of reflection.
 - Concave mirror reflects all parallel rays to one point. This point is called a focal point.
 - Parallel light rays travel in different directions after reflection from the convex mirror. Extensions of these reflected rays appear to come from one point. This point is the focal point of the convex mirror.
 - When the light passes from one medium into another, it changes direction. This is called refraction of light.
 - We need an index of refraction to find the path of light rays in mediums. To do it, we use the law of refraction.
 -

$$n_1 \times \sin i = n_2 \times \sin r$$

- If the light is incident at an angle greater than the critical angle, the light cannot pass into the other medium and is reflected back. This is called a total internal reflection.
- A converging lens is thick at the centre. Converging lenses collect parallel rays in one point. This point is called a focal point.
- Formula of the lens
-

$$\frac{1}{F} = \frac{1}{d} + \frac{1}{f}$$

- Lens can make the image of an object bigger or smaller. Magnification shows how much an image is bigger or smaller than the object.
-

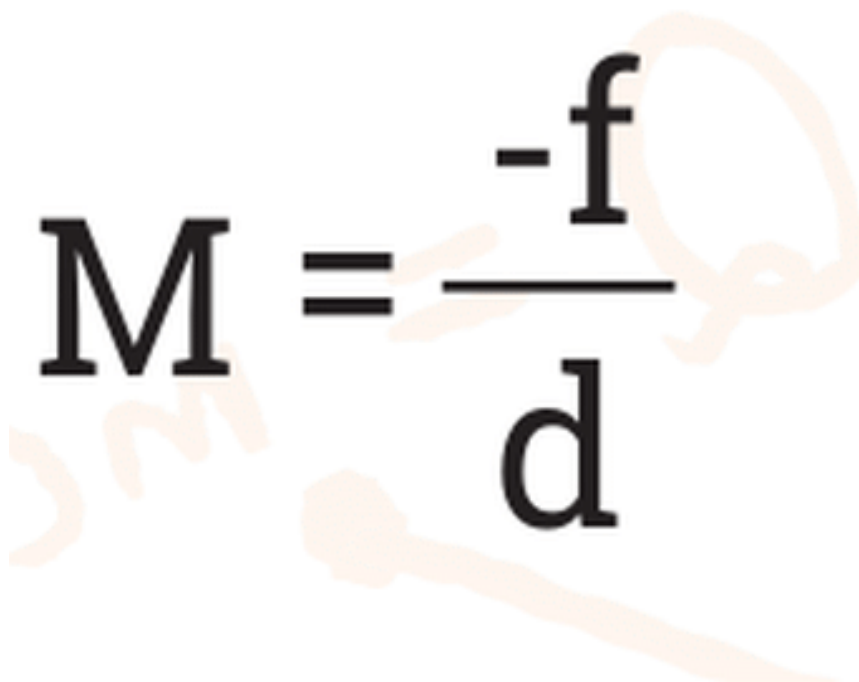
$$M = \frac{-f}{d}$$

- A diverging lens is thin at the centre. Parallel rays appear to come from a point behind the diverging lens. This point is called a focal point.

A human eye has two lenses.

1. Cornea
2. Lens

- Myopia (Near-sighted eye): Clear image forms in front of retina.
- Hyperopia (Farsighted eye): Image forms at the back of retina.

PROBLEMS

LIGHT AND SHADOW

1. Draw the shadow of each ball.

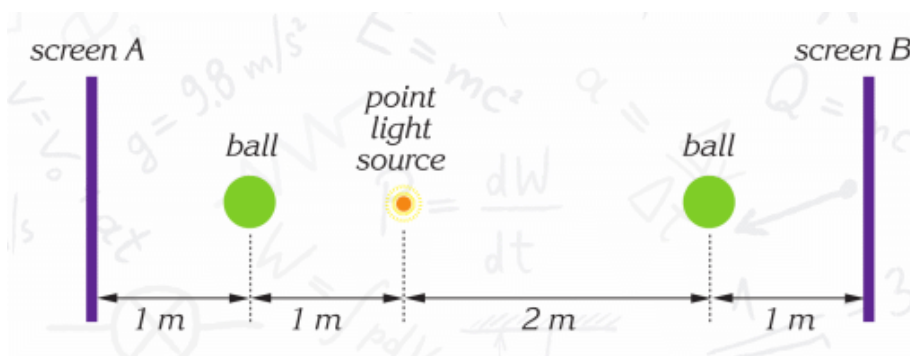

- Which shadow is greater?
- What can you do to make shadows same?
- Screen B moves to the right. How does the shadow change?

2. Where is umbra and penumbra on the screen?

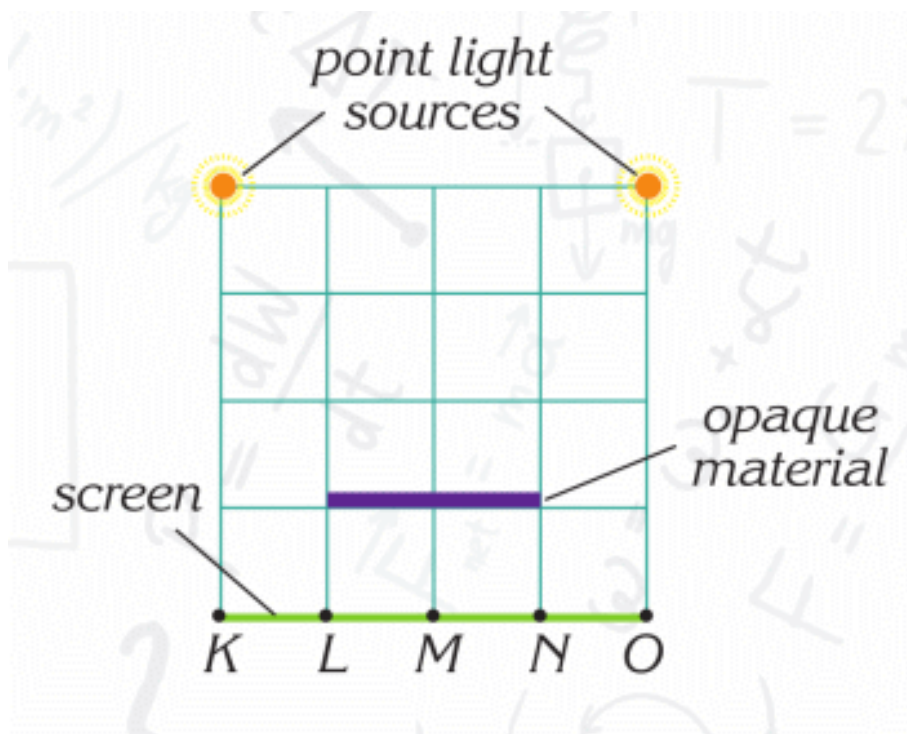

REFLECTION OF LIGHT

3. How many mirrors do you need to place in tubes to see the ball?

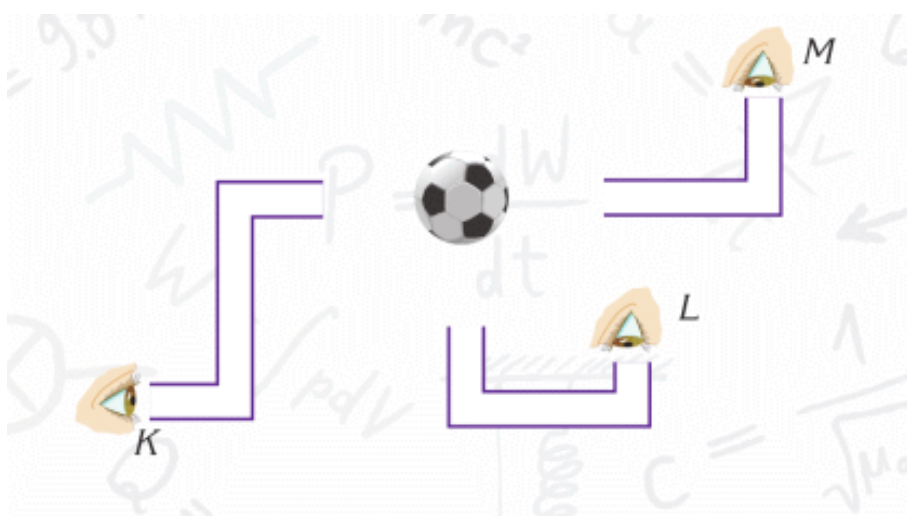

4. Height of a man is 170 cm. His eyes are 160 cm above the floor. He looks at the mirror.

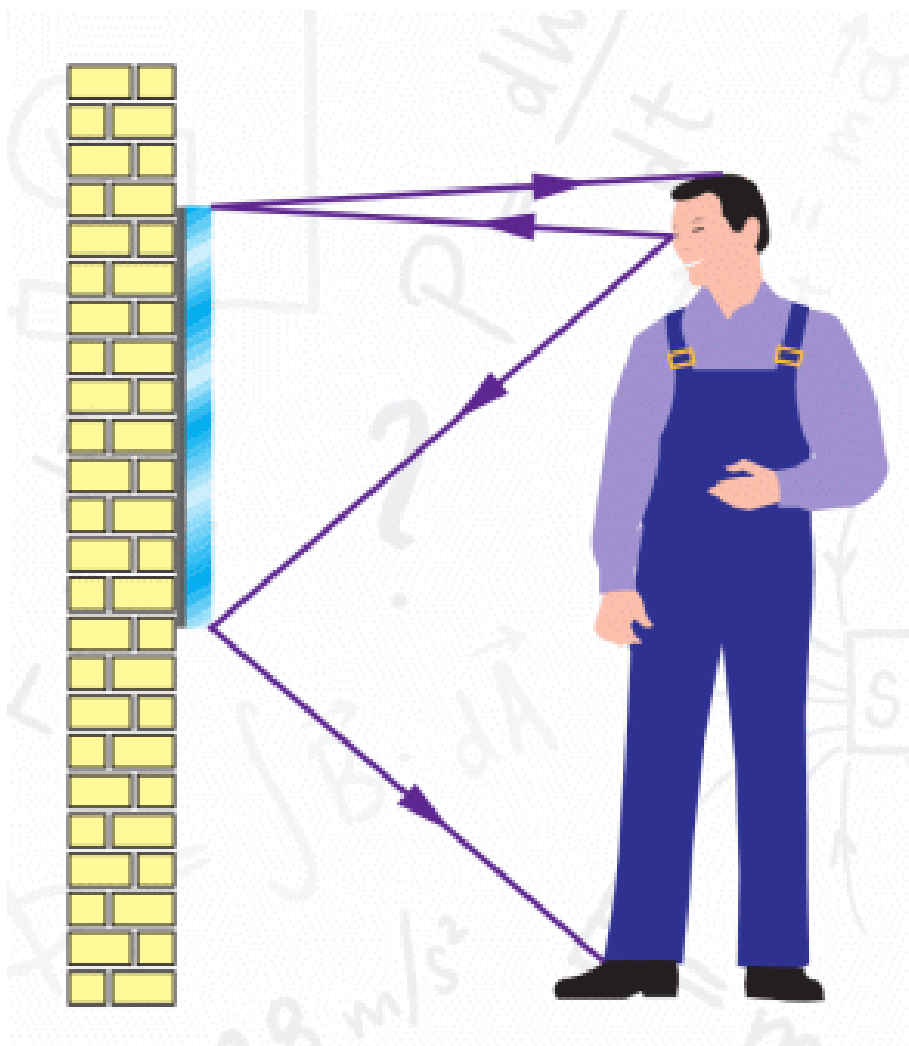

a) What should the height of the mirror be so the man can see his feet?

b) What should the height of the mirror be so he can see himself completely?

5. Which points can an eye see in the mirror?

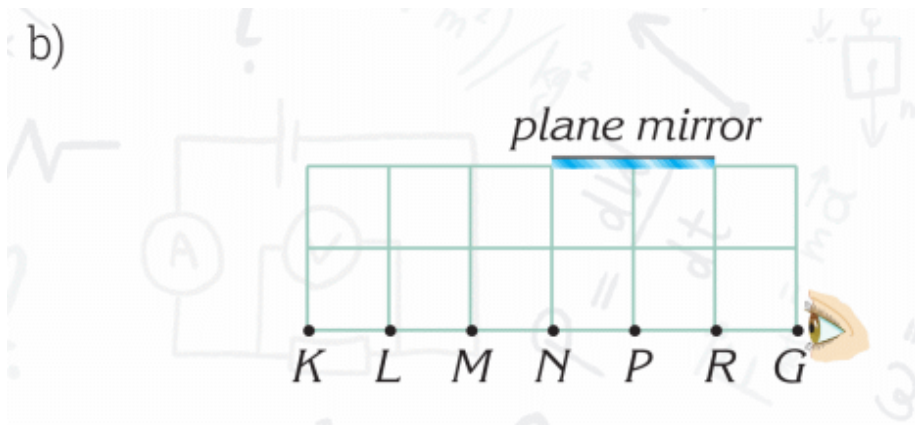
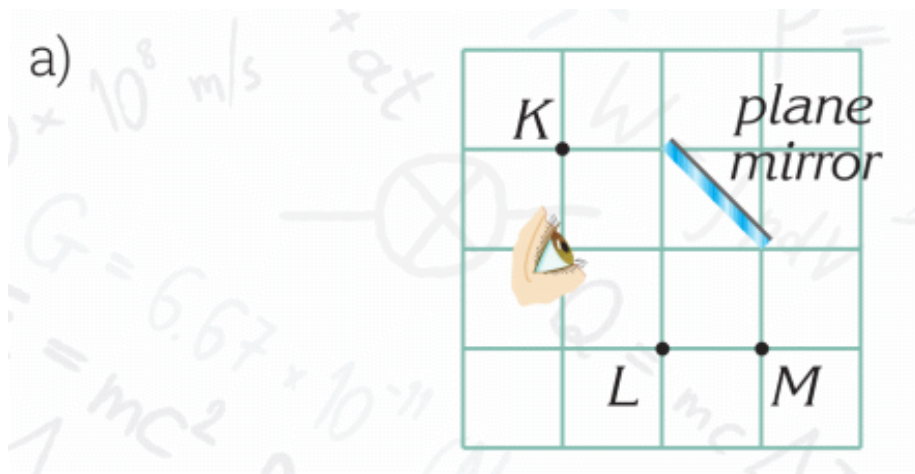

6. What is the time in the mirror?

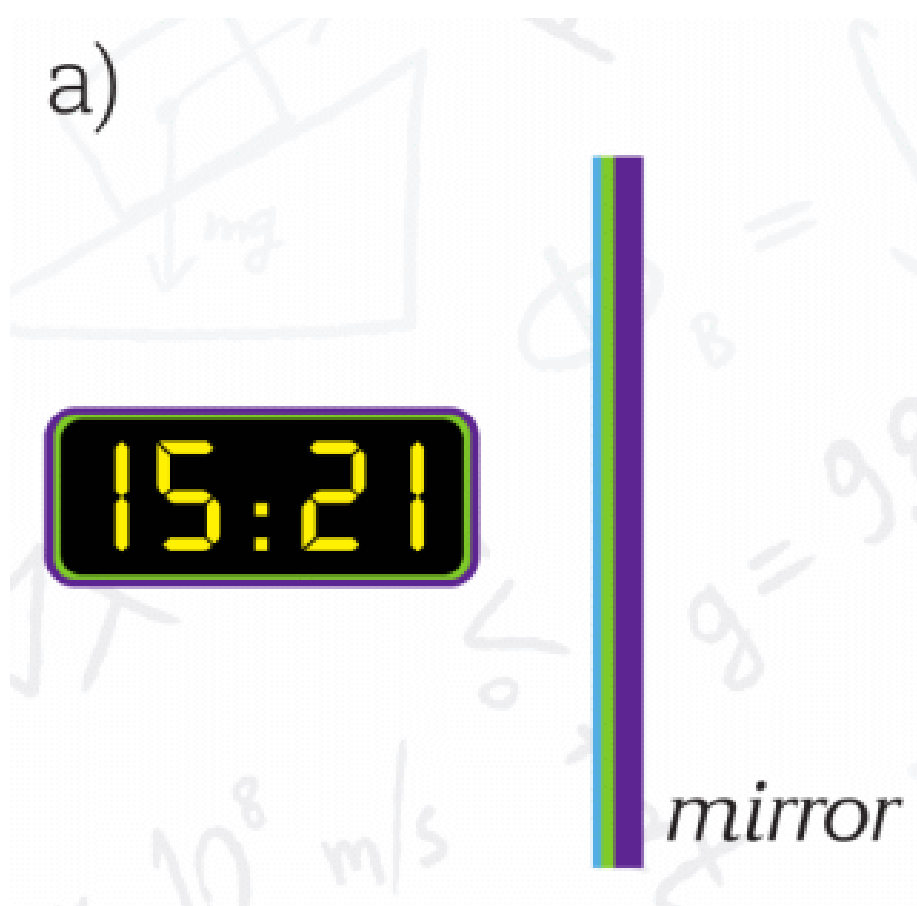

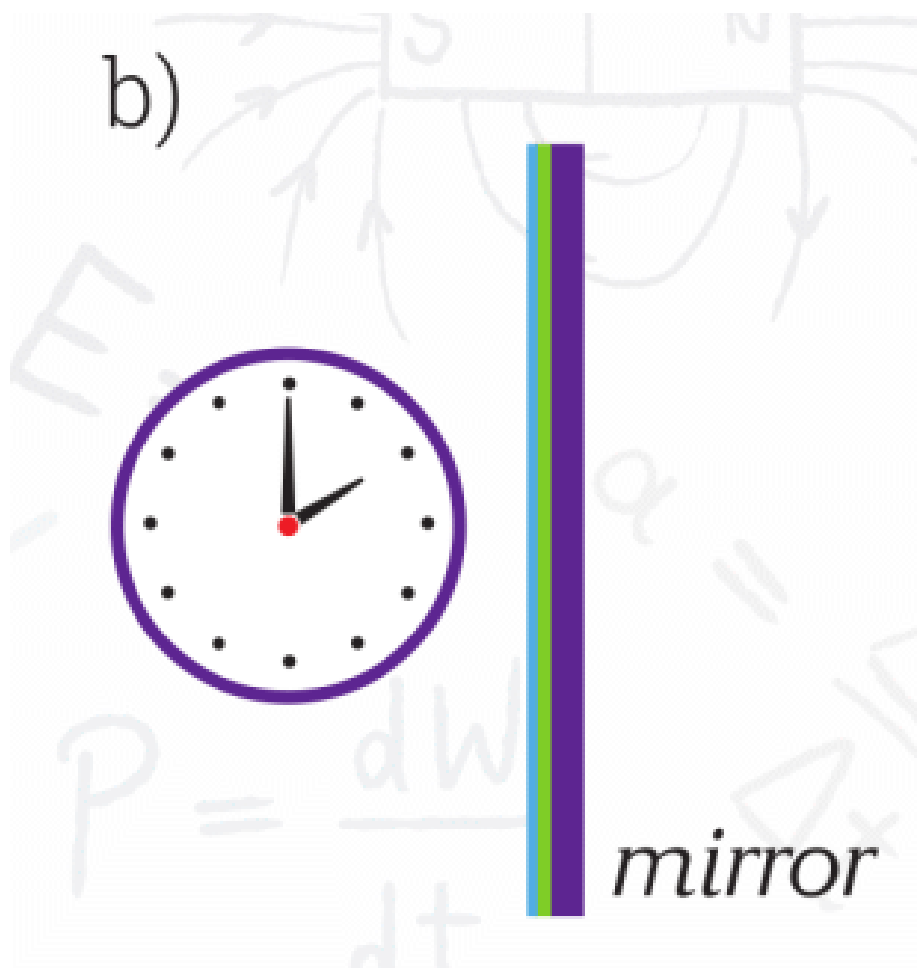

7. What are the angle of incidence and the angle of reflection?

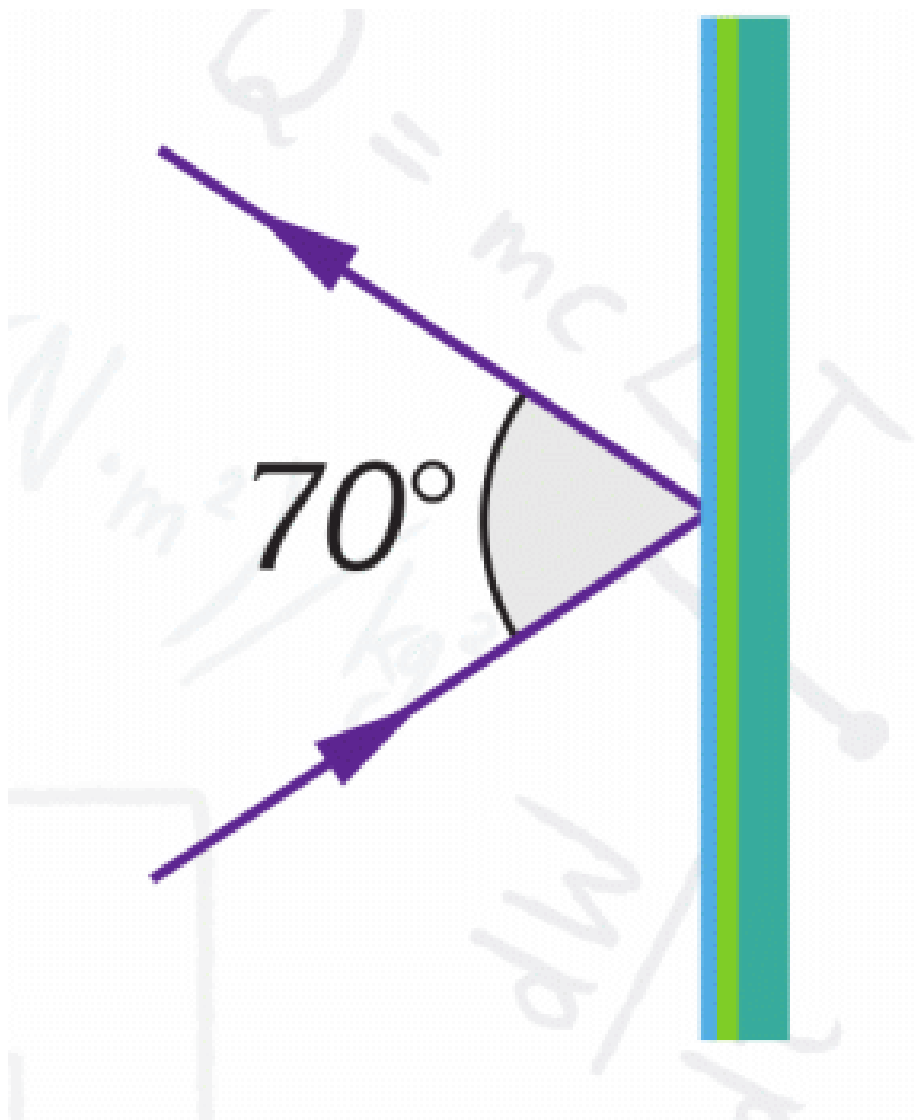

SPHERICAL MIRRORS

8. Find an image of point K by drawing. Find an image of point L by drawing. Then connect them. Do it for 2 mirrors.

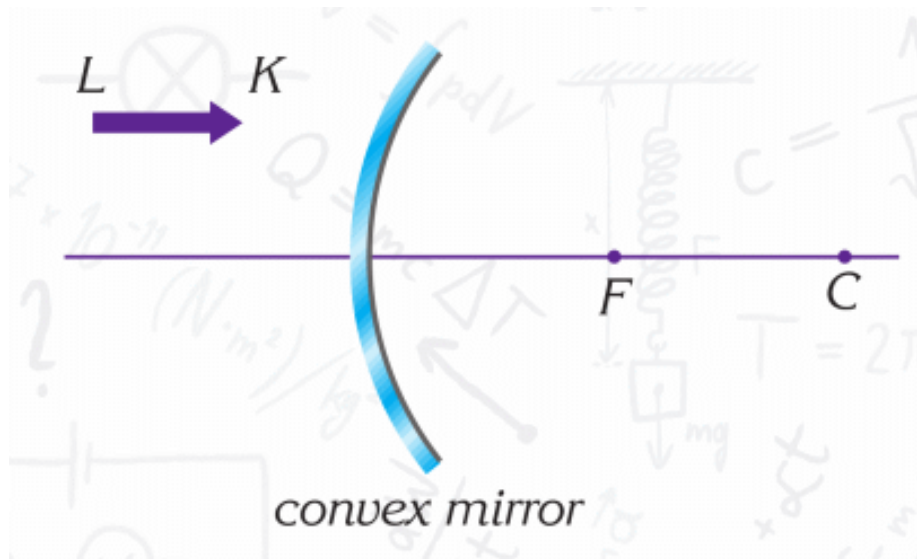
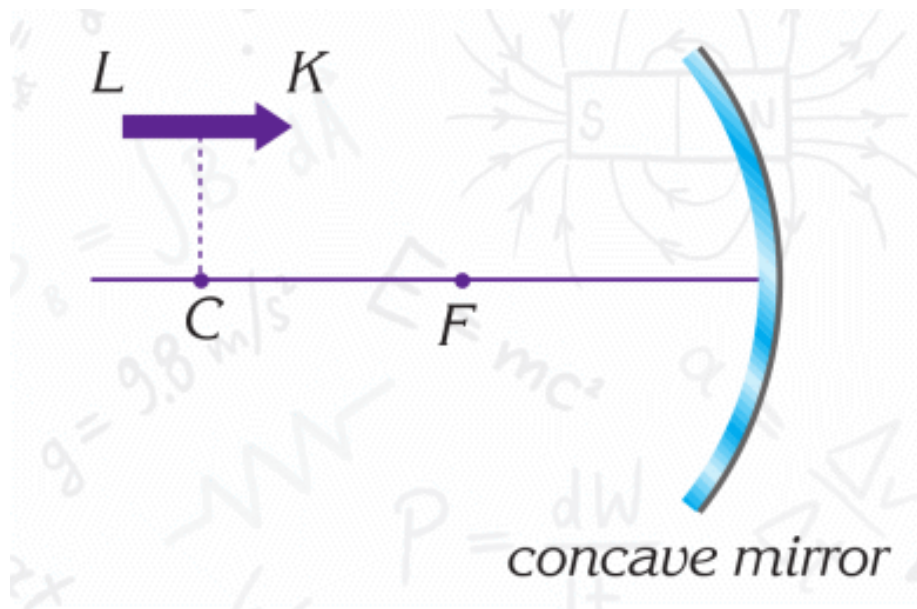

9. Draw images of objects K, L, M in concave mirror.

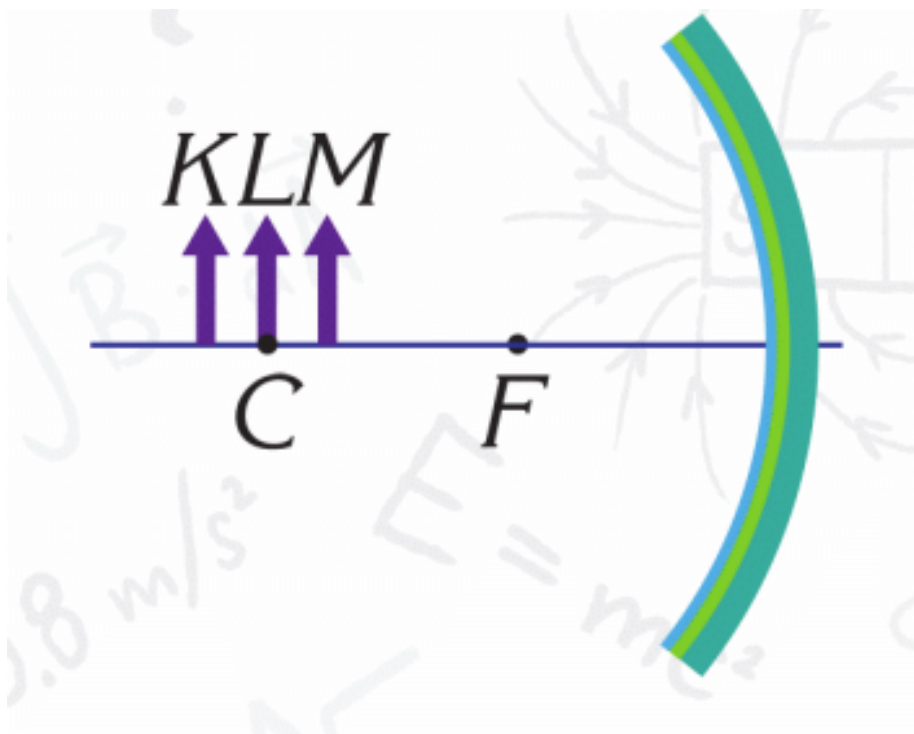

10. Calculate how many kilometres the light travels in space:

a. in a day

b. in a week

c. in a month

11. In the figure below, which points on the screen are

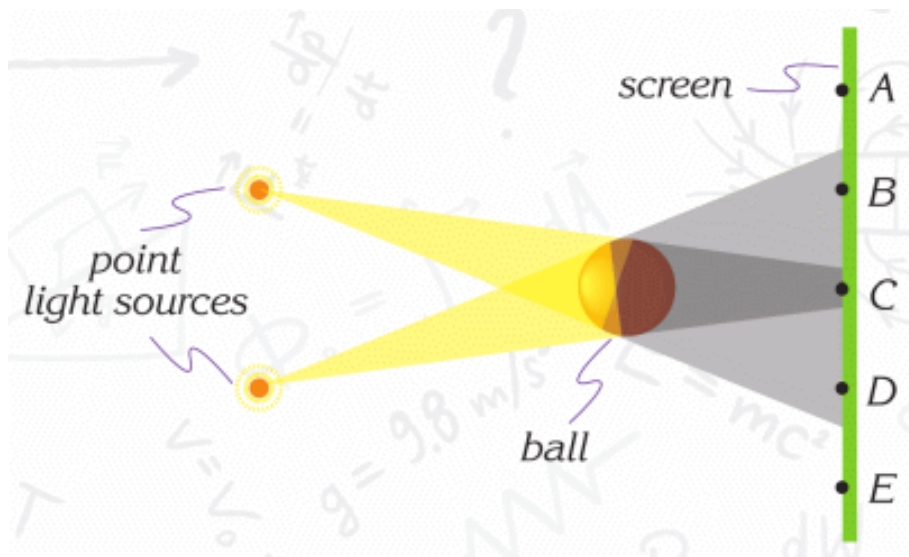

a. illuminated?

b. in the umbra?

c. in the penumbra?

12. The nearest star called Alpha Centauri is 4.2 light years away from us. Calculate how far it is from the Earth in metres.

13. The figures below show rays of light entering and leaving the optical boxes. Each box contains two plane mirrors. Show how they are placed.

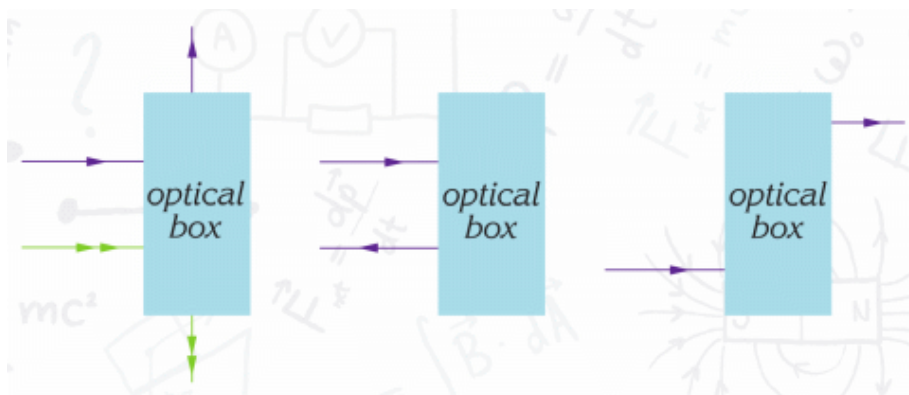

14. A boy stands 10 m in front of a plane mirror, then he moves 3 m towards the mirror. How many metres does his image move towards him?

15. Draw is the image of the arrow in a plane mirror.



16. What is the image of the number in the mirror?



17. A bottle stands 1.5 m in front of a concave mirror which has a 50 cm focal length.

a. Write down the properties of the image.

b. Where should it be placed in order to obtain a magnified image?

18. Draw images of the objects in the figures below.

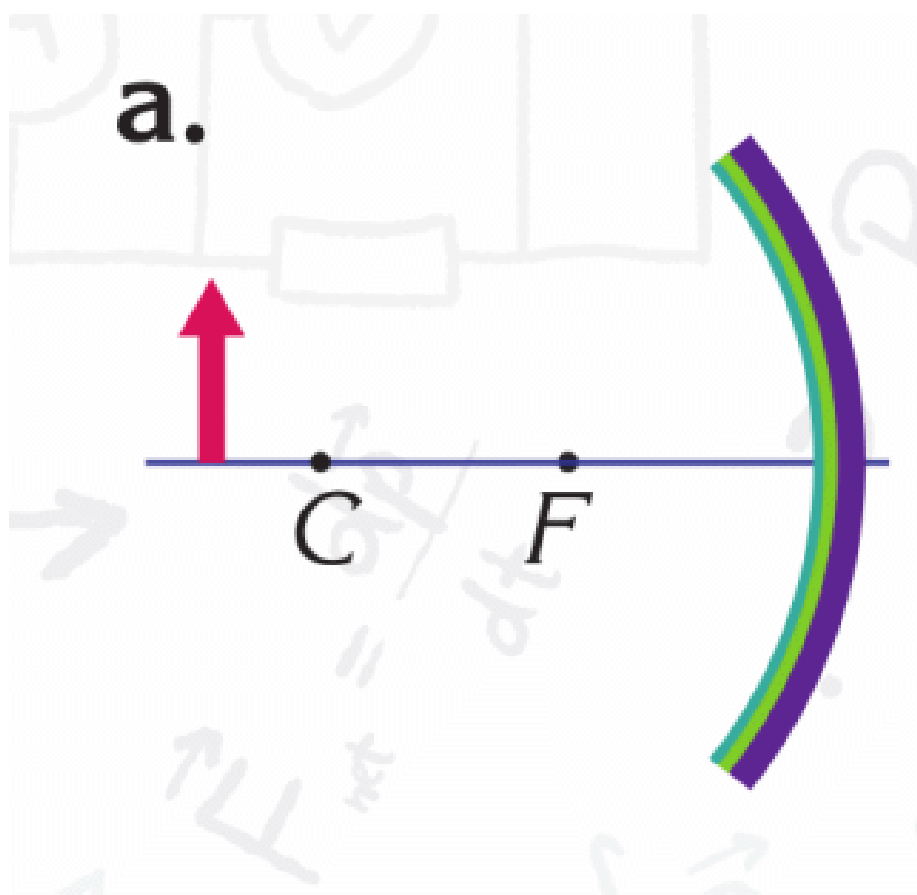

b.

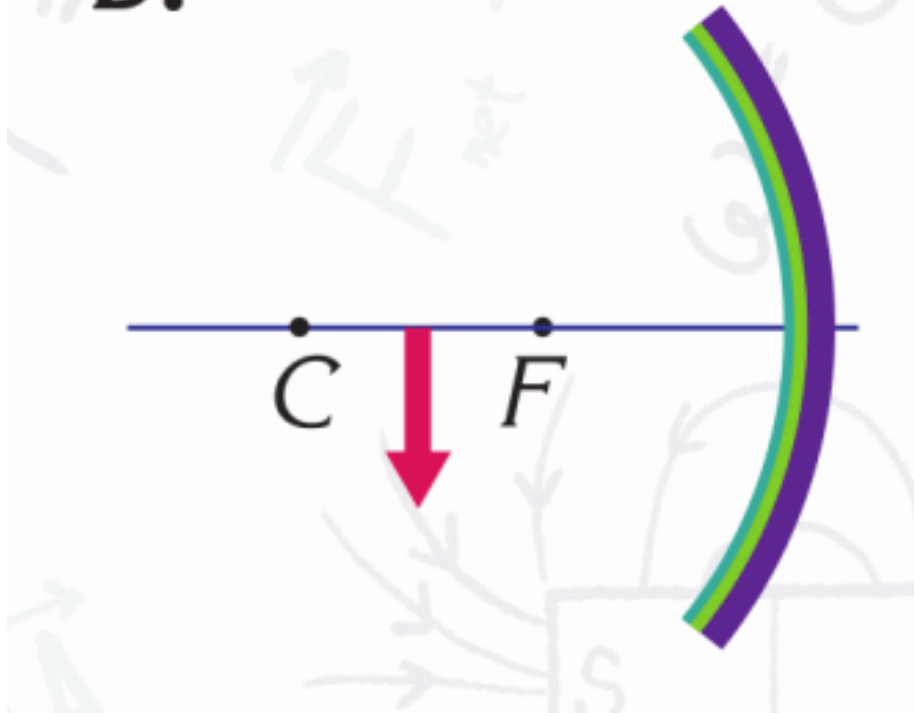

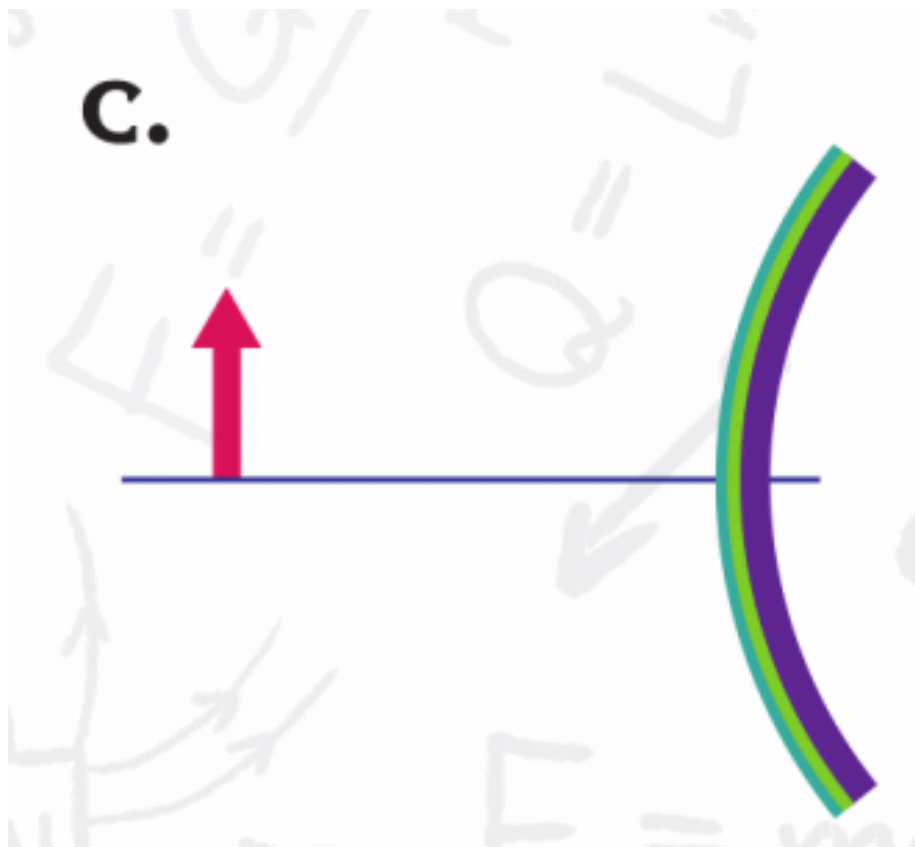

19. What is the path of the ray reflected from the mirror?

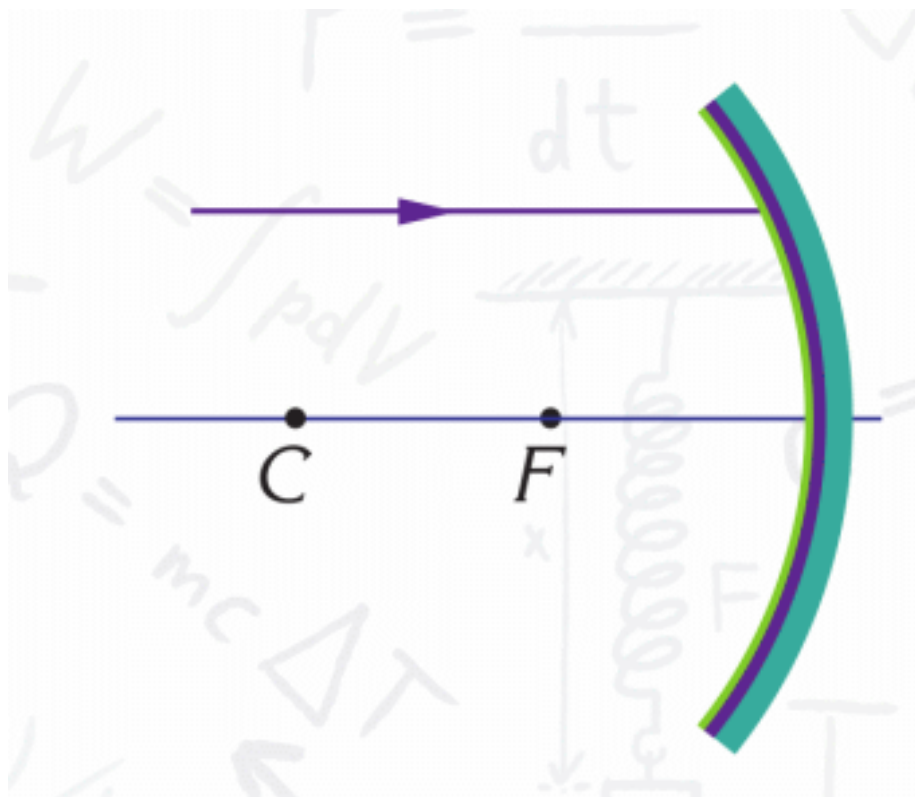

20. What is the path of the ray reflected from the mirror?

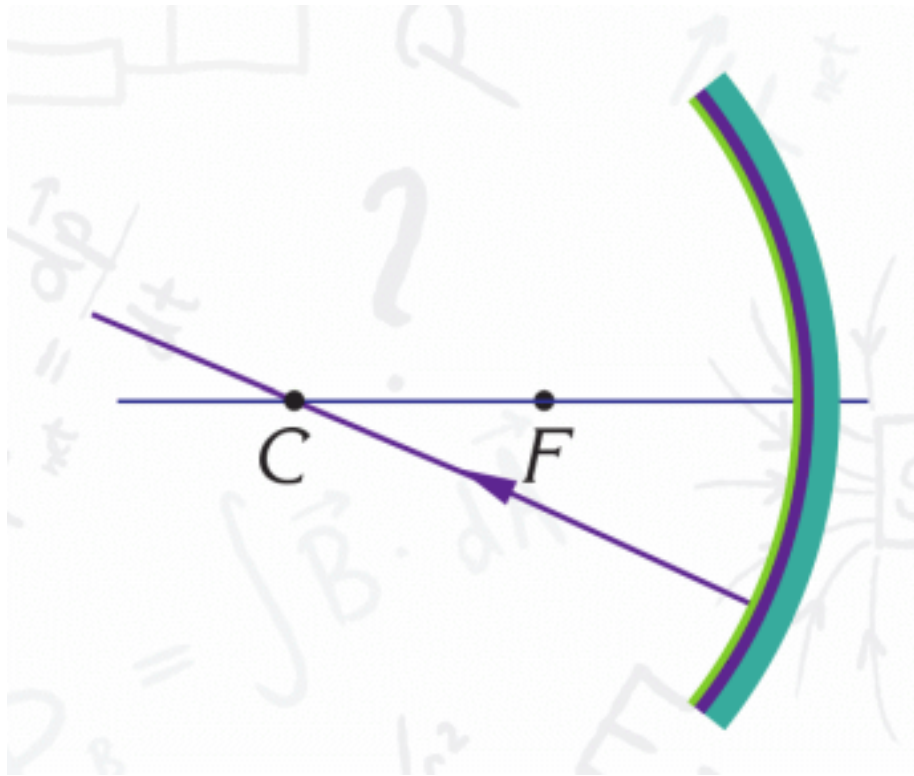

21. Which one of the rays given in the figure follows a path parallel to the principal axis after reflection?

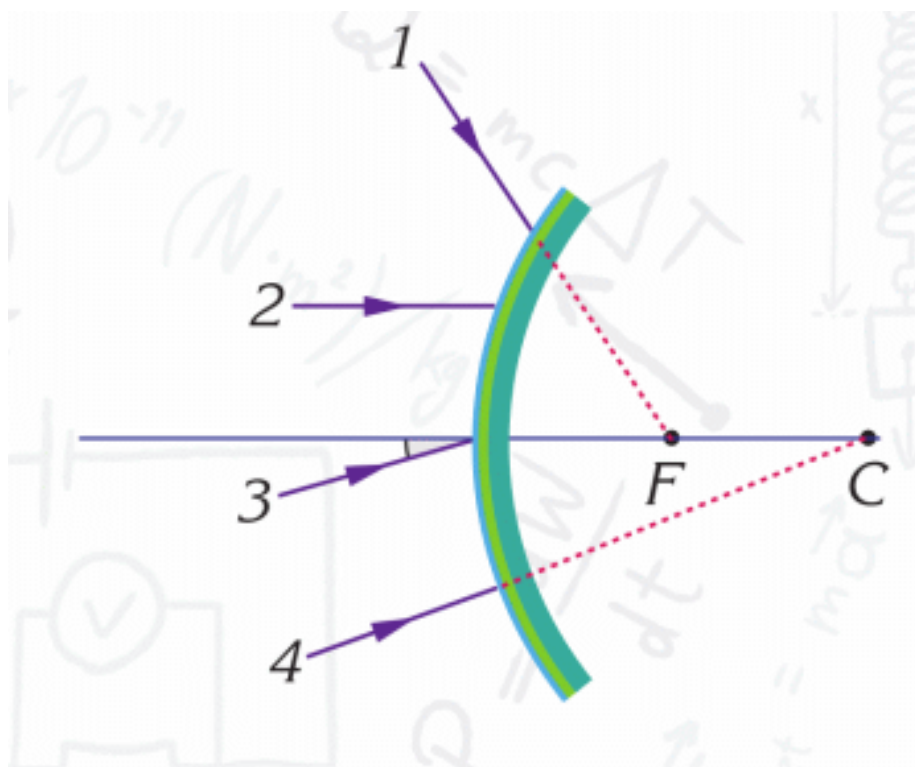

22. Complete the path of each light ray given below.

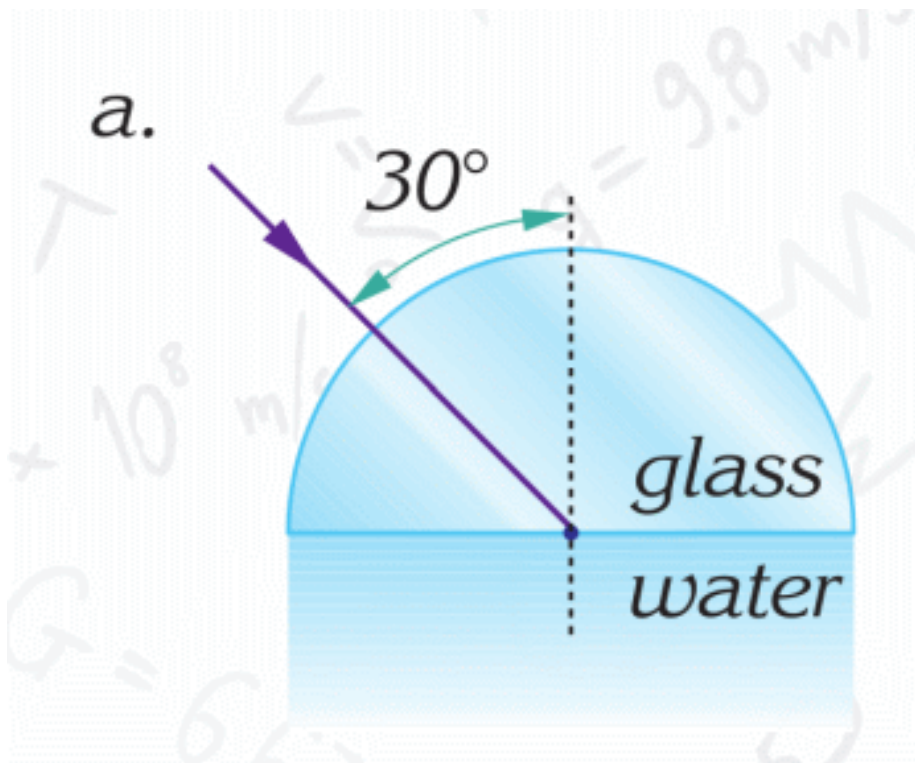

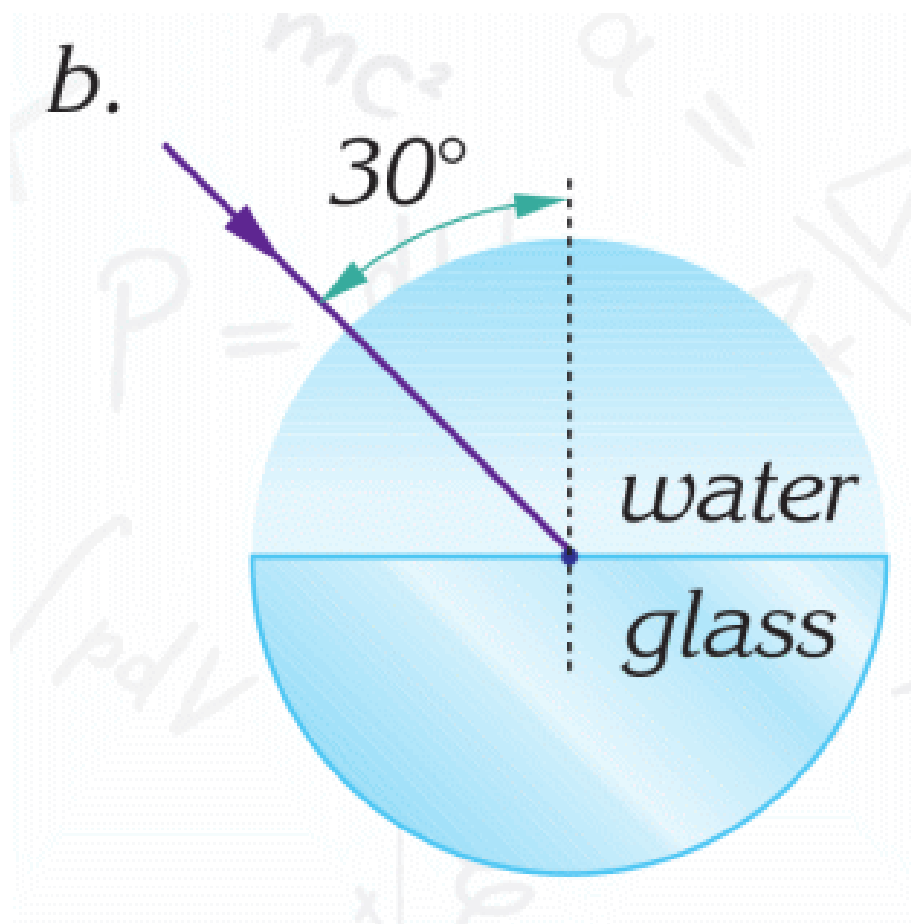

23. Complete the paths of the rays shown in the figures.

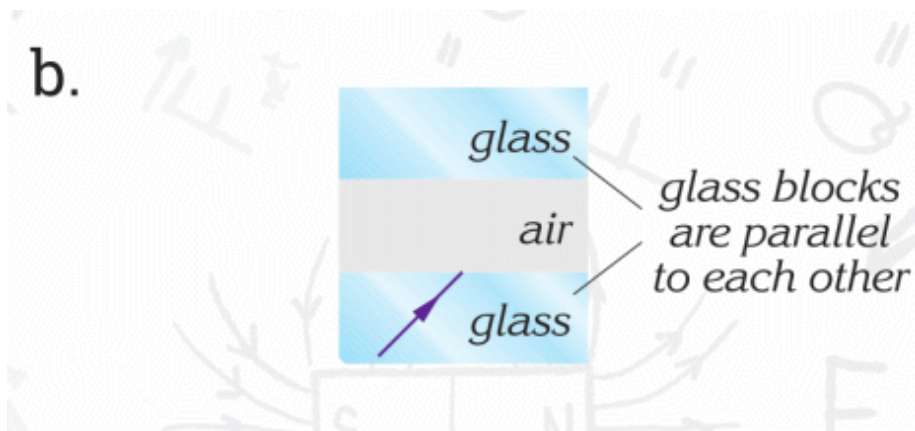
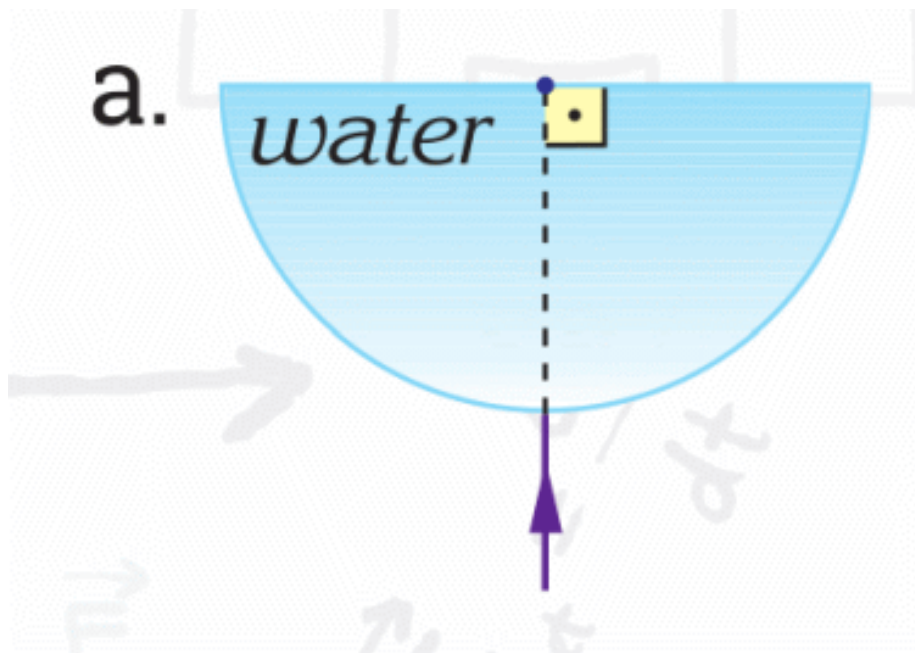

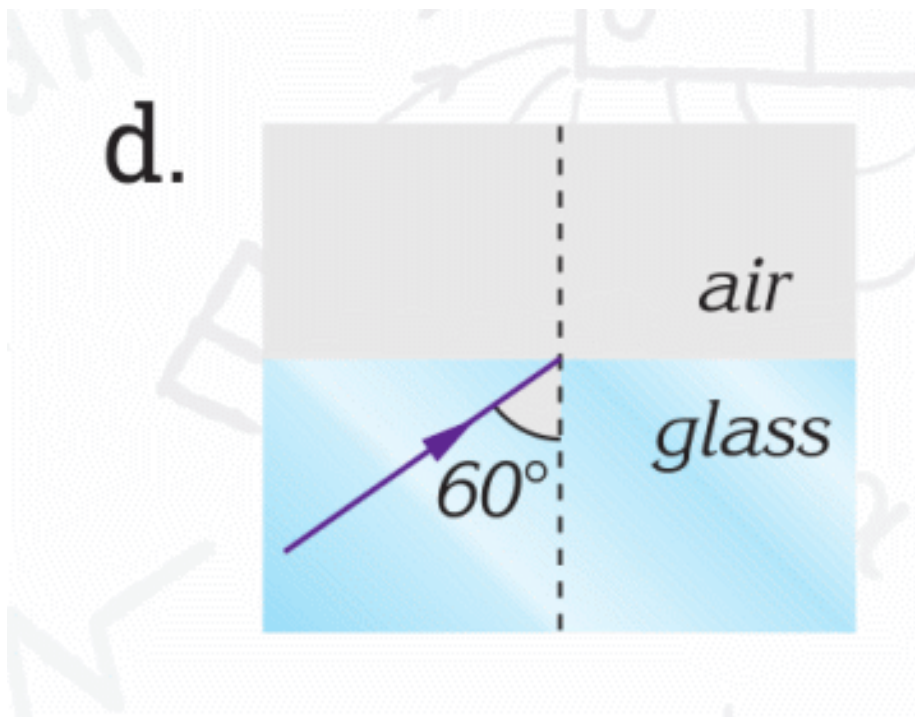
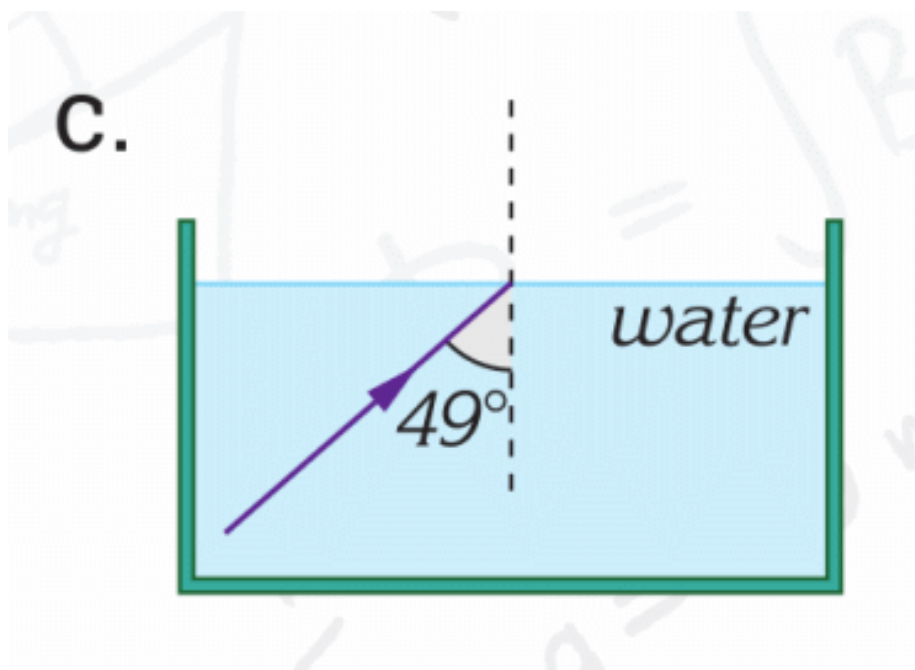

24. An object is 50 cm beyond a convex lens which has a focal length of 20 cm.

a. Where does the image form?

b. List its properties.

c. Where should the object be placed in order to obtain a magnified image?

25. Complete the path of each ray in the following figures.
(Mirror's and lens' principal focuses cross at the same point.)

a.

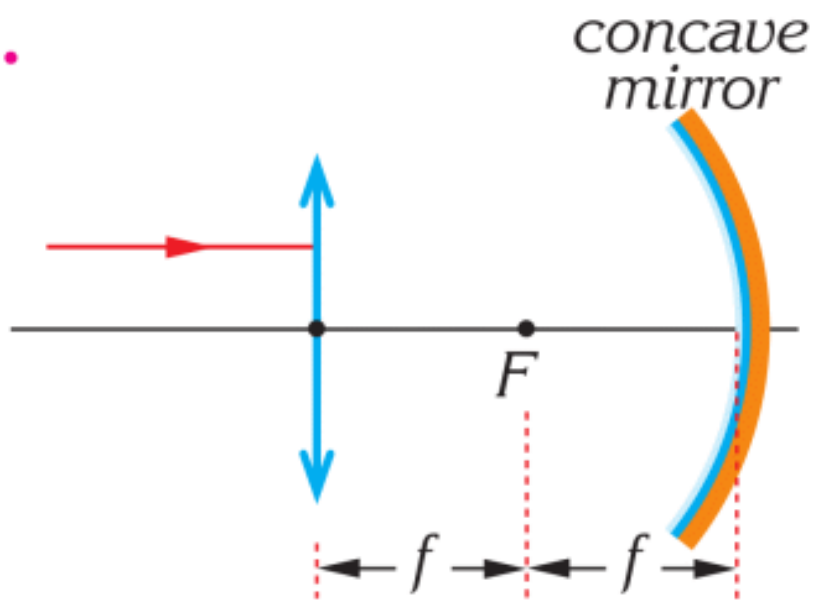

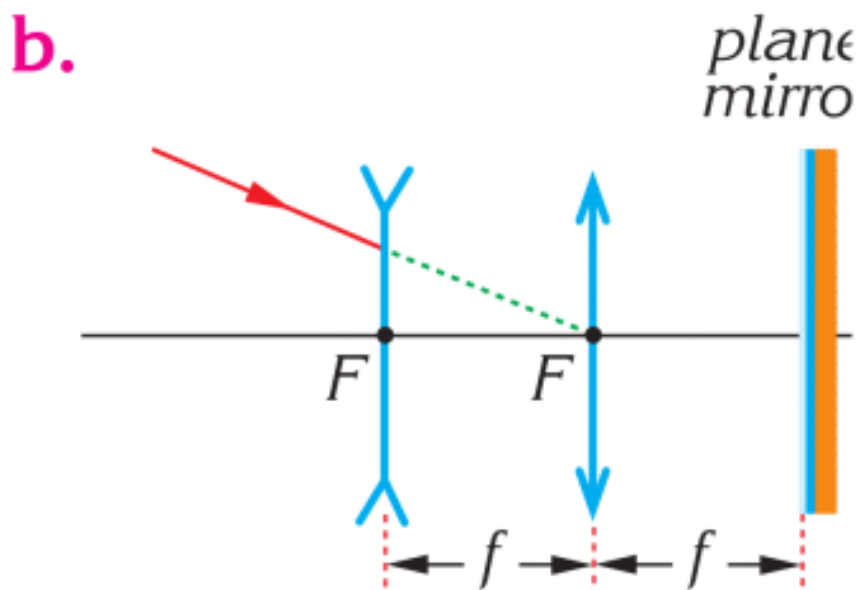

26. The boxes below include only one type of lens; either converging or diverging. Decide which box includes which lens.

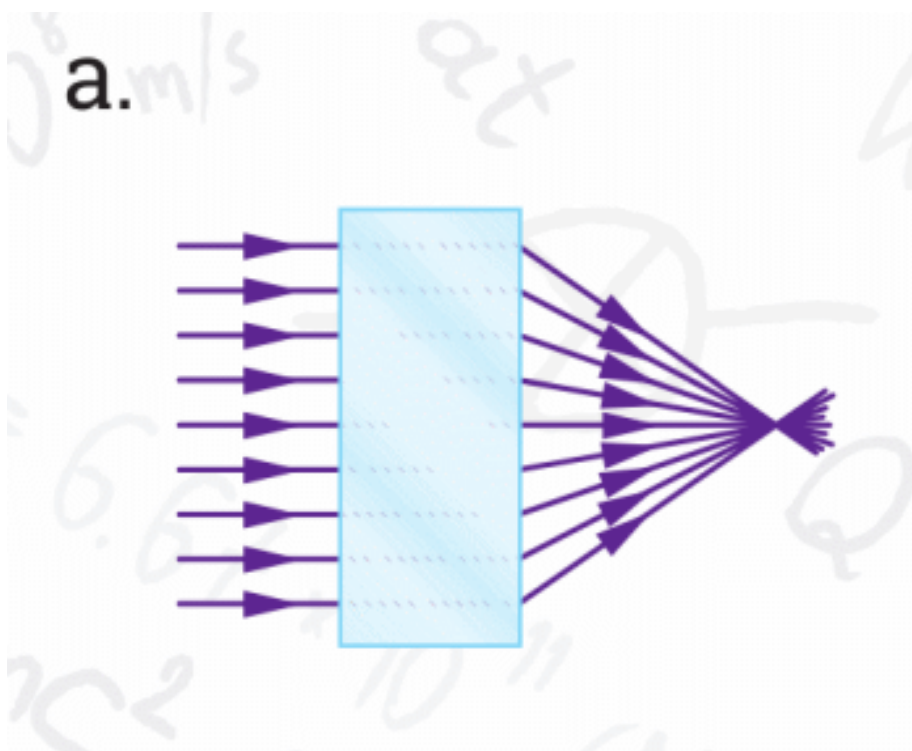

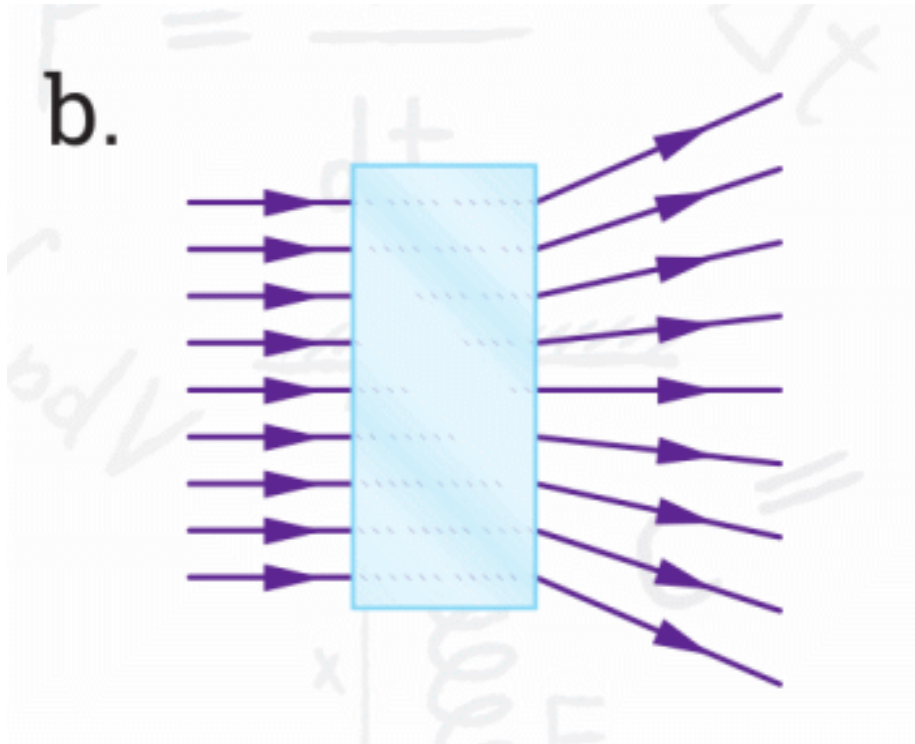

27. Which of the following combination of prisms is similar to a diverging lens?

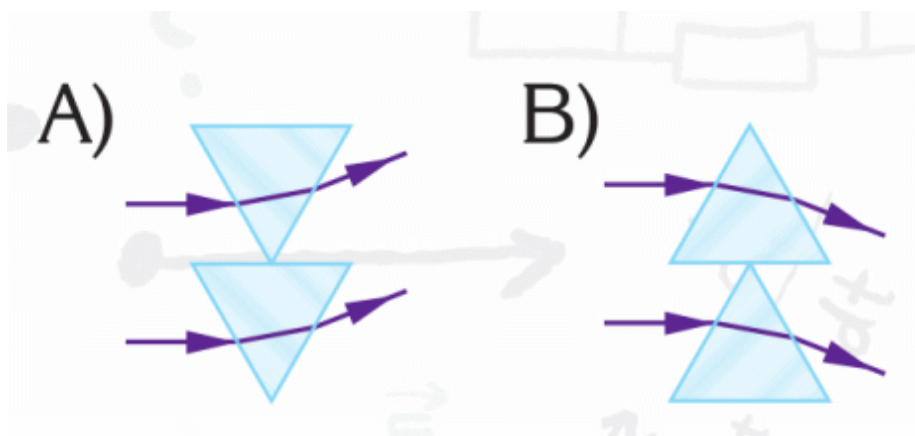

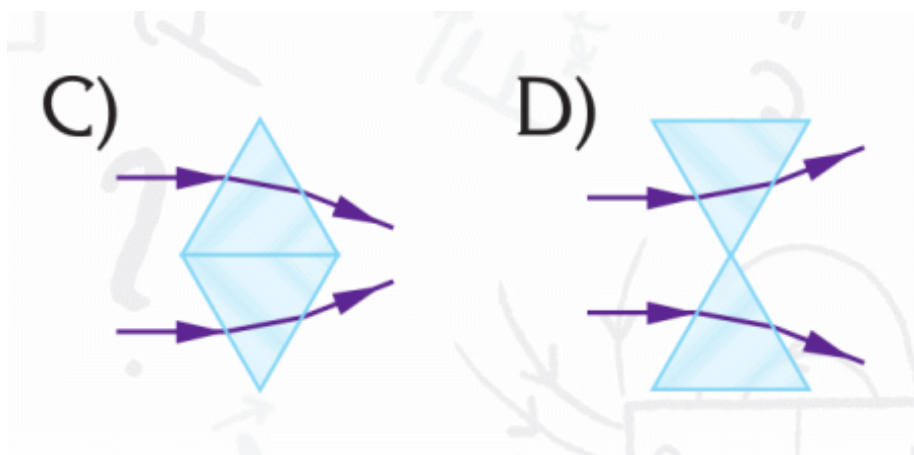

28. In which of the figures below is the path of the ray incorrect?

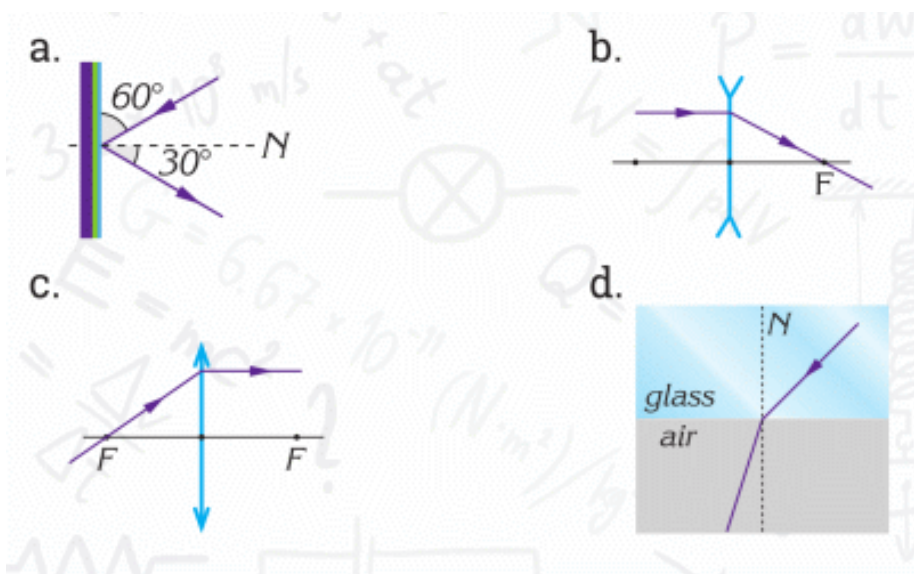

29. Which rays are drawn wrong?

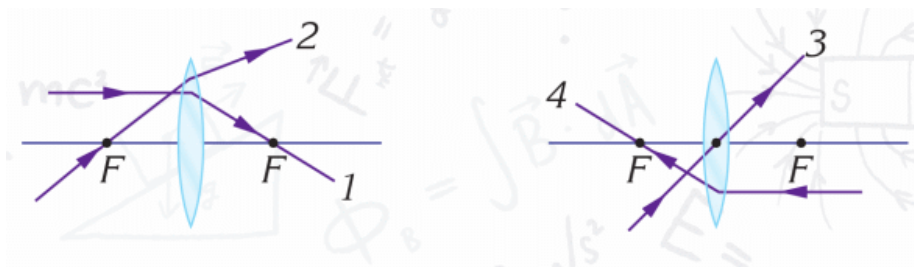

PHYSICS IN LIFE

1. These antennas have concave shape. Why?



2. If Proxima Centauri (star) disappears, we will know about it after 4.2 years. Why?



3. Endoscopes use special materials that can “transport” light. Why?

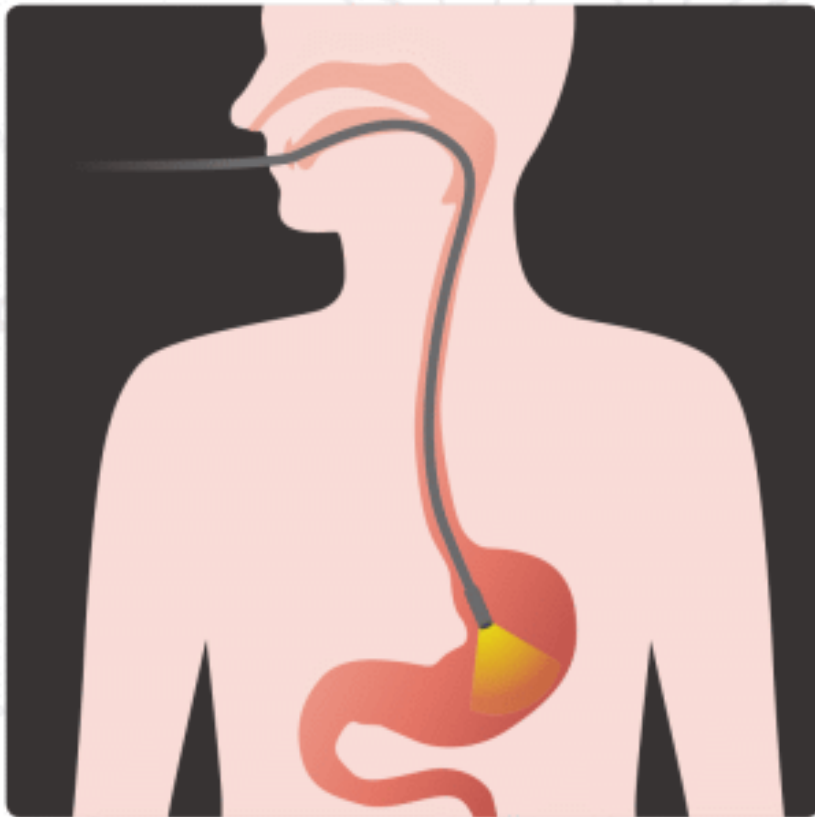

4. Fish is deeper than it looks. Why?



5. Car's dashboard is not smooth. Why?



6. Why do we use such mirrors?



7. We see sunset for several minutes after the Sun disappears. Why?



GLOSSARY

A

Ампер – электр ток күшінің СИ жүйесіндегі өлшем бірлігі.

Абсолюттік нөл – молекулалардың жылулық қозғалыстары түгелдей тоқтаған кезіндегі ең төмен шекті температура.

Абсолюттік температура – Кельвин шкаласы бойынша температура.

Агрегаттық күй – бір заттың әр түрлі күйі.

Алыстан көргіштік – көз жанарының нашарлауы, заттардың түрсіпатының бұлдырап көрінуі (әсіресе, жақыннан).

Амперметр – электр тогының күшін өлшеуге арналған құрал.

Атом – химиялық элементтің қасиеттерін бойына сақтаған оның ең кіші бөлшегі.

Б

Балқу – қатты кристалдық заттың сұйық күйге ауысуы.

Броундық қозғалыс – сұйық не газ ішіндегі ұсақ бөлшектердің қоршаған орта молекулаларының соққысы әсерінен болатын бей-берекет қозғалысы.

Буға айналу – заттың қатты немесе сұйық күйінен газ тәрізді күйге айналу қасиеті.

Булану – заттың сұйық немесе қатты агрегаттық күйден газ тәрізді (бу) күйге ауысу процесі.

В

Ватт – қуат бірліктерінің халықаралық жүйесіндегі (СИ) әмбебап өлшем бірлігі.

Вольт – электр тоғының кернеуін, потенциалдар айырмасын анықтайтын халықаралық өлшем.

Г

Газ – заттың атомдары мен молекулалары бір-бірімен әлсіз байланысы болған заттың күйі.

Генератор – механикалық энергияны электр энергиясына айналдыратын құрал.

Д

Дененің кескіні – нысаннан тарайтын және оның контуры мен жеке бөлшектерін кескіндейтін сәулелердің оптикалық жүйе арқылы өтуі нәтижесінде алынатын кескін.

Джоуль – энергияның өлшем бірлігі.

Диффузия – бір заттың молекулаларының екінші заттың молекулааралық бос орындарына өзара өтуі.

Ж

Жабық жүйе – сыртқы ортадан мейлінше оқшауланған жүйе.

Жақыннан көргіштік – көз кемістігі, мұндайда адам алыстан жөнді көре алмайды.

Жалған кескін – сынған сәулелер қиылыспай, олардың созындылары қиылысқан нүктеде алынады (экранда алу мүмкін емес).

Жану – жылудың реакцияланушы заттар жүйесінде жинақталуына байланысты өздігінен үдеткіш химиялық реакция.

Жану жылуы – кез келген отынның жылу-техникалық құндылығы.

Жартылай өткізгіш – өзінің электрлік қасиеті жағынан өткізгіштер мен диэлектриктердің арасынан орын алатын элементтер.

Жарық – энергияның бір түрі.

Жарық саулесі – жарық энергияның тасымалданатын сызығы

Жарықтың сынуы – оптикалық сәуленің (жарықтың) екі ортаны бөлетін шекарадан өткен кезде таралу бағытының өзгеруі.

Жарықтың шағылуы – жарықтың екі ортаның (1-орта мен 2-ортаның) бөліну шекарасына түскен кезде затпен әсерлесуі нәтижесінде бөліну шекарасынан кері қарай таралуы.

Жинағыш линза – параллель жарық шоғын түйісушіге түрлендіретін оптикалық линза.

Жұқа линза – қалыңдығы үлкен емес линза.

Жылу алмасу – қыздырылған денелер арасында жылу шығару, конвекция, жылу өткізгіштік, т.б. жылу беру түрлері арқылы жылу алмасу.

Жылу оқшаулағыш – қыздырылған денеден қоршаған кеңістікке немесе бір денеден екіншісіне жылудың берілуін азайтатын материал.

Жылу өткізгіштік – дененің температура айырмасы бар нүктелері арасында бір нүктеден екінші нүктеге жылу энергиясын жеткізу қасиеті.

Жылу – жылу алмасуда жүйенің беретін немесе алатын энергиясының мөлшері.

Жылулық қозғалтқыш – жылу энергиясын механикалық жұмысқа түрлендіретін қозғалтқыш.

З

Зат – негізгі физикалық ұғым, массасы мен кеңістікте шектелген пішімі бар бөлшекті нысандардың (атом, молекула, ион, денелер) жиынтығын білдіреді.

І

Ішкі толық шағылу – жарық оптикалық тығыздығы артық ортадан тығыздығы кем ортаға өткенде байқалатын құбылыс.

Ішкі энергия – дененің (жүйенің) тек ішкі күйіне байланысты энергия.

К

Калориметр – әр түрлі процестер кезінде денелерден бөлінетін немесе олардың қабылдайтын жылу мөлшерін өлшейтін аспап.

Калория – жылу мөлшерін есептейтін бірлік.

КилоВатт × сағ – электр энергиясының (жұмыстың) есебін анықтауға арналған өлшем бірлігі.

Компас – жер бетін бағдарлауға, географиялық немесе магниттік меридианның бағытын анықтауға арналған аспап.

Конвекция – сұйық немесе газ бөлшектерінің температурасындағы айырмашылықтар әсерінен туындайтын, сол бөлшектердің жоғары-төмен қозғалуымен сипатталатын ағым.

Конденсатор – жұқа диэлектрик қабатымен бөлінген екі өткізгіштен тұратын жүйе.

Конденсация – газдың немесе будың сұйық түрге айналуы.

Коррозия – химиялық үрдіс зардабынан металдардың мұжылуы.

Көлем – геометриялық денелердің кеңістіктен алатын бөлігін сипаттайтын шамасы.

Кулон – бірліктердің халықаралық жүйесіндегі электр мөлшерінің бірлігі.

Қ

Қайнау – сұйықтықтың тұтас көлемінде бу көпіршіктерінің пайда болып, олардың сұйық бетіне шығып буға айналуы.

Қайнау температурасы – сұйық күйден буға фазалық өту кезіндегі сұйықтың температурасы.

Қайтымсыздық – денелердің бұрынғы калпына қайта орала алмауы.

Қаныққан бу – заттың буы өзінің сұйық немесе қатты күйімен жылжымалы тепе-теңдікте болатын күйі.

Қатаю – сұйық балқыманың қалыпқа құйғанда кристалданып, қатаю процесі.

Қоспа – бірнеше жай немесе күрделі заттардан құралатын жүйе.

Қыздыру – денеге жылу берілгенде оның температурасын арттыру.

Л

Линзаның үлкейтуі – кескіннен линзаға дейінгі қашықтықтың және линзадан денеге дейінгі қашықтықтардың қатынасы.

М

Магнит – магниттелушілік қасиеті бар, яғни магнит өрісін туғызатын дене.

Магнит өрісі – қозғалыстағы электр зарядтары мен магниттік моменті бар денелерге әсер ететін күштік өріс.

Меншікті балқу жалуы – қатты дененің бірлік массасын балқу температурасында сұйыққа айналдыруға қажетті жылу.

Меншікті булану жылуы – сұйықтың бірлік массасын қайнау температурасында буға айналдыруға қажетті жылу.

Меншікті жылу сыйымдылығы – 1 кг дененің температурасын 1°С-ге жоғарылату үшін берілетін жылу мөлшері.

Меншікті кедергісі – заттың түріне байланысты кедергінің көрсеткіші.

Молекула – заттың химиялық қасиеттерін бойына сақтаған оның ең кіші бөлшегі.

Мөлдір – жарықты өткізетін дене.

Мөлдір емес дене – жарықты өткізбейтін дене.

О

Оптикалық ось – жарық сәулесінің қосарланып сынуына ұшырамай тарала алатын бағыт.

Отын – жылу энергиясын алуға қолданылатын жанғыш заттар.

Ө

Өткізгіш – электрлік энергияны тасымалдау үшін қолданылатын және бір түрде орналастырылған металл немесе кез келген өткізгіш сым.

П

Пайдалы әсері коэффициенті (ПӘК) – пайдалы қуаттың келтірілген қуатқа қатынасы.

Потенциал айырымы – электр заряды бір нүктеден екінші нүктеге орын ауыстырғанда электр өрісі күшінің атқаратын жұмысының сол зарядтың шамасына қатынасы.

Призма – табандары параллель жазықтықтарда жататын тең көпбұрыштардан тұратын, бүйір қырлары табандарына перпендикуляр кеңістік дене.

Р

Радиация – жылулық сәуле шығаруы.

Резистор – электр тізбегінің әртүрлі тармақтарындағы ток күшін, не кернеуді шектеу немесе реттеу үшін қолданылатын бұйым.

Реостат – электр желісіндегі кернеуді немесе токты тежейтін және реттейтін электр құрылғысы.

С

Сақтандырғыш – электр тізбектерін ток күшінің рұқсат етілген мөлшерден асып кетуінен қорғауға арналған тетік.

Сұйықтық – сұйық агрегаттық күйдегі зат.

Сығылу – дене көлемінің кішіреуі.

Сылқандау – денеден жылу мөлшері алынып оның температурасын тусіру.

Сыну бұрышы – сынған толқынның таралу бағыты мен толқынның сынуы өтетін екі орта бөлігінің бетіне перпендикуляр арасындағы бұрыш.

Т

Тарту – заттардың бір-біріне әсерлесуінің түрі.

Тебілу – заттардың бір-біріне әсерлесуінің түрі.

Телескоп – аспан шырақтарын электр-магниттік сәуле арқылы бақылауға арналған астрономиялық құрал.

Температура – макроскопикалық жүйенің термодинамикалық тепе-теңдік күйін сипаттайтын физикалық шама.

Температура шкаласы – температураның әр түрлі мәндеріне сәйкес келетін цифрлар тізбегінің жүйесі.

Термос – бұл жылу өткізбейтін немесе сақтайтын күнделікті өмірде қолданылатын ыдыс-аяқтың бір түрі.

Түсу бұрышы – түсуші толқынның таралу бағыты мен толқын түсетін екі орта бөлігінің бетіне перпендикуляр арасындағы бұрыш.

Тұйық тізбек – тұйықталған электр тізбегінде үздіксіз зарядтар қозғалысы бола болады.

Тұрақты ток – ток күшінің шамасы мен бағыты уақытқа байланысты өзгермейтін электр тогы.

Ұ

Ұлғаю – дененің өлшемінің артуы.

Ф

Фокальдік жазықтық – жүйенің тоғысы орналасқан оське перпендикуляр идеал оптикалық жүйенің жазықтығы.

Фокус – шағылып және сынып өтетін жарық сәулелері жиналатын нүкте.

Ш

Шағылу бұрышы – нормаль мен шағылған сәуле арасындағы бұрыш.

Шашыратқыш линза – жарықтың параллель шоғын таралған шоққа түрлендіретін оптикалық линза.

Шын кескін – сынған сәулелер бір нүктеде қиылысқанда пайда болады (экранда).

Ы

Ылғалдылық – қатты денедегі, ұнтақ заттағы, газдағы ылғал мөлшері.

Э

Эквиваленттік кедергі – бірнеше кедергіден тұратын тізбектің жалпы кедергісі.

Электр ажыратқыш – қорек көзін жандырып, сөндіретін тетік.

Электр заряды – бөлшектер мен денелердің сыртқы электромагниттік өріспен өзара әсерін сипаттамалардың бірі.

Электр кернеуі – электр заряды бір нүктеден екінші нүктеге орын ауыстырғанда электр өрісі күшінің атқаратын жұмысының сол зарядтың шамасына қатынасы.

Электр қозғаушы күш – электр тізбегіне жалғанған, табиғаты электростатикалық емес энергия көзі.

Электр қуаты – электр элементтегі тоқ күші мен кернеудің көбейту нәтижесі.

Электр потенциалы – электростатикалық өрісті энергетикалық сипаттайтын скаляр шама. Ол өріс зарядының потенциалдық энергиясының осы зарядқа қатынасына тең.

Электр санағыш – жумсалған электр энергиясын өлшейтін құрал.

Электр станциясы – электр энергиясын шығаратын индустриялық жер.

Электр сызбасы – электр тізбегінің суреті.

Электр тізбегі – электр тогын өткізетін құрылғылардың жиынтығы.

Электр тогы – электр қозғаушы күштің әсерінен зарядтардың (зарядталған бөлшектер немесе дене) бағытталған қозғалысы.

Электрмагнит – электр тогы жүргенде магнит өрісі пайда болатын жасанды магнит.

Электромагниттік толқындар – байланыс тізбегін құрайтын екі сымның арасындағы электрлік және

магниттік өрістер бір-бірімен белгілі бір электромагниттік энергия мөлшерінде байланыста болатын толқын.

Элементар заряд – барлық оң және теріс электр зарядтарының ішінде абсолют мәні жағынан ең кіші болатын электр заряды.

Энергия – материя қозғалысының әртүрлі формасының жалпы өлшеуіші.

ANSWERS

Page 25 topic 1

1.A 2.C 3.A 4 False, they vibrate

Page 25 topic 2

1. A 2. B 3. B 4. True 5. A 6. A 7. B 8. B 9. A 10. B

Page 27 Test-1

1.B 2.D 3.C 4.A 5.C 6.D

Page 27 Test-2

1.C 2.D 3.A 4.B 5.D

Page 42 Test-1

1.A 2.B 3.A 4.D 5.B 6.D 7.C 8.B 9.C 10.D II.A

Page 43 Test-2

1.B 2.C 3.C 4.D 5.A 6.B 7.C 8.B 9.D

Page 57

1.C 2.D

Page 77

1.B 2.A 3.D 4.C 5.B 6.A

Page 107

4. B 6. A

Page 123

3. C, D 4. A 5. C

Page 153

27. D 28. C 29. 2

PROBLEMS

Page 75

9) - 0 + 10) + - 0 11) + 12) I. Open more II. Collapse 13) 7.2×10^4 N
14) $5\sqrt{10}$ m 15) 7.2×10^{-4} N 16) 9 time decrease 7.2×10^4 17) 5.4×10^6 N 18) -810 nC
19) 5.4×10^4 V, 13.5×10^5 V 20) $9 \cdot 10^4$ V 21) $2 \cdot 10^{10}$ V 22) 0.16 J 23) a) doubled b) tripled c) halved
24) 8 pC 25) 88.5 pF 26) 0.88 mm 190.88 mm 27) 132.7 nC

Page 107

1) 225 Ω 2) $I_1=6$ A, $I_2=2$ A, $I=8$ A 3) 13 Ω 4) B 5) 1.9 A 6) A 7) 5.45 A, 9.09 A, 3.27 A
8) $I=6$ A $V=240$ V 9) 6 W

REFERENCES

1. Physics and Astronomy Grade 8, Mehmet Surmen, Астана кітап publishing, Алматы 2016, 279 pages.
2. Modular system First step to Physics Volume 2, Semih Aydin, Zambak publishing, Izmir 2009, 154 pages.
3. Modular system Thermodynamics and Molecular physics, Osman Ozpala, Ahmet Ajet, Zambak publishing, Izmir 2008, 152 pages.
4. Modular system Electricity and Magnetism, Irfan Polat, Omar Ilhan, Zambak publishing, Izmir 2010, 192 pages.
5. Physics for Scientists and Engineers, Serway Jewett, Thomson Brooks publishing, United State of America 2004, 1382 pages.
6. Physics, Raymond A. Serway, Jerry S. Faughn, Holt, Rinehart and Winston publishing 2006, 992 pages.
7. Conceptual Physics, Paul G. Hewitt, Addison-Wesley publishing, United State of America 2006, 811 pages.



PHYSICS

Grade 8

Authors:

Altynbek Karabatyrov
Aibek Baieshov
Yesbol Duisseyev
Nursultan Shokobalinov
Nurtybek Tashev

Edited by:

Aidyn Tussyubzhanov

Designed by:

Darkhan Berdibayev